

Line

110 1/8" - ø4

AIRCOMP

Elettropiloti
Solenoid valves



Dati tecnici - Technical data

Fluido - Fluid	Aria filtrata con o senza lubrificazione - Filtered air with or without lubrication
Temperatura d'esercizio - Working temperature	-5+50°C (23+122°F)
Pressione d'esercizio - Working pressure	vuoto/vacuum ±10 Bar/1,00 MPa
Lubrificazione - Lubrication	non necessaria - not necessary
Tipo di azionamento manuale - Manual override type	bistabile - bistable
Portata di riferimento - Reference flow rate	55 NI/min (P=6 Bar - Δp=1 Bar)
Materiali - Materials	PBT, acciaio inox, ottone, NBR, POM, FPM PBT, stainless steel, brass, NBR, POM, FPM
Peso - Weight	0,08 Kg

Guida alle referenze Guide to references

EP110 1/8 3 NC SN OO C

Prodotto
Product
EP110 = Elettropilota serie 110
Line 110 solenoid valve

Connessione
Connection
1/8 = G1/8"
AU4 = Raccordi automatici ø4mm
ø4mm Push-in fittings

Funzione
Function
3 = 3/2
2 = 2/2

Tipo
Type
NC = Normalmente chiuso
Normally closed
NO = Normalmente aperto
Normally opened

Comando
Actuation
C = Con comando manuale
With manual override
N = Senza comando manuale
Without manual override

Alimentazione
Inlet side
SX = Sinistro
Left
DX = Destro
Right
OO = Sinistro e destro
Left and right

Configurazione
Configuration
SN = Elettropilota singolo
Single solenoid
MI = Modulo intermedio
Intermediate unit
ME = Modulo di entrata
Inlet unit
MU = Modulo in uscita
Outlet unit

L'elettropilota Aircomp Serie 110 è stato concepito per offrire la massima versatilità d'impiego e soddisfare quindi le molteplici esigenze applicative richieste dal mercato. Le batterie di EP modulari possono essere composte di elettropiloti 3/2, sia normalmente chiusi (NC) che normalmente aperti (NO), con l'indubbio vantaggio di concentrare tutte le funzioni in un unico gruppo valvole.

Lo scarico convogliato dell'elettropilota inoltre, evita i problemi legati all'immissione nell'ambiente di aria carica d'impurità e condensa, così dannose per i componenti elettrici che talvolta sono inevitabilmente montati accanto alle valvole.

Le batterie infine, possono essere fissate grazie ai fori predisposti sul corpo di ogni elettropilota, oppure attraverso un'apposita staffa che permette l'aggancio ad una barra "omega" DIN EN50022 35mm.

Aircomp Solenoid Valve Line 110 has been designed in order to offer the greatest versatility in use and thus, satisfy the several application requirements that market demands. The battery assembly of modular Solenoid Valves can consist of Solenoid Valves 3/2 both normally closed (NC) and normally open (NO), providing the undoubted advantage of concentrating all functions in one single valve battery.

Moreover, the common exhaust of this Solenoid Valve avoids problems relating to the emission into the environment of air charged with impurity and condensate, then affecting deeply the electric components that are necessarily mounted near the valves.

The batteries can be mounted through the preset holes on the body of each Solenoid Valve, or through a proper bracket enabling the coupling to an omega rail DIN EN50022 35 mm.

Elettropilota Singolo Single Solenoid valve



Elettropilota singolo Single solenoid valve

FISSAGGIO: con viti 3x30; oppure su barra omega DIN EN50022 (35mm) con l'ausilio del kit di staffaggio, venduto separatamente (pag.6).

FIXING: with screws 3x30; or to rail DIN EN50022 (35mm) by means of a mounting kit, that is separately supplied (see page 6).

CORPO: disponibile in tre versioni;
1) **SX** - con inserti G1/8" sul lato sinistro
2) **DX** - con inserti G1/8" sul lato destro
3) **OO** - con inserti G1/8" su entrambe i lati

BODY: available in three versions;
1) **SX** - with inserts on left side
2) **DX** - with inserts on right side
3) **OO** - with inserts on both sides

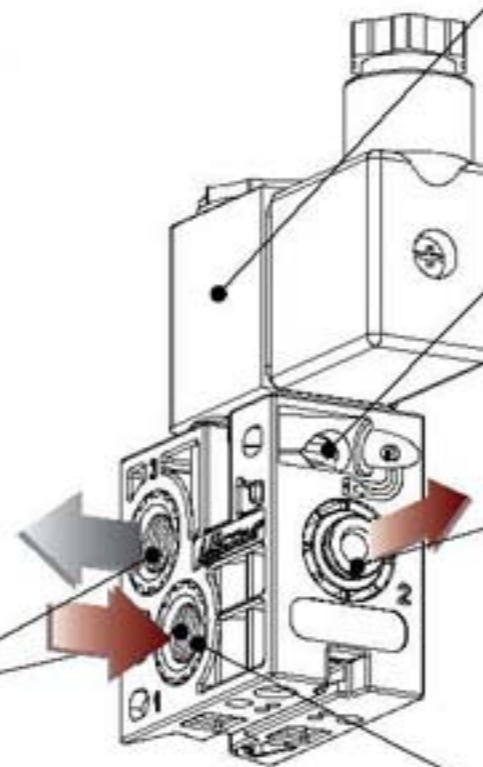
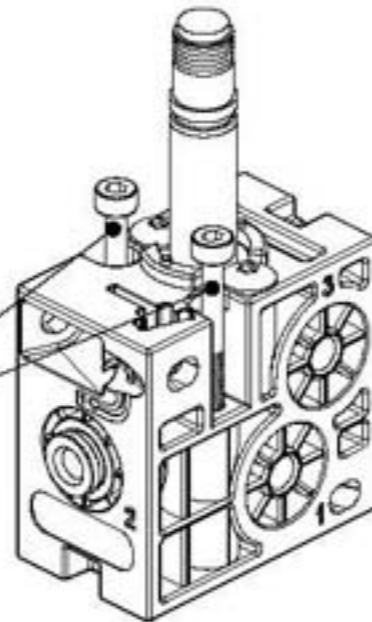

BOBINE: disponibili in diversi voltaggi (pagina 6);
AC 24V, 110V, 220V
DC 12V, 24V

COILS: Available in different voltages (see page 6):
AC 24V, 110V, 220V
DC 12V, 24V

AZIONAMENTO MANUALE: bistabile.
MANUAL ACTUATION: bistable.

CONNESSIONE D'UTILIZZO: disponibile in due versioni;
1) **AU4** - raccordi automatici ø4mm
2) **1/8 - G1/8"**

OUTLET PORT: available in two versions:
1) **AU4** - push-in fittings ø4mm
2) **1/8 - G1/8"**

COPPIA DI SERRAGGIO MASSIMA:
1÷1,2 N·m.

MAX. TORQUE: 1÷1,2 N·m.

Codici di ordinazione Order codes

Elettropilota singolo - Single solenoid valve

DESCRIPTION	CODE	REF.
	1103023001	EP110 1/8 3 NC SN SX C
	1103023002	EP110 1/8 3 NC SN DX C
	1103023003	EP110 1/8 3 NC SN OO C
	1103023004	EP110 1/8 3 NO SN SX C
	1103023005	EP110 1/8 3 NO SN DX C
	1103023006	EP110 1/8 3 NO SN OO C
	1103093001	EP110 AU4 3 NC SN SX C
	1103093002	EP110 AU4 3 NC SN DX C
	1103093003	EP110 AU4 3 NC SN OO C
	1103093004	EP110 AU4 3 NO SN SX C
	1103093005	EP110 AU4 3 NO SN DX C
	1103093006	EP110 AU4 3 NO SN OO C

Versioni disponibili Available versions

VERSIONE "SX" "SX" VERSION

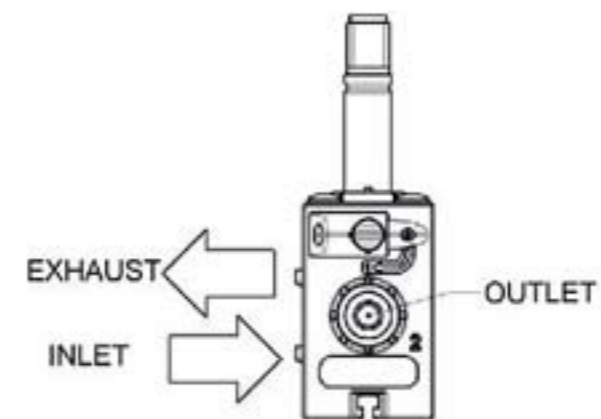

VERSIONE "DX" "DX" VERSION

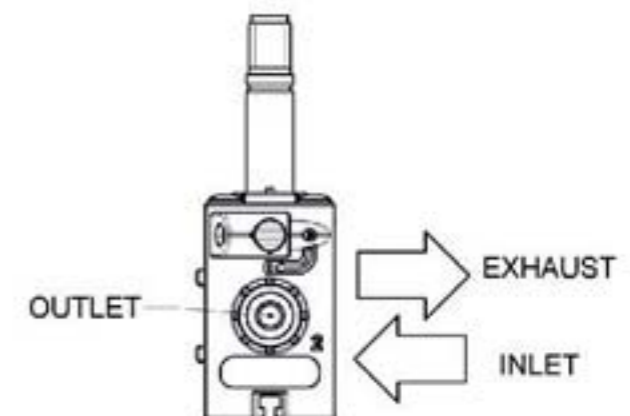

VERSIONE "OO" "OO" VERSION

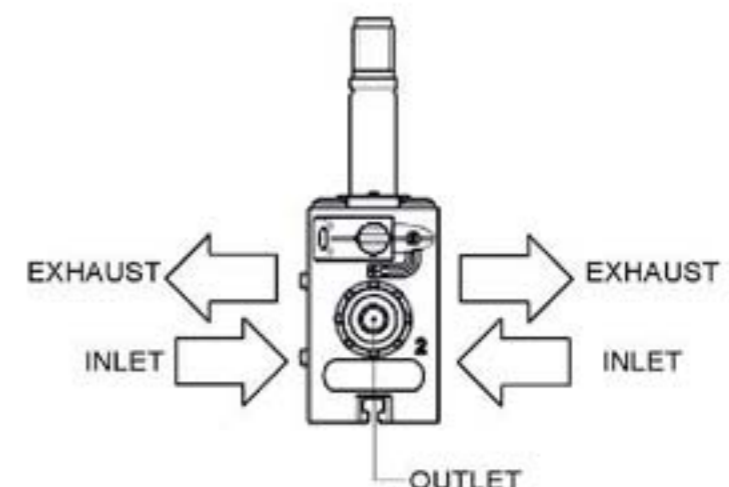

Dimensioni Dimensions

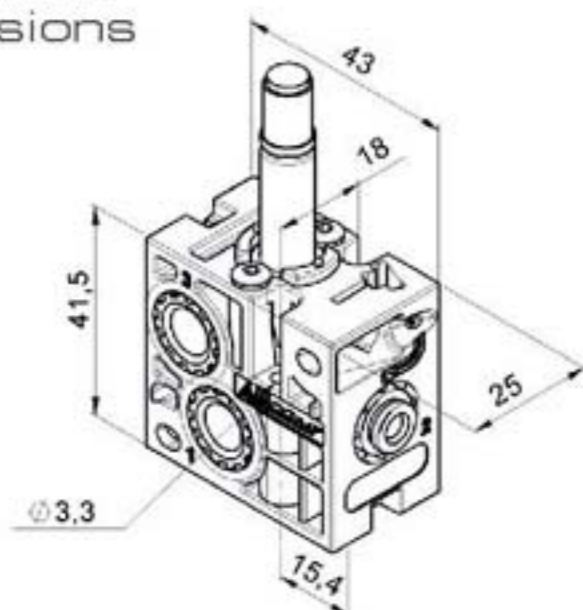

Elettropiloti modulari
Modular solenoid valves

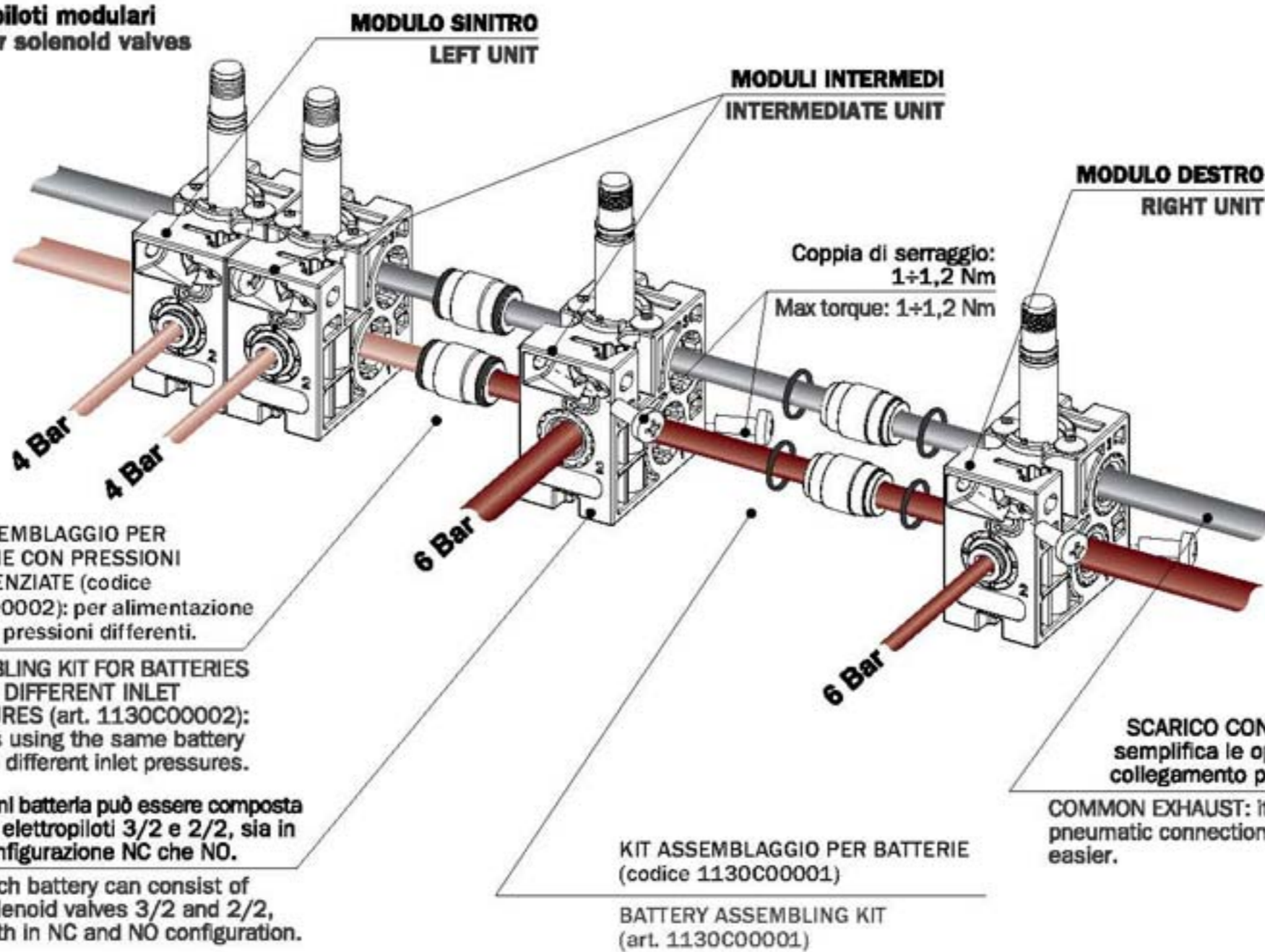

KIT ASSEMBLAGGIO PER BATTERIE CON PRESSIONI DIFFERENZIALI (codice 1130C00002): per alimentazione con due pressioni differenti.

ASSEMBLING KIT FOR BATTERIES HAVING DIFFERENT INLET PRESSURES (art. 1130C00002): it allows using the same battery with two different inlet pressures.

Ogni batteria può essere composta da elettropiloti 3/2 e 2/2, sia in configurazione NC che NO.

Each battery can consist of solenoid valves 3/2 and 2/2, both in NC and NO configuration.

KIT ASSEMBLAGGIO PER BATTERIE (codice 1130C00001)

BATTERY ASSEMBLING KIT (art. 1130C00001)

SCARICO CONVOGLIATO: semplifica le operazioni di collegamento pneumatico.

COMMON EXHAUST: it makes the pneumatic connection operations easier.

Elettropiloti per montaggio in batteria - Solenoid valves for battery assembly

① MODULO SINISTRO - LEFT UNIT versioni disponibili - available types

EP110 _ _ _ ME SX _

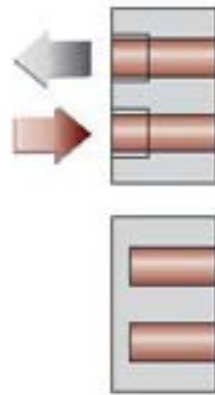

EP110 _ _ _ MU SX _



② MODULO INTERMEDIO - INTERMEDIATE UNIT



EP110 _ _ _ MI OO _



③ MODULO DESTRO - RIGHT UNIT versioni disponibili - available types

EP110 _ _ _ ME DX _

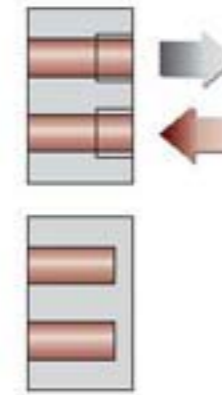

EP110 _ _ _ MU DX _

① MODULO SINISTRO - LEFT UNIT

② MODULO INTERMEDIO - INTERMEDIATE UNIT

③ MODULO DESTRO - RIGHT UNIT

DESCRIPTION	CODE	REF.	CODE	REF.	CODE	REF.
 3/2 NC ø1/8"	1103023009	EP110 1/8 3 NC ME SX C	1103023007	EP110 1/8 3 NC MI OO C	1103023011	EP110 1/8 3 NC ME DX C
	1103023013	EP110 1/8 3 NC MU SX C			1103023015	EP110 1/8 3 NC MU DX C
 3/2 NO ø1/8"	1103023010	EP110 1/8 3 NO ME SX C	1103023008	EP110 1/8 3 NO MI OO C	1103023012	EP110 1/8 3 NO ME DX C
	1103023014	EP110 1/8 3 NO MU SX C			1103023018	EP110 1/8 3 NO MU DX C
 3/2 NC AU4	1103093009	EP110 AU4 3 NC ME SX C	1103093007	EP110 AU4 3 NC MI OO C	1103093011	EP110 AU4 3 NC ME DX C
	1103093013	EP110 AU4 3 NC MU SX C			1103093015	EP110 AU4 3 NC MU DX C
 3/2 NO AU4	1103093010	EP110 AU4 3 NO ME SX C	1103093008	EP110 AU4 3 NO MI OO C	1103093012	EP110 AU4 3 NO ME DX C
	1103093014	EP110 AU4 3 NO MU SX C			1103093018	EP110 AU4 3 NO MU DX C
 1130C00001	1130C00001	Kit assemblaggio batterie Battery assembling kit				
	1130C00002	Kit assemblaggio batterie (pressioni differenziate) Battery assembling kit (different pressures)				

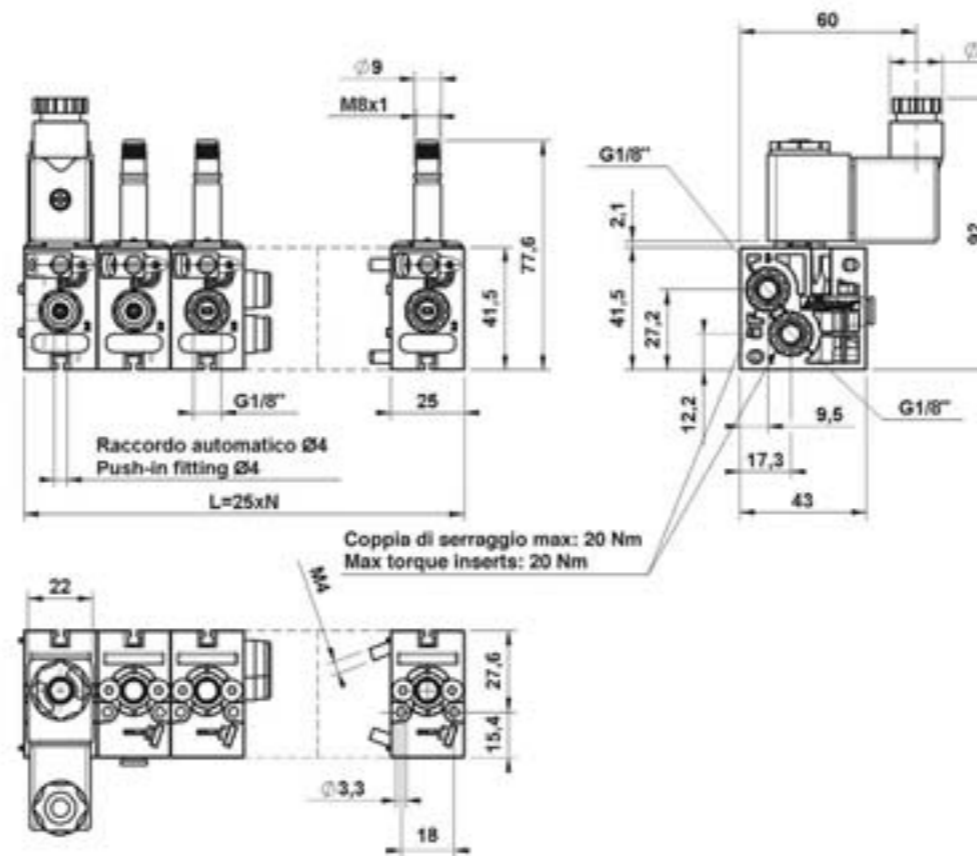

Kit staffaggio su barra DIN EN50022 (35mm) Mounting kit for rail DIN EN50022 (35mm)



CODICE-CODE	REF.
1130C0003	Kit di fissaggio su barra DIN Mounting kit for DIN rail

Barra DIN EN50022 (35mm)
DIN EN50022 rail (35mm).

Kit di fissaggio su barra DIN: utile per il fissaggio su barra DIN, di elettropiloti in configurazione singola o in batterie.
DIN rail mounting kit: it is useful for mounting solenoid valves, either in single or battery configuration, on DIN rail.

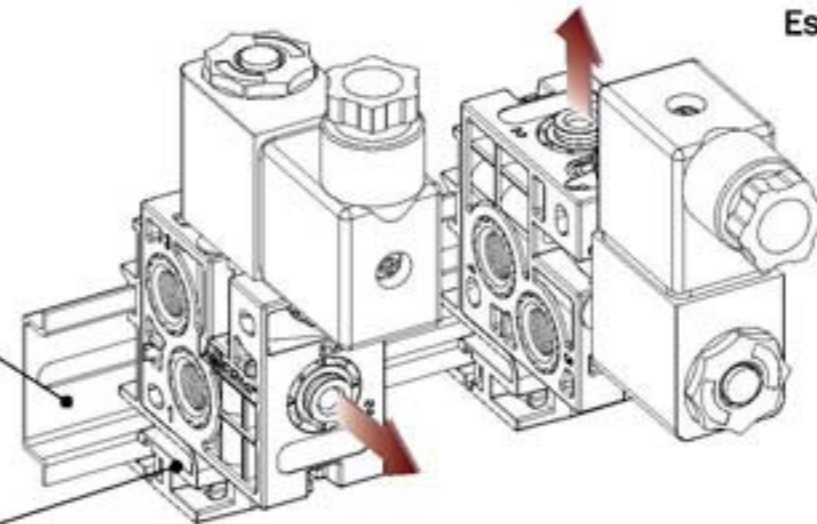

Esempi di montaggio
Mounting example

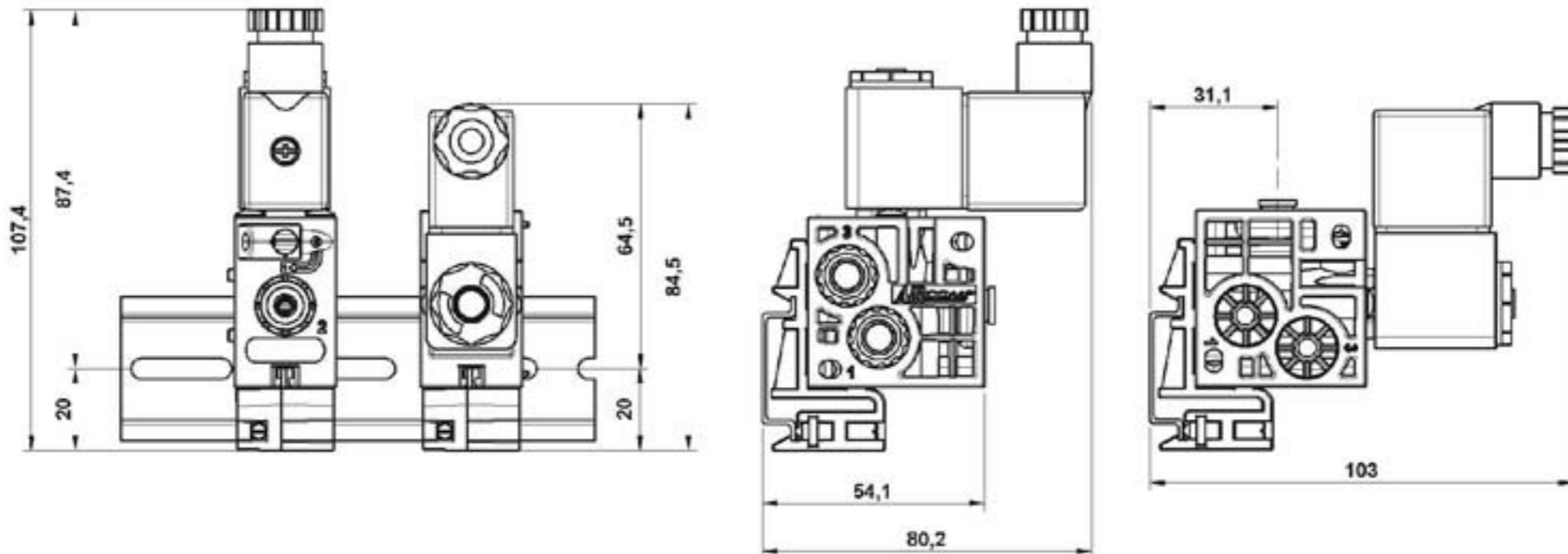

Ghiera fissaggio bobina Coil fixing unit



CODE	REF.
1311A00015	Ghiera di fissaggio aperta Open fixing nut

Bobina 22mm 22mm Coil

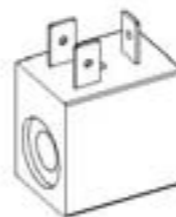

CODE	REF.
A502600018	BOBINA (COIL) DC12V
A502600006	BOBINA (COIL) DC24V
A502600007	BOBINA (COIL) AC24V 50/60HZ
A502600008	BOBINA (COIL) AC110V 50/60HZ
A502600009	BOBINA (COIL) AC220V 50/60HZ

Connettore Connector

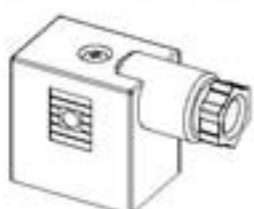

CODE	REF.
A502600010	CONNECTOR SP. 22 mm

PER CONNETTORI LUMINOSI E PRECABLATI, VEDERE PAG. 96
FOR LED CONNECTORS AND PRE-CABLED, PLEASE SEE PAGE 96