



ŽELEZIARNE<sup>®</sup>  
PODBREZOVÁ



**USER'S**  
**HANDBOOK**  
STEEL TUBE & PIPE ■

13<sup>TH</sup> EDITION, MARCH 2016



## Dear business partners, ladies and gentlemen

this technical manual we prepared to contribute to the further development of our mutually good business relationships. The guide contains technical specifications for steel tubes and tubular semi-finished products produced in group companies of Železiarne Podbrezová Group. Technical details are the content of national or transnational standards and regulations, or even bilateral technical and delivery regulations or specifications. Products made out of tubes must at the same time meet the requirements of relevant laws and regulations relating to health, safety and the environment during its use. For this reason, the manual also gives a brief overview of standardization.

### Important warning:

In the countries of European Union the European standards (EN) were implemented (taken) into the system of national standards. The original standards are already invalid. Therefore, in business the original standards of individual countries should not be used anymore, but valid EN standards. Data from the original standards mentioned in overviews serve during the transitional period for the possibility of comparing individual parameters in the study of older technical documentation when examining the possibility of substituting the tubes supplied and under the original standards. GOST standards, U.S. standards (ASTM, ASME, ANSI, API) and JIS remain valid.

## Content

Standardization companies and standards .....	3
Steel tubes - classification, terms and definitions .....	3
Technical standards for steel tubes .....	3
Overview of the main characteristics of steel tubes .....	4
Tube dimensions .....	4
Ovality, eccentricity .....	4
Tube weight .....	4
Steel for tubes .....	5
Technical delivery conditions (TDC) for tubes .....	7
Tube testing .....	7
Quality management systems, certification, legislation .....	9
Management of quality .....	9
The legislation .....	9
Tubes for construction use .....	9
Tubes for pressure purposes .....	9
Tubes for mechanical application and machine parts .....	9
Flow diagram of the production in a joint stock company Železiarne Podbrezová .....	10
Production program - breakdown of the products according to usage .....	12
Overview of the TDC for tube groups by usage .....	13
Product Part .....	14
Seamless structural hollow section.....	14
Seamless steel tubes for mechanical and general engineering purposes .....	16
Seamless steel tubes for pressure equipment for room temperature .....	22
Seamless boiler tubes for pressure equipments (high temperature) .....	26
Seamless steel tubes for pressure purposes of fine-grained steels .....	34
Seamless boiler tubes for pressure equipments (low temperature) .....	36
Steel heat exchanger tubes .....	48
Tubes with internal ribs .....	52
Seamless steel tubes for welding and threading .....	54
Seamless steel tubes for pipelines for combustible fluids .....	56
Casing and Tubing .....	60
Standard precision seamless steel tubes, cold drawn .....	62
Tubes for the automotive industry .....	73
Injection tubes .....	74
Tubes, galvanized with PVC coating .....	74
Special tubular sections .....	74
Tubes for hydraulic and pneumatic cylinders - HPZ .....	75
Tubes for hydraulic and pneumatic cylinders – tubes ready to use - HP .....	77
Tubes for hydraulic and pneumatic circuits and galvanized tubes - HPL .....	79
Tubes for bearings production .....	88
Tubes in coils .....	89
Cut and bent tubes .....	90
Butt – welding steel elbows .....	92
Butt – welding steel reducers .....	99
Continuously cast steel blooms .....	100
<b>Attachments:</b>	
Tube packaging .....	101
Tests for mechanical and technological properties of tubes .....	102
The tightness of tubes under the ASTM (ASME) regulations .....	104
Definition of status and nomenclature of heat treatment .....	104
Steel designation according to EN 10 216 standards .....	105
Conversion table of steel parameters .....	106
Indicative comparison of steel .....	107
Comparison of tensile strength and hardness .....	118
Designation system for steel: EN 10027 - 2 .....	119

**Additional references:**

Pressure equipment and legislation in EN .....	9
NDT of boiler tubes by ASTM (ASME SA) rules .....	31
Dimensional tolerances according to ISO 1129 standards .....	41
Galvanic protection of tube surface .....	81
Trimming the tube ends .....	96
NACE International Standards .....	97
Tube suitability for hot dip galvanizing .....	103
Carbon equivalent .....	103

**List of Tables**

Tab. No. 1 Steel classification according to STN EN 10020 .....	6
Tab. No. 2 Overview of the leak tightness testing and non-destructive testing .....	7
Tab. No. 3 Tube testing according to EN 10216 .....	8
Tab. No. 4 Indicative comparison of steels for pressure tubes for high temperature - boiler tubes .....	32
Tab. No. 5 Dimensions and weight of seamless steel tubes according to EN 10220 .....	40
Tab. No. 6 Dimensions and weight of seamless steel tubes according to GOST 8732 and TU .....	42
Tab. No. 7 Dimensions and weight of seamless steel tubes in accordance with ANSI / ASME B36.10M .....	44
Tab. No. 8 Tolerances according to ASTM A530/A530M, ASTM A999/A999M (ASME SA) .....	45
Tab. No. 9 Dimensions and weight of seamless tubes according to ASTM A450/A450M, ASTM A1016/A1016M .....	46
Tab. No. 10 Allowed outside diameter tolerances according to ASTM A450/A450M, ASTM A1016/A1016M (ASME SA) .....	47
Tab. No. 11 Allowed wall thickness tolerances according to ASTM A450/A450M, ASTM A1016/A1016M (ASME SA) .....	47
Tab. No. 12 Dimensions and weight of steel tubes according to JIS standards (Tubes) .....	47
Tab. No. 13 Dimensions and weight of steel tubes according to JIS standards (Pipes) .....	50
Tab. No. 14 Cold drawn steel tubes for heat exchangers with a minimum wall thickness (size in inches) .....	51
Tab. No. 15 Cold drawn steel tubes for heat exchangers with a medium wall thickness (size in inches) .....	51
Tab. No. 16 Cold drawn steel heat exchanger tubes (sizes in mm) .....	51
Tab. No. 17 Parameters of tubes with internal ribs .....	52
Tab. No. 18 Dimensions of tubes with internal ribs .....	53
Tab. No. 19 Dimensions for threaded tubes according to EN 10255 .....	58
Tab. No. 20a Permissible specified outside diameter and specified wall thickness .....	58
Tab. No. 20b Dimensions of pipeline tubes according to API 5L .....	59
Tab. No. 21 Indicative comparison of steel for pipeline tubes .....	59
Tab. No. 22 Dimensions of oil tubes .....	61
Tab. No. 23 Dimensions and weights of drawn precision seamless tubes according to EN, DIN, BS, UNI, NF, GOST, CSN, STN standards .....	68
Tab. No. 24 Allowed weight tolerances according to ASTM A450 and ASTM A1016 standards .....	68
Tab. No. 25 Dimensions and tolerances of drawn precision seamless steel tubes according to EN, DIN, UNI, NFA, PN-H .....	69
Tab. No. 26 Dimensions of precision seamless steel tubes, cold drawn with tighter tolerances .....	70
Tab. No. 27 Possible outside diameter tolerances for heat-treated precision tubes .....	70
Tab. No. 28 Dimensions and weight of cold drawn steel tubes according to ASTM A450 and A1016 - weight in lb / ft .....	71
Tab. No. 29 Allowed outside diameter tolerances according to ASTM A450/A450M and ASTM A1016/A1016M .....	71
Tab. No. 30 Dimensions and weights of cold drawn steel tubes according to ASTM A450 and A1016 - weight in kg / m .....	72
Tab. No. 31 Allowed wall thickness tolerances according to ASTM A450/A450M and ASTM A1016 .....	72
Tab. No. 32 Dimensions and weights of HPZ tubes for mechanical machining .....	76
Tab. No. 33 Dimensions, tolerance and weight of HP tubes .....	78
Tab. No. 34 Dimensions of HPL tubes with electroplating .....	82
Tab. No. 35 Dimensions, cross-sectional area and weight of HPL tubes .....	83
Tab. No. 36A Table of pressures for hyd. tubes (MPa) steel 37.4 (E235) without specified testing according to 3.1.B (3.1) .....	84
Tab. No. 36B Table of pressures for hyd. tubes (MPa) steel 37.4 (E235) tested by specified testing 3.1.B (3.1) .....	85
Tab. No. 36C Table of pressures for hyd. tubes (MPa) steel 52.4 (E355) without specified testing according to 3.1.B (3.1) .....	86
Tab. No. 36D Table of pressures for hyd. tubes (MPa) steel 52.4 (E355) tested by specified testing 3.1.B (3.1) .....	87
Tab. No. 37 Dimensions of precision tubes for manufacturing of bearings .....	88
Tab. No. 38 Dimensions of tube bends .....	90
Tab. No. 39 Devices and methods of tube cuts manufacturing .....	91
Tab. No. 40 Dimensions of butt welding elbows shape K (90 °) and DK (180 °) type 3D, produced by European standards .....	94
Tab. No. 41 Dimensions of butt welding elbows, manufactured according to ASME (ANSI) B 16.9 standards .....	95
Tab. No. 42 Allowed sizes and shapes tolerances of butt welding elbows .....	98
Tab. No. 43 Dimensions of concentric reduction - Type 1 .....	99
Tab. No. 44 Dimensions and dimensional tolerances of steel blooms - square cross-section .....	100
Tab. No. 45 Dimensions and dimensional tolerances of steel blooms - circular cross-section .....	100
Tab. No. 46 Indicative comparison of steels - steels for alloy treatment and cementation - carbon, type C according to EN .....	107
Tab. No. 47 Indicative comparison of steels - steels for tubes for machine parts - carbon, type E according to EN .....	109
Tab. No. 48 Indicative comparison of steels - steels for pipelines, type L according to EN .....	110
Tab. No. 49 Indicative comparison of steels - steels for tubes for the pressure purpose, type P according to EN .....	111
Tab. No. 50 Indicative comparison of steels - steels for tubes for steel structures, type S according to EN .....	113
Tab. No. 51 Indicative comparison of steels - steels for tubes for pressure purposes - alloyed, type 16Mo3 according to EN .....	114
Tab. No. 52 Indicative comparison of steels - steels for tubes for machine parts and chemical and thermal treatment - alloyed, Type 26Mn5 by EN .....	115
Tab. No. 53 Comparison of fine-grained steel according to DIN and EN .....	116
Tab. No. 54 Conversion table for inches and decimal values .....	117
Tab. No. 55 Standard wire gauge for a wall thickness .....	117
Tab. No. 56 Comparison of tensile strength and hardness according to Vickers, Brinell and Rockwell hardness .....	118
Tab. No. 57 Designation system for steels: EN 10027 -2 .....	119

## Standardization companies and standards

**International, globally valid standards are issued by two standardization organizations based in Geneva:**

**ISO (International Standards Organization)** – issues general standards.

**IEC (International Electrotechnical Commission)** – Issues standards for electrical engineering.

ISO standards apply globally and therefore usually they are not taken into the system of national standards. For steel tubes they are not frequently used. However, just for information, we show them in this handbook.

### European standardization

it is organized like the global one, however has up to three commissions. The first two are based in Brussels, the third in Sophia Antipolis (France):

**CEN (Comité Européen de Normalisation)** – issues general standards in Slovak referred to as European standards (EN). These EN standards can not be equated with previously issued EuroNorms. Standards for iron and steel are issued by the European Committee for Standardization of Iron and Steel (ECISS) and the relevant Technical Committees (TC) and subcommittees (SC).

**CENELEC (Comité Européen de Normalisation Electrotechnique)** – issues electrotechnical Standards

**ETSI (European Telecommunications Standards Institute)** – publishes standards for telecommunications.

### National standard institutes (offices)

Issues national standards. In the context of enlargement of the European Union, the EN standards are accepting (implementing) into the system of national standards (technical harmonization of standards). Unlike ISO standards EN standards are implemented without modification and nowadays they must repeal all conflicting national standards. In this context, there also has been a major change in the philosophy of the use of standards.

In the past, compliance with the provisions of standards was mandatory. Now two concepts appear to stand out: the validity and obligation of standard. The standard is valid, but, besides few exceptions its observance is not mandatory/binding. The standard specifies the recommended technical requirements which they do not have to be used. On the other hand two circumstances are standing out:

- if the standard is specified into the contract between the seller and the buyer then it becomes part of the contract and its requirements must be met
- if damages incurred as a result of solution, which have not met the requirements of the harmonized standards, the responsibility rests with those who did not meet the requirements of generally formulated by government regulation, because by the law, if STN assumes harmonized EN, it also become harmonized, and after its publication in the Bulletin, this standard can be used for assessing compliance with the technical requirements laid down by the government.

### Other standards

Under consideration comes mainly the company standards. They can not be in conflict with national standards.

Another group are the standards of professional societies, e.g. in the USA (AISI, ASTM, ASME, API, SAE).

Trading partners among themselves can enter into bilaterally binding technical and delivery conditions or technical specifications.

### Technical Standards

They are part of the legislation in force for the given area of industrial products. Specifically the linking of regulations set out for the individual tube groups.

## Steel tubes

### - Classification, terminology and definitions

Referred concepts for steel tubes are in STN (ČSN) 42 0044, 42 0045, 42 0046, EN 10079, ISO 6929 standards.

**Tube classification** is based on a number of points of view: the production method, the cross-sectional shape, treatment of tubes ends, and range of application of tubes.

**According to EN 10079** tubes belong to so-called long products. It is a product that has along the entire length permanent circular, or other hollow cross-section, it is open at both ends and has a relatively large length (ISO 6929).

**According to the production method** we distinguish between two large groups of tubes – seamless and welded. Each of this group can be divided according to the method of tube production (hot rolled and cold rolled production).

Part of tube group is also so called **hollow profiles**. They are seamless or welded tubes of circular, square or rectangular cross-section, used for production of steel structures for building industry or even for machine parts.

**Hollow bars** are seamless tubes of circular cross-section intended for the manufacture of machine parts by chip machining. From the first two groups of tubes they differ in qualitative and dimensional parameters that are chosen to meet the requirements for workability, heat treatment and surface quality components.

In this manual the products are **classified by application**, taking into account the method of production. Similarly are set up also the new EN steel tube.

### Technical standards for steel tubes

Technical characteristics of the steel tubes are concentrated in the relevant technical standards.

Tube parameters can be divided into three main groups:

- dimensions and their tolerances (depending upon production method of tubes)
- type of steel and steel conditions (supply)
- technical delivery conditions

Individual national standardization bodies use different procedures for data standardization for steel tubes. In practice, three options are used:

- each main group of parameters is contained in a single standard. Standards are linked by references to related standards. Dimensional standard includes a table of dimensions and their tolerances, steel standard contains its chemical composition and mechanical properties for various methods of tube manufacturing and condition of steel. The third standard of the technical delivery conditions (TDC) establishes all other requirements for tubes such as testing, acceptance, certificates, packaging, markings and the like. At the same time includes references to additional standards, where these activities are described (e.g. STN, ČSN standards).
- the second option is, when steel and its characteristics are included in the TDC standard and this includes the dimensional tolerances. The tube is described by two standards – dimensional, containing dimensional table and TDC standard (e.g. DIN standard).
- the third option – tube parameters are in one standard which contains also the dimensional table or selection from the general table of dimensions, which is the content of general dimensional standard (e.g. NFA, EN standards).

In practice, there are also cases where the seller and buyer enter into bilateral or TDC or the tubes are supplied according to the technical specifications of the buyer.



## Overview of the main characteristics of steel tubes

This chapter is a general description of the characteristics that serve as the basis for the description of individual particular types and groups of steel tubes. These are:

- Tube dimensions
- Steel for tubes
  - The definition and distribution of steel
  - System of marking steel for the tubes according to EN
- Technical delivery conditions (TDC) for tubes (excluding testing)
- Test of tubes
  - Types of testing
  - Types of inspection documents
  - Individual tests

### The tube dimensions

The tube dimensions are fundamental characteristics of tubes. For industrial purposes and general use the tubes are manufactured with diameters ranging from tenths of a millimeter to the diameter of a few meters.

Tube size must be given in such a way that it is fully defining the tube in this regard. For tubes of circular cross section, besides the length, three main dimensions emerge: outside diameter, inside diameter and wall thickness. For circular tubes two of the values are given. According to tube type the relevant dimensional tolerances are assigned to dimensions.

Dimensions of individual tubes are not created randomly, but are arranged according to the dimensional array of a specific system. The tube dimensions are in mm, in the USA and some other countries are given in inches (English „inches“, German „Zoll“). In this case, the tubes are also classified into two groups - „Tube“ are tubes for mechanical usage and for energy facilities and in inches is given the actual outside diameter. „Tubes“ are tubes used in pipelines for different types of media. Tubes size is given as nominal tube size, and up to 12 inches is given approximate size (luminosity) of the internal diameter of the tube (in more detail in the relevant types of tubes).

From dimensions of tubes after conversion to millimeters used in the SI system is created first and preferred array of outside diameters of steel tubes (1st series in EN 10220, DIN 2448, etc.). This does not mean that the tubes in the 2nd and 3 series are not used in practice. Dimensions in series 2 and 3 (for use in Europe are supplemented by the rounded off dimension in mm) are the standards for tube, used in the construction of power facilities and for tubes for mechanical usage.

The group of wall thicknesses has its origin in the inch system, which is used to express the size fractions. Wall thickness in Tubes forms the array of „Schedule“ (40, 60, 80, 120, ...), connected in some dimensions to the weight category (STD, XS, XXS). These values are converted to millimeters and form a group wall thickness. (Note: size - the value of Schedule e.g. 40 is not constant, but depends on the outside diameter of the tube). For Tube wall thickness the values are derived from the „scales“ BWG, SWG, possibly others. After conversion to mm, these values become part of tube wall thickness group for steel tubes.

For precision steel tubes used in Europe and in countries using SI units we established dimensional series with rounded off dimensions of the outside diameters and wall thicknesses.

### Ovality, eccentricity

Ovality (O) (non-circularity) is defined as the difference between the largest and smallest outer diameter at a given cross section of the tube. Ovality is allowed under framework of the outside diameter tolerances (EN 13 508).

$$O = D_{\max} - D_{\min} \text{ (absolute value in mm)}$$

$$O = 100 \cdot (D_{\max} - D_{\min}) / D_{\text{nominal}} \text{ (in\%)}$$

**Eccentricity (E)** (eccentricity) is a measure (size) of the difference between the centers of the outer and inner diameter. Eccentricity is permitted within the tolerances of wall thickness and is calculated from the thickness of the walls in one cross section:

$$E = (T_{\max} - T_{\min}) / 2 \text{ (absolute value in mm)}$$

$$E = (T_{\max} - T_{\min}) / (T_{\max} + T_{\min}) \cdot 100 \text{ (in\%)}$$

Tolerances (deviation limits) for outside diameter, inside diameter and wall thickness are always valid for only two ordered values. Limits of the third dimension can be arranged only for precision tubes.

**Tube straightness deviation (e)** indicates the maximum deviation of the tube from a line joining its two ends, where L is the length of the tube. It is given in percentages per unit length.

$$e / L \times 100\%$$

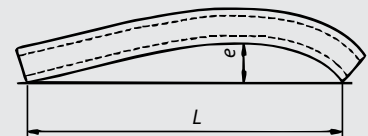

### Tube weight

**A theoretical weight (M) is calculated by the formula:**

$$M = 0.0246615 \times (D - T) \times T \text{ [kg/m], } D, T \text{ [mm]}$$

$$M = 10,69 \times (D - T) \times T \text{ [lb/ft], } D, T \text{ [in]}$$

This applies to carbon steel. For other types of steel, the value multiplied by the coefficient:

Type of steel	Specific weight	Coefficient
Carbon	7,85 kg.dm-3	1
Austenitic stainless	7,97 kg.dm-3	1,015
Ferritic and martensitic	7,73 kg.dm-3	0,985

The standards set out the permissible tolerances for tube weight from the theoretical weight.

Calculated table weight of pipeline tubes in **kg / m** (Table 7/Page 44 and Table 20/Page 59) may vary depending on whether in the calculation we used tube wall thickness in mm rounded off to one decimal place (release API 5L Standard until 2004), or to two decimal places (dimensions according to ASME B 36.10M regulation currently in force even for pipeline tubes according to API 5L Standards).

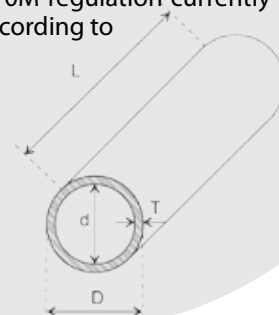

## Steel for tubes

Definition and classification of steel according to **EN 10020** - steel is defined as:

- material where weight portion of iron is higher than that of any other element
- content of carbon (C) is less than 2%, which is the current limit between steel and cast iron (except some Cr-steel, which may also contain more than 2%)
- steel contains other elements listed in the following table.

Table shows limit values for the elements of unalloyed and alloyed steel - column. No. 1 Limit values of chemical composition quality and grade steel - column. No. 2

Element		Weight proportion in %	
		1	2
Al	Aluminum	0,30	
B	Boron	0,0008	
Bi	Bismuth	0,10	
Co	Cobalt	0,30	
Cr	Chrome	0,30	0,50
Cu	Copper	0,40	0,50
La	Lanthanide (each)	0,10	
Mn	Manganese	1,65	1,80
Mo	Molybdenum	0,08	0,10
Nb	Niobium	0,06	0,08
Ni	Nickel	0,30	0,50
Pb	Lead	0,40	
Se	Selenium	0,10	
Si	Silicon	0,60	
Te	Tellurium	0,10	
Ti	Titan	0,05	0,12
V	Vanadium	0,10	0,12
W	Tungsten	0,30	
Zr	Zircon	0,05	0,12
Other elements (except: carbon, phosphorus, sulfur, nitrogen), (each)		0,10	

The coefficients for the determination of the eigenvalues for the alloying elements content

Element	Coefficient
Cr, Co, Mn, Ni, Si, W	4
Al, Be, Cu, Mo, Nb, Pb, Ta, Ti, V, Zr	10
Ce, N, P, S	100
B	1000

Note - Alloy Steel:

- 1 Is defined also in EN
- 2 Applies cast analysis
- 3 Minimum content of each element - see table
- 4 If there is the highest content of an element given, than for classification use 70% of this value (with the exception for Mn)

## System for steel marking for tubes according to EN

- EN 10027-1** identification systems of steel.  
**(ISO / TS 4949)** Abbreviated designation system. The basic symbols  
**EN ECISS IC10** The supplementary symbols  
**EN 10027-2** System of number marking

According to **EN 10027-1** steel grades are divided into two main groups:

- Group 1 - Steel designated according to the usage and mechanical or physical properties
- Group 2 - Steel designated according to chemical composition. These are divided into four sub-groups.

### Group 1

- S - structural steel for general use
- P - steel for pressure purposes
- L - steel for pipelines
- E - steel for machine parts (subsequent number indicates the minimum yield strength in N/mm<sup>2</sup>)
- B - steel for the reinforcement of concrete
- Y - steel for prestressed concrete reinforcing
- R - steel for rails
- H - flat cold rolled products
- D - flat products made of mild steel for cold forming
- T - sheets and strips
- M - sheets and strips for electrical purposes

For tubes are used the first four types of steel

### Group 2 - has 4 subgroups

- **non-alloy steel** (with regulated content of C) - marking: letter C and the number corresponding to one hundred times the mean range of the prescribed range for the content of carbon (C22)
- **non-alloy steel** with the content of Mn > 1% and **alloy steel** with content of individual alloying elements below 5% - marking:
  - a) the number corresponding to the hundredfold carbon content
  - b) chemical symbols of alloying elements in order of decreasing content of elements
  - c) numbers, which are defined by the alloying elements. Mean element content multiplied by the factor from the table and rounded to the higher whole number (25CrMo4).
- **alloy steel** with alloying addition (at least one element above 5%) - marking:
  - a) typical letter **X (X11CrMo9-1)**
  - b) number - one hundred times the mean carbon content
  - c) chemical symbols of alloying elements
  - d) numbers, which are defined by the alloying elements. Mean element content rounded off to the higher whole number.
- **speed steel** - designation
  - a) typical letters **HS (HS 6-5-2)**
  - b) numbers, which are defined by the alloying elements

Regulation **EN ECISS IC10** establishes additional symbols for **steel** (Groups 1 and 2). These symbols are placed at the end of the steel mark (e.g. S 275 J0). Additional symbols for **steel products** are given in Tables 1, 2, 3 and from the previous symbols must be separated by a plus sign (+) - e.g. S 275 J0 + A.

**Symbols for steel tubes**

- G - other characteristics (if necessary 1 to 2 digits)
- H - hollow profile or for higher temperatures steel according to the type of steel (S, P)
- L - steel for low temperature
- R - steel for common temperature (room temperature)
- M - thermomechanically rolled
- N - normalized or normalized rolled
- Q - heat treated
- T - steel for tubes

**EN 10027-2** contains the numerical system marking. The first number is 1 - steel, followed by two digits of steel group and the serial number of steel (**1.0402, 1.7218, 1.7386, 1.3339**).

See Tab. No. 57 on page 119

**Indicative comparison of old and new labeling of the European basic structural steel (steel group 1)**

In addition to introducing the letters for the field of application of tubes (S, E, P, L, etc.) two changes occurred:

- 1 Instead of the minimum value of tensile strength Rm is now in the steel marking listed value of the upper yield strength **ReH**
- 2 Old units kp/mm2 were replaced with new units N/mm2 (**MPa**).

Example:

Old steel markings:

Type of steel St35, St35.8, St37.0, St37.4, ČSN 11353, etc. have values in the old units:

Re min. = 23.5 kp/mm2, Rm min. = **35 kp/mm<sup>2</sup>**.

New steel markings:

Identical resp. similar to steel 235JRH S, E 235, P 235TR1 etc. have similar mechanical properties in new units:

Re min. = **235 MPa**, Rm min. = 340-360 MPa.

**Steel classifications according to STN EN 10020**

**Table 1**

Steel quality groups according to the chemical composition		Steel classifications in the main quality groups		
<b>NON-ALLOY STEEL</b>	>	<b>NON-ALLOY QUALITY STEEL</b>		<b>NON-ALLOY SPECIAL STEEL</b>
Contents of the elements does not reach the values listed in the table		For general requirements: - Impact energy - Grain size - Formability	+	Intended for refining and surface hardening etc.. Guaranteed minimum absorbed energy. Low content of non-metallic inclusions
<b>STAINLESS STEEL</b>	>	<b>BASIC PROPERTIES</b>		
Content of C. 1.2% max Content of Cr 10.5% min Content of Ni is less than 2.5% or higher than 2.5%				Corrosion resistant steel Creep resistant steel Heat resistant steel
<b>OTHER ALLOY STEEL</b>	>	<b>ALLOY QUALITY STEEL</b>		<b>ALLOY SPECIAL STEEL</b>
This is not stainless steel, content of at least one element reaches values in the table on the previous page		fine grained structural steel steel for rails and girders steel for heavy use alloy steel by Cu steel for electrical engineering	+	structural steel for pressure vessels for roller bearings tool steel high-speed steel special physical properties

• Classification of steel is also in ISO 4948-1 and ISO 4948-2



## Technical delivery conditions (TDC) of tubes

All tube requirements are concentrated in the TDC standards. The particulars are detailed for the individual types of tubes. An important part is the testing of tubes. Summary of the tests is given in the following chapter. The general TDC for steel and steel products are in EN 10021 standard. Symbols and definitions are in EN 10266. General TDC is also in ISO 404.

### Tube testing

Tube testing demonstrates that properties of the tubes are consistent with the requirements of the order and the relevant standards. The process is divided into three parts:

- determination of the type of test (EN 10021, EN 10204)
- determination of the type of inspection document (EN 10204, ISO 10474)
- selection of individual tests (particularly TDC)

The individual parts are connected and there is no possibility of any combination. Self testing is determined by TDC standard for the individual types of tubes.

#### • Non-specific and specific testing

##### Unspecified testing

- contains only mandatory tests according to the appropriate standard
- the test samples do not have to be from their own delivery
- testing station does not have to be independent at the tubes treatment plant

##### Specific testing

- besides the mandatory tests it contains additional optional tests
- samples of tubes are from supplies, their number is set by standard
- testing station must be independent at the tubes treatment plant

#### • Tests

- mandatory - according to the TDC standard
- optional - agreed when ordering tubes from selection according to standards

#### • Quality - TR 1, TR 2 depends on:

- chemical composition (Al content)
- values of mechanical properties (bending impact test)
- the type of test of tubes (specific and non-specific testing)

#### • Quality - NL1 and NL2 (steel grades for low temperatures)

- depends on:
  - chemical composition (S content)
  - values of mechanical properties (bending impact test)
- NL1 – use in low temperature
- NL2 – use in especially low temperature

#### • Test category - TC1 and TC2 depends on:

- provisions of standard
- chemical composition (carbon and alloy steel)
- the possible option when ordering of tubes (in C steel)

The categories differ from each other mainly by demand for nondestructive testing of tubes, or selection of tests.

#### • Documents about testing

Overview of kinds of attests in accordance with EN 10204 depending on the kind of testing:

##### Unspecified testing

- 2.1 Company confirmation (confirmation from the manufacturer, without the test results)
- 2.2 Company non-specific certificate (certificate from the manufacturer, the test results on the basis of unspecified testing)

##### Specific testing

- 2.3 Company specific certificate, test results based on specific testing. It is issued at this kind of testing when the manufacturer has no independent testing laboratory. If the laboratory is independent, instead of this certificate the 3.1.B certificate is issued.

3.1.A Inspection Certificate 3.1.A (officially appointed expert)

3.1.B Inspection certificate 3.1.B (company expert)

3.1.C Certificate 3.1.C (expert from customer)

3.2 Report 3.2 (company expert and expert from customer)

#### Release EN 10204 : 2004, ISO 10474 : 2013

2.1 Statement of compliance with the order

2.2 Test report

2.3 Not considered

3.1 Inspection certificate 3.1 (formerly 3.1.B)

3.2 Inspection certificate 3.2 (formerly 3.1.A, 3.1.C, 3.2)

In the EN is the Table - Context of categories of systems according to Directive 97/23 EC, Annex I, section 4.3, and the type of certificate.

#### The tests are divided into groups:

- **control of the chemical composition of the steel** - cast  
- product

#### • dimensional inspection

#### • mechanical properties \*

- tensile test
- (Hardness)
- bending impact test

#### • technological tests \*

- flattening
- drift expanding
- flanging
- bending
- ring tensile test
- hydrostatic pressure
- non-destructive methods

#### • water tightness test

- **Non-destructive testing** - longitudinal imperfections  
(Eddy current, stray fluxes, - transverse imperfections  
ultrasound) - laminar imperfections

#### • further testing (metallography, corrosion resistance, etc.).

- report attached on page 102 - 104

## Overview of the leak tightness tests and non-destructive testing

Table 2

Method	STN, ČSN	DIN(SEP)	EN ISO	ASTM	Dimensions	ISO
<b>Leak tightness tests</b>						
<b>Hydrostatic pressure</b>	42 0415.8	TDC Standards			D < 140 mm	
<b>NDT</b>	01 5047 01 5049 01 5054	SEP 1925	10 893 - 1		see NDT	9302
<b>Non-destructive tests (NDT)</b>						
<b>Eddy currents</b>	01 5054	(PRP 02-74)	10893 - 2	E 309	D > 4 mm, T > 0,5 mm	9304
<b>Stray fluxes</b>	01 5047	SEP 1913	10893 - 3	E 570	D > 32 mm, T > 2 mm**	9402
<b>Ultrasound</b> - L longitudinal imperfections	01 5028 - 2	SEP 1915	10893 - 10		D > 13 mm, T > 1(2) mm**	9303 9305
<b>Ultrasound</b> - Q transverse imperfections	01 5028 - 3	SEP 1918	10893 - 10	E 213		
<b>Ultrasound</b> - D laminar imperfections	01 5028 - 4	SEP 1919	10893 - 8			
Tube lengths - see the survey table for each group of tubes						

Notes: 1) \*\* values apply to ŽP, a.s.

## Leak tightness testing and NDT for pressure tubes according to EN standards

### Tube testing according to EN 10216 standard

Table 3

EN 10216 – 1	EN 10216 – 2, 3, 4
Quality TR 1 or TR 2	Testing category TC 1 or TC 2
Carbon steel - the type of quality is a part of steel brand	Carbon steel - choice of TC1 or TC2 Alloy steel - only TC2
<b>1. Leak tightness testing</b> Required for all tubes. Select from the methods: <b>1.1 Testing by internal overpressure</b> Selection is from the lesser value of pressures: 1.1.1 70 bar 1.1.2 the pressure value according to the formula $P = 20x(SXT) / D$ , where $S = 70\%$ of the minimum specified yield strength in MPa (pressure in bars) <b>1.2 Non-destructive testing according to EN ISO 10893-1 (E)</b> Electromagnetic testing - Eddy current. Preference from the methods: 1.2.1 encircling coil - the diameter of the borehole in reference to standard is dependent on the tube diameter D (Table is in the standard) 1.2.2 rotary probe coil – reference standard notch with depth of 12.5% of nominal wall thickness T (min. 0.5 mm, max 1,5 mm). Notch width is less than depth, length min 50 mm	
<b>2. Non-destructive testing - longitudinal imperfections</b>	
<b>2.1 Quality TR2</b> select from: 2.1.1 Eddy current (E) - EN ISO 10893-2 2.1.2 Stray flux (F) - EN ISO 10893-3 2.1.3 Ultrasound (U) - EN ISO 10893-10 Class of eligibility 3, subclass C	<b>2.2 Testing categories TC2 mandatory</b> select from: 2.2.1 Ultrasound (U) - EN ISO10893-10 Class of eligibility U2, subclass C 2.2.2 Stray flux (F) EN ISO10893-3 Class of eligibility F2 <b>Transverse defects (2.3) and laminar (laminar defects) (2.4) - testing only after agreement - Ultrasound</b> 2.3 Test for transverse defects EN ISO 10893-10 U2C 2.4 Test for duality EN ISO10893-8 U2 2.5 Measurement of wall thickness EN ISO 10893-12

In practice, pressure tubes are assigned into testing categories type TC2, tested by combining two non-destructive tests:  
 - Eddy current testing (testing leak tightness). Testing by overpressure at the request of the customer by agreement.  
 - Ultrasound for longitudinal defects (non destructive testing).

Legend and comments      NDT - Non-destructive examination (testing)  
 EN 10216-1 - Standard contains only carbon steel

### Testing methods

**E - Eddy Current - eddy current** (EN ISO10893 - 1 and 2). (Tests marked in overview 1.2.1, 1.2.2 and 2.1.1)  
 Encircling coil - levels of permissibility E1H, E2H, E3H, E4H (hole diameter in the reference standard, depending on the diameter of the tube D - see the table in the standards)

Rotary probe coil - levels of permissibility E2, E3, E4, E5. Testing the tubes with  $D \geq 4$  mm.

**F - Flux Leakage - stray flux** (EN ISO10893-3). (Tests marked in overview 2.1.2 and 2.2.2)

Levels of permissibility F2, F3, F4, F5, F6. Testing the tubes with  $D > 10$  mm.

**U - Ultrasound** - longitudinal imperfections EN ISO 10893 -10  
 - Transverse imperfections EN ISO10893-10  
 - Duality EN ISO10893 - 8 (for a wall thickness of 5 mm)  
 - Check the wall thickness EN ISO10893 -12 (from 4.5 to 5 mm of wall thickness)  
 (Tests marked in overview 2.1.3, 2.2.1, 2.3, 2.4 and 2.5.)

Levels of permissibility to EN ISO10893 - 10 - U1, U2, U3, U4, U5, U6

Subclasses A, B, C, D. Testing the tubes with  $D \geq 10$  mm and the ratio  $D/T > 5$  For smaller values by agreement, below the value of 4 the ultrasound test is not performed.

Levels of permissibility and the notch depth of a standard in % of the wall T:

1	3
2	5
3	10
4	12,5
5	15
6	20

Subclass - minimum depth of the notch (mm)

A	0,1
B	0,2
C	0,3
D	0,5

Subclasses A, B, C, D are valid for cold formed and machined tubes. Subclass C and D are valid for hot rolled tubes.

Other values of acceptance levels as in EN - after agreement.

Testing for transverse imperfections, duality and checking the wall thickness - only after agreement.

**For testing according to ASTM and API 5L** - see page 102 (leakage test), page 31 (NDT)

## Quality management systems certification, legislation

Handbook is primarily aimed at providing an overview of the technical parameters steel tubes produced by Podbrezová Železiarne, a.s. and Transmesa SAU. The tubes themselves and also the products and equipment whose parts consist of the tubes must also comply with the relevant national or industry laws, decrees and regulations designed to ensure the safety of operation, health and the environmental protection. Also the quality management system shall be in accordance with the relevant regulations and must be certified by authorized company.

### Management of quality

consists of several steps:

- certification of the quality management system according to international standards ISO 9001
- certification of the quality management system according to specific technical regulations
- certification of products and Approbation of products. This section consists of three areas:
  1. Product certification - certification that products are manufactured according to the standards and meet the requirements of the regulations (e.g. EU regulations)
  2. Products for construction use - Attestation of Conformity
  3. Approbation of products - affirmation of companies authorized to accept the tubes that the products comply with relevant standards

### Environmental Management System

For the introduction of the Environmental Management System (EMS) and its certification the ISO 14001 standard applies.

### Safety at work

Requirements for the management of health and safety protection at work are included in the international standard OHSAS 18001.

### The legislation

Steel tubes are divided accordance to their use to individual groups, where they are subject to different types and degrees of superior regulations. In the countries of European Union (EU) the **Directives** are valid for the relevant groups of products. Following the publication the individual countries must include them into their national legislation and **technical standards**.

**The Directives** stand out in the relevant documentation under the double designation. The Directorate-General (DG) elaborates proposal for the directive. Steel tubes are covered by DG Enterprise and Industry. Then based on the proposal of the European Commission's they are approved by the European Parliament. The Directives are marked as follows:

Year of issue / number /EEC respectively EC or if necessary EU (European Economic Community, after 1992 or 1993 only European Community).

These Directives acquire the Legal authority after they are issued in the Official Journal of the European Communities (Official Journal (EU - Collection of Laws, where the directive is placed under the corresponding number of law into this collection). In this Collection it is marked as OJ L number and date.

**EN standards** set out the requirements for specific groups of tubes.

In terms of legislation, there are three important group types of steel tubes:

- tubes for construction use
- tubes for pressure purposes
- tubes for parts of machines

### Tubes intended for construction use

They are classified as finished products and in placing them on the market, and as of 1.6.2013 a new legislation is valid for them.

- Regulation of the European Parliament and of the Council (EU) No. 305/2011 (CPR), by which they are establishing harmonized conditions for introduction of construction products on the market and repealing Council Directive 89/106 of EEC. Address-

ses the assessment and verification of the constancy of parameters of construction products and its introduction on the market by means of harmonized technical specifications.

- Harmonized technical specifications: harmonized EN and European Technical Assessment (ETA) issued on the basis of European Assessment Documents (EAD)
- Declaration of parameters (DoP) - issued by the manufacturer based on our assessment and verification of the constancy of performance and shall affix the CE mark.

Valid for tubes according to EN 10210, EN 10219, EN 10224, and EN 10255.

(EU) Regulation 305/2011 is directly applicable therefore does not need to be transformed into national legislation.

### Tubes for pressure purposes

#### Pressure equipment and legislation in EN

Brief Overview of the European regulations for pressure equipment with respect to the materials used:

1. Directive of the European Parliament and the Council 97/23 EC (PED 97/23 EC) applicable to specified pressure equipment. Pressure equipment within the meaning of this Directive withstand max. allowable pressure (PS) greater than 0.5 bar, and it is a pressure above the normal atmospheric pressure, i.e. excess pressure.
2. According to the Directive PED 97/23 EC pressure equipment is divided into three types, which are subject to the harmonized EN standards:

2.1 Steam and hot water boilers - EN 12952 and EN 12953

2.2 Pressure Vessels (unheated) - EN 13445

2.3 Metallic industrial pipeline - EN 13480

3. Parts 2 of these harmonized standards prescribed materials used for construction of equipment which is exposed to pressure. (In the case that other materials are used than those listed in Part 2 of the quoted standards, it is up to assessment whether these materials need to use a special procedure). Steel tubes must be supplied in accordance with EN 10216-2, EN 10216-3, EN 10216-4, EN 10217-2, EN 10217-3, EN 10217-4, EN 10217-5, EN 10217-6 (for carbon and low alloy steel).

Note: in the past, even on the international scale, the German regulations for pressure equipment TRD, TRB, TRR, AD-Merkblatt were used. For the transition period regulations AD2000 - Merkblatt were prepared, where the steel is according to EN.

### Tubes for mechanical application and machine parts

For Machinery see directive (Machinery Directive) No. 1998/37/EU For supplies of tubes for the automotive industry it is necessary that the supplier was certified according to ISO / TS 16949 regulations and (or) VDA regulations series 6.

ISO / TS 16949 regulation provides special (additional) requirements for the application of ISO 9001 standard in organizations for production of automobiles and their spare parts.

ISO 16949 regulations is by the individual producers further adapted to their specific needs.

Regulation were issued by organizations IATF - International Automotive Task Force (International Automotive Industry Association) and JAMA - Japan Automobile Manufacturers Association (Japan Automobile Manufacturers Association)

Regulation VDA 6 are quality standards of the German Automotive Industry Union (Verband der Automobilindustrie)

Regulation VDA 6.1 provides a quality management system audit (QM - System)

# Flow diagram of the production in joint stock company Železiarne Podbrezová

## Steel production

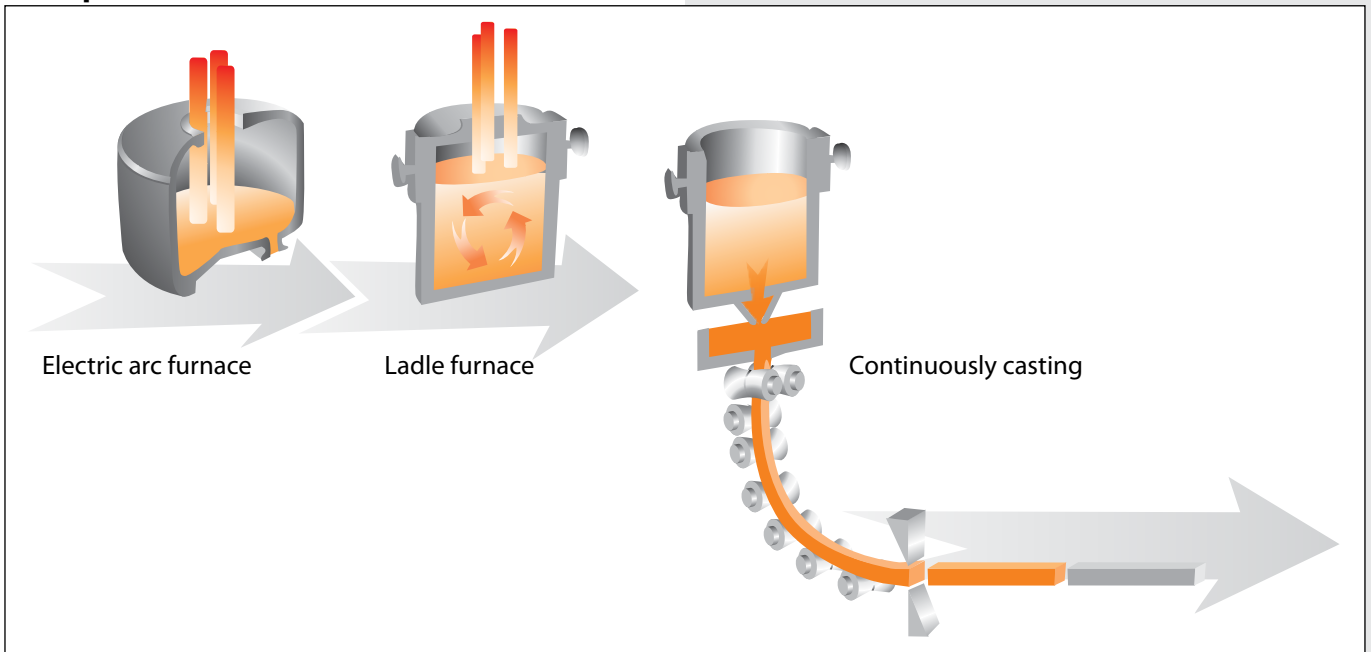

## Hot finished tubes production

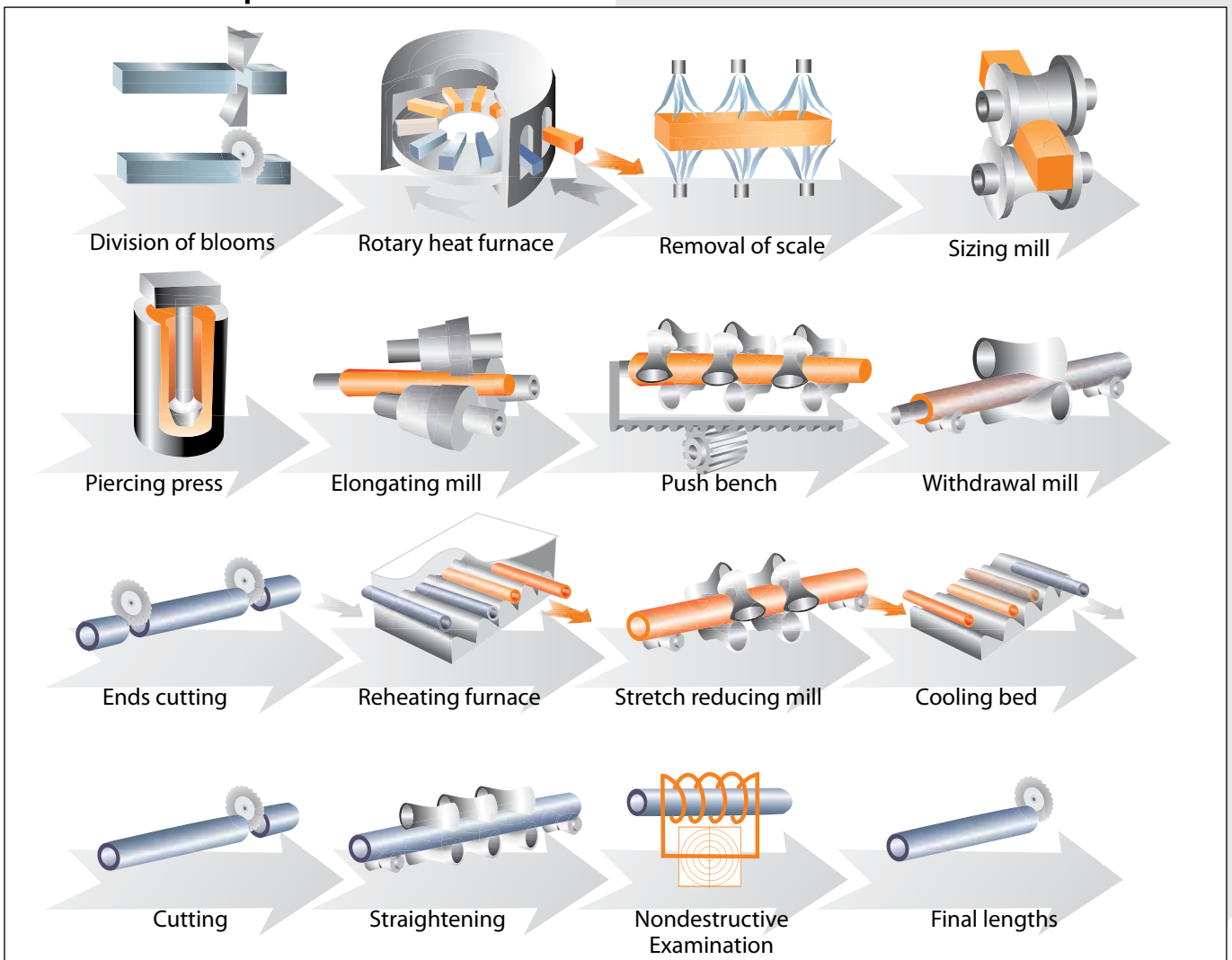

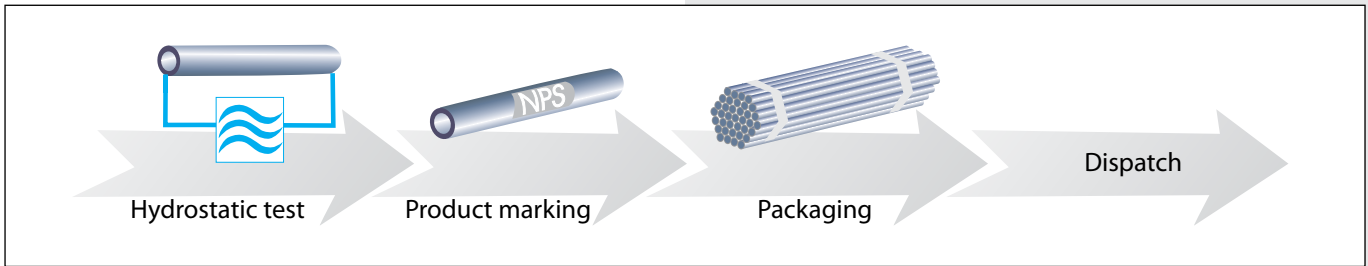

**Precision cold drawn tubes production**

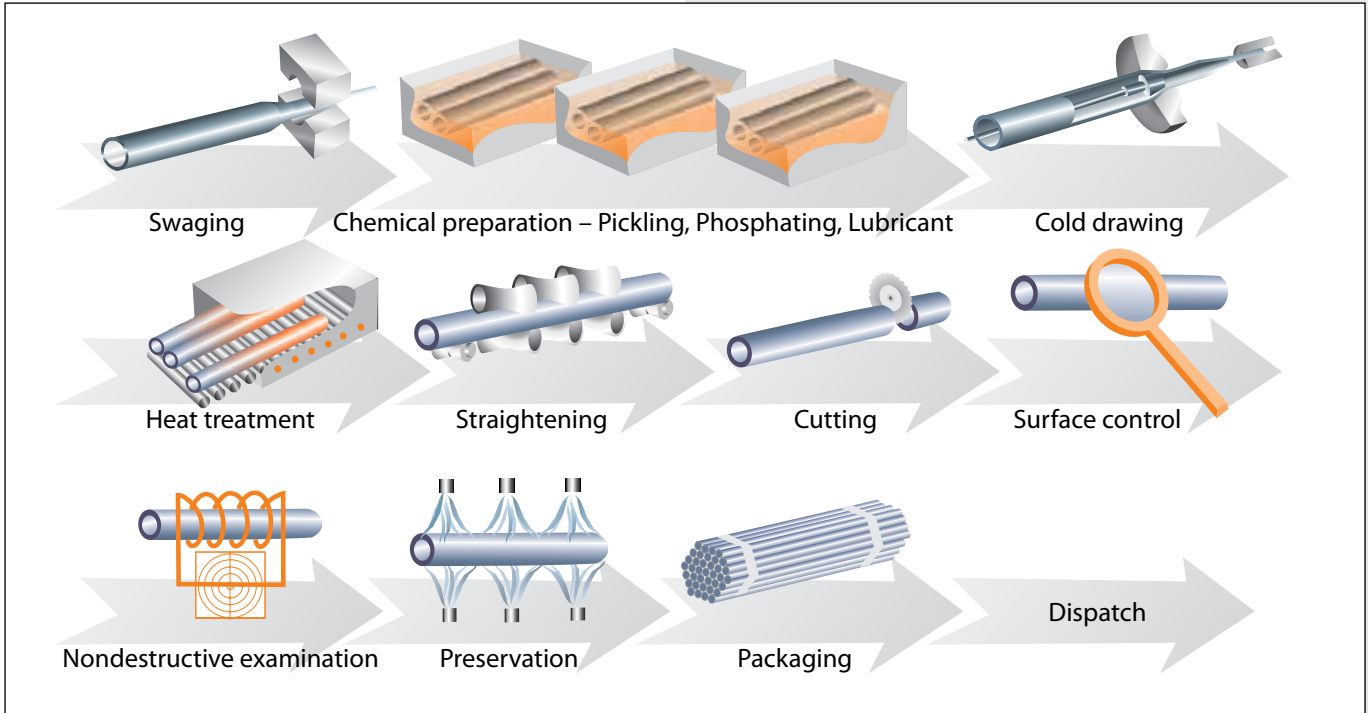

**Semiproducts fabrication**

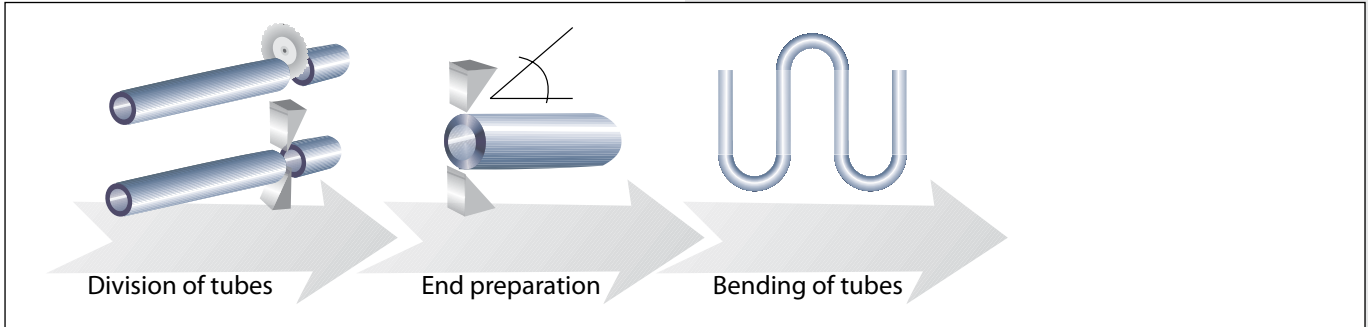

**Buttwelding fittings production**

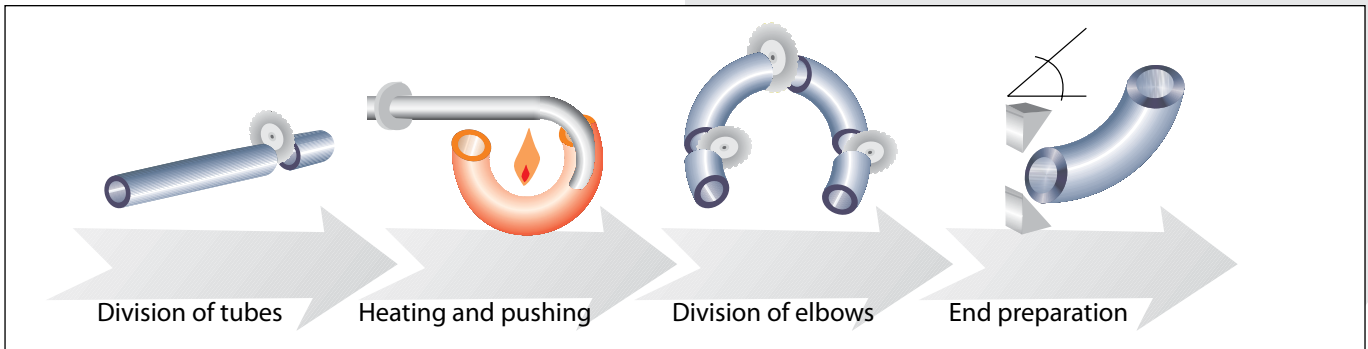



## Production program – products classification by application

<b>Seamless steel tubes for building and mechanical and general use</b>	<b>Page 14</b>
<b>Steel tubes for building (hollow structural sections)</b>	<b>Page 14</b>
<b>Tubes for mechanical and general engineering</b>	<b>Page 16</b>
<b>Tubes for machining</b>	<b>Page 16</b>
<b>Tubes for machine parts and general use*</b>	<b>Page 16</b>
<b>Precision tubes and HPL tubes (seamless)</b>	<b>Page 62</b>
<b>Seamless steel tubes for pressure equipments</b>	<b>Page 22</b>
<b>Tubes with specified room temperature properties</b>	<b>Page 22</b>
<b>Tubes with specified elevated temperature properties - boiler tubes</b>	<b>Page 26</b>
<b>Alloy fine grain steel tubes for pressure equipments</b>	<b>Page 34</b>
<b>Tubes with specified low temperature properties</b>	<b>Page 36</b>
<b>Tubes for heat exchangers</b>	<b>Page 48</b>
<b>Tubes with internal riffling</b>	<b>Page 52</b>
<b>Pipes suitable for welding and threading</b>	<b>Page 54</b>
<b>Line pipe</b>	<b>Page 56</b>
<b>Casing and tubing (upon agreement)</b>	<b>Page 60</b>
<b>Precision cold drawn seamless steel tubes</b>	<b>Page 62</b>
<b>Standard precision tubes</b>	<b>Page 62</b>
<b>Tubes for automotive industry</b>	<b>Page 73</b>
<b>Injections tubes (for Diesel engines)</b>	<b>Page 74</b>
<b>Tubes galvanized with PVC coating</b>	<b>Page 74</b>
<b>Special tubular sections</b>	<b>Page 74</b>

**Cylinder tubes (for mechanical treatment – HPZ) Page 75**

**Cylinder tubes (HP – „ready to use“) Page 77**

**Tubes for hydraulic and pneumatic lines – HPL Page 79**

**Bearings tubes Page 88**

**Precision tubes delivered in coils Page 89**

**Tube semiproducts Page 89**

**Buttwelding steel pipe elbows Page 91**

**Buttwelding steel pipe reducers Page 98**

**Continuously cast steel blooms Page 100**

## Overview of the TDC for tube groups by usage

Tube group	EN	DIN	BS	NF A	UNI	ČSN, STN	GOST	PN-H	ASTM A ASME SA	JIS	ISO	
Hollow structural sections - page 14	10210-1 (10025)	17121, 17124 (17100)		49-501		42 0250	8731 (1050, 19281)		A 500 A 501	G 3444	630-2	
For machine parts and general use - page 16	10294-1 10297-1 (10083-1-3) (10084)	1629, 1630 (17200) (17204) (17210)	6323/1,2	49-311 49-312	663 7729	42 0250	8731	74219 (84018) (84019) (84023/7)	A 53 A 519	G 3445	2937 2938	
P R E S S U R E	For room temperature - page 22	10216-1	1629, 1630	3601	49-112	7287 49-210	42 0250	8731, (1050)	74219 (84023/7)	A 53	G 3454 G 3455	9329-1
	For elevated temperature (boiler) - page 26	10216-2	17175	3059/1,2 3602-1 3604-1	49-211 49-213	5462	42 0251	8731 TU14-3-190 TU14-3-460 4543,20072	74252 (84024)	A 106, A 192 A 209, A 210 A 213, A 335 A 556	G 3456 G 3458 G 3461 G 3462	9329-2
	Alloy fine grain steels - page 34	10216-3	17179									
	For low temperatures - page 36	10216-4	17173	3603	49-215	5949	42 0165			A333, A 334		9329-3
	For heat exchangers - page 48	10216-2 10216-4	17173 (17174) 17175 (17177) (28180, 28181)	3606	49-215 49-243 49-245	5462 5949	42 0165 42 0251	550 1060		A 179, A 178 A214 A333, A 334	G 3461 G 3462	6758 6759
For welding and threading - page 54	10224 10255	2440, 2441 (2442), 2460	1387	49-115	8863 6363	42 0250	3262	74220 74200	A 53 A 795	G 3452	65 559	
Line pipe - page 56	ISO 3183	2470-1/1629 2470-2/17172			7088				API 5L ISO 3183		3183	
Casing and Tubing - page 60									API 5 CT	ISO 11 960	11960	
Precision seamless cold drawn standard tubes - page 62	10305-1	2391-2	6323/1,4	49-310 49-312	7945	42 0260	8733 12132, 21729	74240 (74220)	A 519	G 3445	3304	
Cylinder tubes HPZ and HP - page 75 and 77	Precision tubes from steel St 52, E 355 Type HPZ for mechanical treatment, Type HP – “ready to use”											
For hydraulic lines - page 79	10305-4	2391-2c/2445-2	7416	49-330	7945	42 0260		74245	A 822	JOHS-102		
Injection tubes - page 74	Deliveries upon agreement only (ČSN 42 6718, DIN 73000, ISO 8535-1)											
Bearing tubes - page 88	ISO 683-17	17230	Deliveries according to agreed TDC									
Buttwelding fittings - page 92	10253-1,2	2609	1965-1	49-186		ŽP-05-05			A 234, A 420		3419	

## Seamless structural hollow sections (HSS)

Standards	Dimensional standards	Dimensional range	Dimensions				Straightness	Tube ends
			Tolerance D	Tolerance T	Lengths			
EN	10210-2	Table 5 / Page 40 • round profile • hot rolled • shape of the product HFCHS*	• $\pm 1\%$ • min $\pm 0,5$ mm • max $\pm 10$ mm • ovality $2\%$ • weight $\pm 6\%$ , max $8\%$	• $-10\%$ $-12,5\%$ for seamless profiles • + tolerance is limited by allowed weight	Indicative values: • $D < 60,3$ mm 5–6 m • $D \geq 60,3$ mm / $T < 7,1$ mm 5–6 m alebo 10–14 m • $D \geq 60,3$ mm / $T \geq 7,1$ mm 5–6 m Kinds: • random • fixed $\pm 500$ mm • exact $L < 6$ m $0 + 10$ mm * $L > 6$ m $0 + 15$ mm * • exact $L > 12$ m – tolerances upon agreement	Allowed $0,002L$ of whole length locally $3$ mm/m	• square cut ends • free from excessive burrs	
DIN	2448		• $\pm 1\%$ • min $\pm 0,5$ mm • weight $-8\% + 12\%$	$D < 130$ mm • $T \leq 2T_n - 10\% + 15\%$ • $2T_n < T < 4T_n - 10\% + 12,5\%$ • $T > 4T_n \pm 9\%$ $T_n$ - basic wall thickness according to DIN 2448 $D = 130-320$ mm • $T \leq 0,05D - 12,5\% + 17,5\%$ • $T > 0,05-0,11D \pm 12,5\%$ • $T > 0,11D \pm 10\%$				
NFA	49-501			• $D < 101,6$ mm $-12,5\% + 15\%$ • $D = 101,6-406,4$ mm $-12,5\% + 17,5\%$				
STN ČSN	42 5715 42 5716				See page 28			
GOST	8732	Table 6 / Page 42			See page 28			

\* HF production facilities to 12,7 m + 30 mm (50 mm), over 12,7 m + 100 mm

### Notes:

- C – carbon equivalent formula:  $CEV(IIW) = C + Mn/6 + (Cr + Mo + V)/5 + (Ni + Cu)/15$ .
- steel are weldable, specific conditions see individual standards.
- rate cold workability is set by mechanical steel properties and is definite with regulations.

- tubes according to EN 10210 fulfilled requirements for „CE“ marking
- tubes according to ASTM A500 (steel Grade A, B, C, D), ASTM A501 and JIS G3444 (steel STR290, STK400, STK 490, STK 500, STK540) upon agreement.
- possibility of hot dip zinc coating of tubes is necessary to discuss at inquiry
- HFCHC - Hot Finished Circular Hollow Section

### List of dimensional standards and technical delivery conditions standards

EN 10 025	Hot rolled products of structural steels. Part 1-6.
EN 10 210-1,2	Hot finished structural hollow sections of non-alloy and fine grain structural steel. Part 1: TDC. Part 2: Tolerances, dimensions and sectional properties. See also ISO 630-2 (TDC) and ISO 657-14 (DS).
EN 10266	Steel tubes, fittings and structural hollow sections - Symbols and definitions of terms for use in product standards. DIN 1629 - Seamless circular tubes of non-alloy steel with special quality requirements. TDC.
DIN 2448	Plain end seamless steel tubes. Dimensions.
DIN 17100	Steel for general structural purposes. Quality standard.
DIN 17121	Seamless structural steel circular tubes for structural engineering purposes.
DIN 17124	Seamless circular tubes of fine grain steel for engineering purposes.
NFA 49-501	Steel tubes. Seamless or welded hot finished structural hollow sections. Dimensions. TDC.
STN 42 0250	ČSN 42 0250 Hot formed seamless tubes from steel class 10 to 16. TDC.
STN 42 5715	ČSN 42 5715 Hot formed seamless steel tubes. Dimensions.
STN 42 5716	ČSN 42 5716 Hot formed seamless steel tubes with smaller tolerances. Dimensions.
GOST 8731	Seamless hot-formed steel pipes. TDC.
GOST 8732	Seamless hot-formed steel pipes. Dimensions.
JIS G3444	Carbon steel tubes for general structural purposes.

TDC standards	Name	Steel grade		Testing and certificates			Other TDC		
		Condition	Surface	Testing	Certificate	Marking	Surface protection	Packing	
10210-1 (10025) (10113)	S235 JRH S275 JOH S355 JOH S275 J2H S355 J2H S275 NH S275 NLH S355 NH S355 NLH S420 NLH S460 NH S460 NLH	Hot finished • as rolled Cold finished • normalized	adequate to production mode	option: (steels JRH, JOH) • non-specific • specific	10204 • 2.2 • 3.1 (3.2)	Bundle - label or Tubes - possibilities: • stenciling • stamping • attached label Data: • EN 10210 - Steel • manufacturer • specific inspection: - number - mark of the inspection representative	• without • oiled	bundle 300– 3500 kg	
	S275 NH S275 NLH S355 NH S355 NLH S420 NLH S460 NH S460 NLH	Hot finished • normalising rolled • normalized Cold finished • normalized		Specific (steels J2H, NH, NLH) tests (obligatory) only: • cast analysis • tensile test • impact test • tube surface (visual examination) • dimensions • NDT of weld	10204 • 3.1 • 3.2 see also page 7				
17 121 (17 100)	RSt 37-2 St 44-2 St 37-3 St 44-3 St 52-3	Hot finished • as rolled Cold finished • normalized		option:	50049 • 2.2 • 3.1 B,C	Compliance by CE and CE marking on tubes (CE marking upon agreement)			
17 124	StE 255 TStE 255 ESTE 255 StE 285 TStE 285 ESTE 285 StE 355 TStE 355 ESTE 355 StE 420 TStE 420 ESTE 420 StE 460 TStE 460 ESTE 460	Hot finished • normalising rolled • normalized Cold finished • normalized		• tensile test • tube surface • dimensions • impact test (T > 5 mm)	50049 • 3.1 B,C				
49 - 501	TU E235 TU E275 TU E355 TU E450 Kvalita 2,3,4	Hot finished • as rolled Cold finished • normalized		• cast analysis • tensile test • impact test (T > 5 mm) • tube surface	50049 • 3.1 A,B,C				
42 0250	11 353 11 453 11 503 11 523				See page 29				
8731	1050: 10, 20 19281: 09G25				See page 29				

### Steels grades, chemical composition and mechanical properties (steels according to ČSN, STN a GOST see pages 20–21)

Standards	Steel	Chemical composition [%]										Mechanical properties						
		C	Si	Mn	Pmax	Smax	Cr	Ni	Mo	Cu	Other	Re min MPa	Re min ksi	Rm min MPa	Rm max MPa	A5 min %		
<b>DIN</b>																		
17 121	RSt 37-2	max.0.17	-	-	0.050	0.050	-	-	-	-	N 0.009	235	-	340	470	-	26	
	St 44-2	max.0.21	-	-	0.050	0.050	-	-	-	-	N 0.009	275	-	410	540	-	22	
	St 44-3	max.0.20	-	-	0.040	0.040	-	-	-	-	Al min.0.020	275	-	410	540	-	22	
	St 52-3	max.0.22	-	-	0.040	0.040	-	-	-	-	Al min.0.020	355	-	490	630	-	22	
17 124	StE 255	max.0.18	max.0.40	0.50-1.30	0.035	0.030	max.0.30	max.0.30	max.0.08	max.0.20	Al min.0.020	255	-	360	480	-	25	
	TStE 255	max.0.16	max.0.40	0.50-1.30	0.030	0.025	max.0.30	max.0.30	max.0.08	max.0.20	Al min.0.020	255	-	360	480	-	25	
	ESTE 255	max.0.16	max.0.40	0.50-1.30	0.025	0.015	max.0.30	max.0.30	max.0.08	max.0.20	Al min.0.020	255	-	360	480	-	25	
	StE 285	max.0.18	max.0.40	0.60-1.40	0.035	0.030	max.0.30	max.0.30	max.0.08	max.0.20	Al min.0.020	285	-	390	510	-	24	
	TStE 285	max.0.16	max.0.40	0.60-1.40	0.030	0.025	max.0.30	max.0.30	max.0.08	max.0.20	Al min.0.020	285	-	390	510	-	24	
	ESTE 285	max.0.16	max.0.40	0.60-1.40	0.025	0.015	max.0.30	max.0.30	max.0.08	max.0.20	Al min.0.020	285	-	390	510	-	24	
	StE 355	max.0.20	0.10-0.50	0.90-1.65	0.035	0.030	max.0.30	max.0.30	max.0.08	max.0.20	Al min.0.020	355	-	490	630	-	22	
	TStE 355	max.0.18	0.10-0.50	0.90-1.65	0.030	0.025	max.0.30	max.0.30	max.0.08	max.0.20	Al min.0.020	355	-	490	630	-	22	
	ESTE 355	max.0.18	0.10-0.50	0.90-1.65	0.025	0.015	max.0.30	max.0.30	max.0.08	max.0.20	Al min.0.020	355	-	490	630	-	22	
	<b>NF A</b>																	
49-501	TU E235	max.0.20	-	-	0.040	0.040	-	-	-	-	-	235	-	340	480	-	25	
	TU E275	max.0.22	-	-	0.040	0.040	-	-	-	-	-	275	-	410	550	-	22	
	TU E355	max.0.24	max.0.60	max.1.60	0.040	0.040	-	-	-	-	-	355	-	490	640	-	21	
	TU E 450	max.0.25	max.0.60	max.1.60	0.040	0.040	-	-	-	-	-	450	-	550	720	-	19	
<b>EN</b>																		
10210-1	S 235 JRH	max.0.17	-	max.1.40	0.045	0.045	-	-	-	-	N 0.009	235	-	340	470	-	26	
	S 275 JOH	max.0.20	-	max.1.50	0.040	0.040	-	-	-	-	N 0.009	275	-	410	560	-	22	
	S 275 J2H	max.0.20	-	max.1.50	0.035	0.035	-	-	-	-	-	275	-	410	560	-	22	
	S 355 JOH	max.0.22	max.0.55	max.1.60	0.040	0.040	-	-	-	-	N 0.009	355	-	490	630	-	22	
	S 355 J2H	max.0.22	max.0.55	max.1.60	0.035	0.035	-	-	-	-	-	355	-	490	630	-	22	
	S 275 NH	max.0.20	max.0.40	0.50-1.40	0.035	0.030	max.0.30	max.0.30	max.0.10	max.0.35	V max.0.05	275	-	370	510	-	24	
	S 275 NLH	max.0.20	max.0.40	0.50-1.40	0.030	0.025	max.0.30	max.0.30	max.0.10	max.0.35	V max.0.12	275	-	370	510	-	24	
	S 355 NH	max.0.20	max.0.50	0.90-1.65	0.035	0.030	max.0.30	max.0.30	max.0.10	max.0.35	V max.0.12	355	-	470	630	-	22	
	S 355 NLH	max.0.18	max.0.50	0.90-1.65	0.030	0.025	max.0.30	max.0.30	max.0.10	max.0.35	V max.0.12	355	-	470	630	-	22	
	S420 NH	max.0.22	max.0.60	1.00-1.70	0.035	0.030	max.0.30	max.0.30	max.0.80	max.0.10	max.0.70	V max.0.20	420	-	520	680	-	19
	S420 NLH	max.0.22	max.0.60	1.00-1.70	0.030	0.025	max.0.30	max.0.30	max.0.80	max.0.10	max.0.70	Al min.0.020	420	-	520	680	-	19
	S 460 NH	max.0.20	max.0.60	1.00-1.70	0.035	0.030	max.0.30	max.0.30	max.0.80	max.0.10	max.0.70	Nb max.0.05	460	-	550	720	-	17
	S 460 NLH	max.0.20	max.0.60	1.00-1.70	0.030	0.025	max.0.30	max.0.30	max.0.80	max.0.10	max.0.70	Ti max.0.03	460	-	550	720	-	17

Note: Steel grades marking according to EN see page 105

## Seamless steel tubes for mechanical and general engineering purpose

Standards	Dimensional standards	Dimensional range	Dimensions				
			Tolerance D	Tolerance T	Lengths	Straightness	Tube ends
EN	10294-1 (upon agreement) **	<ul style="list-style-type: none"> <li>tubes from mill are not machining operated</li> <li>in preference as precision tubes</li> <li>dimension D x d (up to D = 100mm)</li> </ul> Table 5 / Page 40	D ≤ 75 mm ±0,5 mm D = 75–180 mm ±0,75 % D > 180 mm ± 1%	D ≤ 180mm, T ≤ 15 mm ±12,5 % min ±0,4 mm	<ul style="list-style-type: none"> <li>random</li> <li>exact upon agreement</li> </ul>	<ul style="list-style-type: none"> <li>0,001.L</li> <li>locally (1mm/m)</li> <li>deliveries in agreement</li> </ul>	<ul style="list-style-type: none"> <li>square cut ends</li> <li>free from excessive burrs</li> </ul>
	10297-1 (10220)  10305-1 (upon agreement)	Table 25 / Page 69 Table 26 / Page 70	D ≤ 219,1 mm ±1 % min ±0,5 mm  See page 62–66 (Cold formed precise)	D ≤ 219,1 mm ±12,5 % min ±0,4 mm  See page 62 - 65 (Cold formed precise)	<ul style="list-style-type: none"> <li>random</li> <li>exact</li> <li>L &lt; 6 m 0 +10 mm *</li> <li>L = 6–12 m 0 +15 mm *</li> <li>L &gt; 12 m upon agreement</li> </ul>	D > 33,7 mm 0,0015.L	
DIN	2448	Table 5 / Page 40	See page 22				
	2448 (2391)						
BS	6323/3		±1% min ±0,5 mm	≤ 3% D ±15 % > 3% D -12,5 % +15 %	<ul style="list-style-type: none"> <li>random</li> <li>exact *</li> <li>L &lt; 6 m 0 +10 mm</li> <li>L &gt; 6 m 0 +15 mm</li> </ul>		<ul style="list-style-type: none"> <li>square cut ends</li> <li>free from excessive burrs</li> </ul>

\* HF production facilities to 12,7 m + 30 mm (50 mm), over 12,7 m + 100 mm

### List of dimensional standards and technical delivery conditions standards

- EN 10 083 Steels for quenching and tempering. Part 1: General TDC. Part 2: TDC for non-alloy steels. Part 3: TDC for alloy steels.
- EN 10 084 Case hardening steel. TDC.
- EN 10 216 - 1 Seamless steel tubes for pressure purposes. TDC.  
Part 1: Non-alloy steel tubes with specific room temperature properties.
- EN 10 294 - 1. Hollow bars for machining. Part 1: Non-alloy and alloy steel.
- EN 10 297 - 1 Seamless circular steel tubes for mechanical and general engineering purposes.  
Part 1: Non-alloy and alloy steel tubes.
- DIN 1629 Seamless circular tubes of non-alloy steel with special quality requirements.TDC.
- DIN 1630 Seamless circular tubes of non-alloy steel with very high quality requirements. TDC.
- DIN 2448 Seamless tubes. Dimensions.
- DIN 17200 Steels for quenching and tempering. TDC.
- DIN 17204 Seamless circular tubes of steel for quenching and tempering. TDC.
- DIN 17210 Case hardening steels. TDC.
- BS 6323 Specification for seamless and welded steel tubes for automobile, mechanical and general engineering purposes.  
Part 1: General requirements. Part 3: Specific requirements for hot finished seamless steel tubes.
- ISO 2937 Plain end seamless steel tubes for mechanical application.
- ISO 2938 Hollow steel bars for machining.



TDC standards	Steel grade			Testing and certificates		Other TDC		
	Name	Condition	Surface	Testing	Certificate	Marking	Surface protection	Packing
10294-1	E355 E355 J2 E420 J2* E 470* *steel type 20MnV6	+ AR + N + N + AR Cold finished • + N or + SR	visually missless adequate to production mode.	• cast analysis • tensile test • impact test (if possible) • dimensions • visual	Specific: EN 10204 3.1	Longitudinally on tube • paint stenciling • die stamping • label on tube Label on bundle (D < 45 mm) Data: • producer • standard EN • steel grade • delivery condition • D x d (EN 10294 - 1) • +H and cast number (EN 10297-1) • inspector	• without • upon agreement	bundle 300– 3500 kg
10297-1	E235 E275 E315 E355  E470 E275K2 E355K2 E460K2 E420J2 C22E C35E C45E C60E 38Mn6 41Cr4 25CrMo4 30CrMo4 34CrMo4 42CrMo4 C10E C15E C15R 20NiCrMo2-2 16MnCr5	+ AR, + N + AR, + N + AR, + N + AR, + N + AR + N + N + N + N + N + N + N + N + N + N + QT (+ N) + QT (+ N) + QT (+ N) + QT (+ N) + QT (+ N) + N (+A) + N (+A) + N (+A) + N (+A) + N		Mandatory: • cast analysis • tensile test • impact test ((if possible)) • dimensions • visual • material identification (for alloyed steel)  Optional: • upon agreement Table 17 of standard	Non-specific: EN 10204 2.1 (2.2) Specific: EN 10204 3.1 (3.2)  (See also page 7)			
EN 10083-2 - C steel C 22, 35, 40, 45, 55, 60; CxyE and CxyR - 22, 35, 40, 45, 50, 55, 60 and 28Mn6 EN 10083-3 - Alloy steels (see overview page 21 and comparison of steels) EN 10084 - CxyE a CxyR - 10, 15, 16 and alloy steels These standards are presented only informatory. Steel tubes produced from steels from these standards are included in EN 10297-1								
1629 1630	See page 23							
17200 17204  17210	Steel types: C22 Ck22 Cm22 C10*	Hot finished - U • as rolled Cold finished • +NBK, +BK		• visual • dimensions • other test upon agreement	DIN 50049 2.2, 3.1.B	• each tube • small diameter by label		
6323/1,3	HFS 3 (360) HFS 4 (410) HFS 5 (490) HFS 8 (540)	Hot finished • as rolled		• tensile test • flattening • impact test • drift expanding • hydrotest or NDT upon agreement	Compliance with standard certificate		• without • upon agreement	

Steel with boron content (kind 20MnB5) upon agreement.

\* List of steel – see table of chemical composition at pages 20, 21. This group of tubes can be delivered also according to DS for exact tubes (cold drawn) – see page 60 and other.

\*\* Tubes are not mechanically worked. D tolerance upon agreement.

#### Steel designation according to EN:

- steel for tubes for mechanical treatment:

steel E355 + AR, E 355 + N

E – steel for machine parts, 355 – minimum yield strength in N/mm<sup>2</sup>, +AR – heat treatment is not required,

+N – normalising annealed or formed

steel 20MnV6

steel designated by chemical composition – guaranteed mean C content 0,20%, guaranteed content Mn and V

+AR – heat treatment is not required, +N – normalising annealed or formed

- steel for machine parts:

steel without heat treatment after mechanical treatment

non-alloy steel E 235, E275, E315, E355

Condition +AR or +N

steel with specific impact qualities (fine-grain) E275K2, E355K2

K2 – guaranteed characteristic of impact energy 40 J (K) by temperature –20 °C

steel with heat treatment after mechanical treatment

steel C22E

C – steel with carbon content 0,22%, E – reference to maximum checked content of S and P

steel 38Mn6

– guaranteed mean C content and guaranteed Mn content

**Note:** Steel grades marking according to EN - see page 105

## ▶▶▶ Seamless steel tubes for mechanical and general engineering purpose

Standards	Dimensional standards	Dimensional range	Dimensions				Straightness	Tube ends
			Tolerance D	Tolerance T	Lengths			
NF A	49-311	Table 5/Page 40	±1 % min ±0,5 mm  Weight -8 % +10 %	T < 20 mm ±15 % min ±0,5 mm		• random • exact		• square cut ends • free from excessive burrs
	49-312							
UNI	4991 (ISO 4200)		Hot finished: D ≤ 51 mm ±0,5 mm D = 51-419 mm ±1% Weight ±10% Cold finished: D ≤ 25 mm ±0,25 mm D = 25-51 mm ±0,35 mm D = 51-168,3 mm ±0,75 mm Weight -8 % +10 % ±1 % min ± 0,5 mm Weight ±10 %	-15 % + non-specific (limited by weight)  T ≤ 7mm ±12% min ±0,10mm T > 7mm -10 +12 %  T/D ≤ 3 % ±15 % T/D > 3 % ±12,5 % (do D = 168,3 mm)		• random • exact L < 6 m 0 +10 mm * L > 6 m 0 +15 mm *	1,5 mm/m	
	7729							
STN ČSN	42 5715 42 5716					See page 24		
GOST	8732	Table 6/Page 42				See page 28		
PN-H	74219					See page 24		
ASTM ASME	A53* SA-53*	Table 7/Page 44	NPS ≤ 1½ ±¼ inch (±0,4 mm) NPS ≥ 2 ±1 % Weight ±10 %	-12,5 %		• random 6 m ±500 mm • exact 6 m - 0 +15 mm *	visually straight	• square cut ends • plain, not threadet • NPS ≤ 1,5 (DN 40/48,3 mm) option of the manufacturer • NPS ≥ 2 (DN 50/60,3 mm) T=Std, XS, less than 0,5 inch/12,7 mm beveled (s. 98) T > 0,5 inch and XXS – plain and square cut
	A519	Table 9/Page 46 Table 28/Page 71 Table 30/Page 72	Hot finished: D ≤ 76,17 mm ±0,51 mm D = 76,2-114,2 mm ±0,64 mm D = 114,3-152,3 mm ±0,79 mm Cold finished: Table 8 of standard	Table 7 of standard  Table 9 of standard				
JIS	G3445	Table 12/Page 47				See page 24		

\* HF production facilities to 12,7 m + 30 mm (50 mm), over 12,7 m + 100 mm

\* Ends preparing is valid for ASTM A53, for A519 as NF A.

### List of dimensional standards and technical delivery conditions standards

STN 42 0250	ČSN 42 0250	Hot formed seamless tubes from steel class 10 to 16. TDC.
STN 42 5715	ČSN 42 5715	Hot formed seamless steel tubes. Dimensions.
STN 42 5716	ČSN 42 5716	Hot formed seamless steel tubes with smaller tolerances. Dimensions.
ASTM A53		Pipe, steel, black and hot-dipped, zinc-coated, welded and seamless.
ASTM A519		Seamless carbon and alloy steel mechanical tubing.
ASTM A530		General requirements for specialized carbon and alloy steel pipe.
UNI ISO 4200		Plain end steel tubes, welded and seamless. General dimensions and masses per unit length.
UNI 663		Unalloyed seamless steel tubes. Plain end tubes for general purposes.
UNI 4991		Standard plain end seamles and welded tubes. Dimensions.
UNI 7729		Unalloyed seamless steel tubes - plain end tubes for mechanical application.
NFA 49-311		Seamless steel tubes for mechanical application. Dimensions. TDC.
NFA 49-312		Seamless steel tubes with improved mechinability for mechanical machined parts.
GOST 1050		Rolled material from standard C- steel grades
GOST 8731		Seamless hot-formed steel pipes. TDC.
GOST 8732		Seamless hot-formed steel pipes. Dimensions.
GOST 19281		Rolled material from high strength steel
JIS G 3445		Carbon steel tubes for machine structural purposes.
PN-H 74219		Hot rolled seamless steel tubes.
PN-H 84018		Low-alloy steel with higher properties.
PN-H 84019		Carbon steel for heat treatment.
PN-H 84023/7		Steel for higher purposes. Steel for tubes.

TDC standards	Name	Steel grade Condition	Surface	Testing and certificates		Other TDC		
				Testing	Certificate	Marking	Surface protection	Packing
49-311	TU 37-b TU 52-b TU 56-b TU XC35	Hot finished • as rolled		• tensile test • cast analysis • other tests upon agreement	Upon agreement	• Longitudinally on tube • Label on bundle	• without • upon agreement	bundle 300– 3500 kg
49-312	S 470M S 450MG2	Hot finished • as rolled • normalized						
663	Fe 35-1 Fe 45-1 Fe 52-1 Fe 55-1 Fe 35-2 Fe 45-2 Fe 52-2 Fe 55-2	Hot finished • as rolled Cold finished • normalized		• hydrotest • other tests upon agreement				
7729	Fe 360 Fe 510 Fe 540			• visual • tensile test • dimensions		• producer's logo • steel grade • standard		
42 0250				Data – see page 25				
8731	→	steel 1050: 10, 20, 35, 45; 19281: 09G2S		Data – see page 29				
74219	→	steel 84018: 18G2, 18G2A; 84019: 10, 20, 35, 45, 55; 84023/7: R35, R45, R55 (chemical composition see also page 67)		Data – see page 25				
A53/A530 SA53/SA 530	Grade A Grade B	Hot finished • as rolled Dimensions 1/8– 3/8 (DN 6 - 10) cold finished and thereafter heat treated	• adequate to production mode • upon agreement insulation	• product analysis • tensile test • impact test (NPS ≤ 2 inch) • flattening • leakage – optional: - NDT (NDE) E213, E309, E570 - hydrostatic pressure, values see page 104		Tube or bundle: Data: • producer • seamless • steel grade • standard size • length • cast number method of testing NPS < 11/2 – label	at non insulated tubes upon agreement	according to A700
A519	Steel grades see in chemical composition tables	Hot finished (HF) Cold finished (CW) • A (annealed) • N(normalized) • SR (stress relieved) • QT (quench. and temp.)		• product analysis • tensile test (upon agreement) • hardness (upon agreement) • drift expanding (upon agreement) • NDT (upon agreement)				
G3445	Steel grades see in chemical composition tables	Seamless tubes: S Hot finished: H Cold finished: C • condition according to agreement		• product analysis • tensile test • impact test • flattening • hydrotest or NDT upon agreement		Tube or bundle: • steel • method (SH, SC) • dimension • producer		

# Steels for tubes for mechanical and general engineering

Standards	Steel	Chemical composition [%]										Mechanical properties						
		C	Si	Mn	Pmax	Smax	Cr	Ni	Mo	Cu	Other	Re min MPa	Re min ksi	Rm min MPa	Rm max MPa	min ksi	A5 min %	
<b>STN, ČSN</b>																		
	11 353	max.0,18			0,050	0,050								235		340	440	25
	11 453	max.0,24			0,050	0,050								265		441	539	21
	11 503	max.0,18	max.0,55	max.1,60	0,035	0,035	max.0,30	max.0,30			max.0,30	Al min.0,015 Nb 0,015-0,08	355		490	630	22	
	11 523	max.0,22	max.0,55	max.1,60	0,035	0,035						Al min.0,015	353		510	628	23	
	11 550	max.0,40			0,050	0,050							315		540	640	17	
	11 650	max.0,55			0,050	0,050							365		640	735	12	
	12 040	0,32-0,40	0,15-0,40	0,50-0,80	0,040	0,040	max.0,25	max.0,30			max.0,30		295			530	18	
	12 050	0,42-0,50	0,17-0,37	0,50-0,80	0,040	0,040	max.0,25	max.0,30			max.0,30		325			590	17	
	12 060	0,52-0,60	0,15-0,40	0,50-0,80	0,040	0,040	max.0,25	max.0,30			max.0,30		375			640	13	
<b>ASTM</b>																		
A 53	GradeA	0,25		0,95	0,050	0,045	0,40	0,40	0,15	0,40	V 0,08		205	30	330		48	
	GradeB	0,30		1,20	0,050	0,045	0,40	0,40	0,15	0,40	V 0,08		240	35	415	60		
A 519	MT 1010	0,05-0,15		0,30-0,60	0,040	0,050												
	MT 1015	0,10-0,20		0,30-0,60	0,040	0,050												
	MT X 1015	0,10-0,20		0,60-0,90	0,040	0,050												
	MT 1020	0,15-0,25		0,30-0,60	0,040	0,050												
	MT X 1020	0,15-0,25		0,70-1,00	0,040	0,050												
	1008	max.0,10		0,30-0,50	0,040	0,050												
	1010	0,08-0,13		0,30-0,60	0,040	0,050												
	1012	0,10-0,15		0,30-0,60	0,040	0,050												
	1015	0,13-0,18		0,30-0,60	0,040	0,050												
	1016	0,13-0,18		0,60-0,90	0,040	0,050												
	1017	0,15-0,20		0,30-0,60	0,040	0,050												
	1018	0,15-0,20		0,60-0,90	0,040	0,050												
	1019	0,15-0,20		0,70-1,00	0,040	0,050												
	1020	0,18-0,23		0,30-0,60	0,040	0,050							221	32	345	50	25	
	1021	0,18-0,23		0,60-0,90	0,040	0,050												
	1022	0,18-0,23		0,70-1,00	0,040	0,050												
	1025	0,22-0,28		0,30-0,60	0,040	0,050							241	35	379	55	25	
	1026	0,22-0,28		0,60-0,90	0,040	0,050												
	1030	0,28-0,34		0,60-0,90	0,040	0,050												
	1035	0,32-0,37		0,60-0,90	0,040	0,050							276	40	448	65	20	
	1040	0,37-0,44		0,60-0,90	0,040	0,050												
	1045	0,43-0,50		0,60-0,90	0,040	0,050							310	45	517	75	15	
	1050	0,48-0,55		0,60-0,90	0,040	0,050							345	50	552	80	10	
	1518	0,15-0,21		1,10-1,40	0,040	0,050												
	1524	0,19-0,25		1,35-1,65	0,040	0,050												
	1541	0,36-0,44		1,35-1,65	0,040	0,050												
<b>DIN</b>																		
1629	St 37.0	max.0,17			0,040	0,040							235		350	480	25	
	St 44.0	max.0,21			0,040	0,040							275		420	550	21	
	St 52.0	max.0,22			0,040	0,035						Al min.0,020	355		500	650	21	
1630	St 37.4	max.0,17	max.0,35	min.0,35	0,040	0,040						Al min.0,020	235		350	480	25	
	St 44.4	max.0,20	max.0,35	min.0,40	0,040	0,040						Al min.0,020	275		420	550	21	
	St 52.4	max.0,22	max.0,55	max.1,60	0,040	0,035						Al min.0,020	355		500	650	21	
17204	C22	0,17-0,24	max.0,40	0,30-0,60	0,045	0,045							260		420	550	21	
	Ck22	0,17-0,24	max.0,40	0,30-0,60	0,035	0,035							260		420	550	21	
	Cm22	0,17-0,24	max.0,40	0,30-0,60	0,035	0,035							260		420	550	21	
	C35	0,32-0,39	max.0,40	0,50-0,80	0,045	0,045							300		520	670	17	
	Ck35	0,32-0,39	max.0,40	0,50-0,80	0,035	0,035							300		520	670	17	
	Cm35	0,32-0,39	max.0,40	0,50-0,80	0,035	0,035							300		520	670	17	
	C45	0,42-0,50	max.0,40	0,50-0,80	0,045	0,045							350		610	760	16	
	Ck45	0,42-0,50	max.0,40	0,50-0,80	0,035	0,035							350		610	760	16	
	Cm45	0,42-0,50	max.0,40	0,50-0,80	0,035	0,035							350		610	760	16	
	C55	0,52-0,60	max.0,40	0,60-0,90	0,045	0,045							370		670	820	14	
	Ck55	0,52-0,60	max.0,40	0,60-0,90	0,035	0,035							370		670	820	14	
	Cm55	0,52-0,60	max.0,40	0,60-0,90	0,035	0,035							370		670	820	14	
17210	C10	0,07-0,13	max.0,40	0,30-0,60	0,045	0,045												
	Ck10	0,07-0,13	max.0,40	0,30-0,60	0,035	0,035												
	C15	0,12-0,18	max.0,40	0,30-0,60	0,045	0,045												
	Ck15	0,12-0,18	max.0,40	0,30-0,60	0,035	0,035												
	Cm15	0,12-0,18	max.0,40	0,30-0,60	0,035	0,035												
	16MnCr5	0,14-0,19	max.0,40	1,00-1,30	0,035	0,035	0,80-1,10											
<b>BS</b>																		
6323/3	HFS 3	max.0,20	max.0,35	max.0,90	0,050	0,050							215		360		24	
	HFS 4	max.0,25	max.0,35	max.1,20	0,050	0,050							235		410		22	
	HFS 5	max.0,23	max.0,50	max.1,50	0,050	0,050							340		490		20	
	HFS 8	0,40-0,55	max.0,35	0,50-0,90	0,050	0,050							340		540		18	
<b>UNI</b>																		
663	Fe 35-1	max.0,18	-	-	0,045	0,045							240		350	450	25	
	Fe 45-1	max.0,22	-	-	0,045	0,045							260		450	550	21	
	Fe 55-1	max.0,36	-	-	0,045	0,045							340		550	650	17	
	Fe 35-2	max.0,17	0,10-0,35	min.0,40	0,035	0,035							240		350	450	28	
	Fe 45-2	max.0,22	0,10-0,35	min.0,50	0,035	0,035							260		450	550	23	
	Fe 55-2	max.0,36	0,10-0,35	min.0,50	0,035	0,035							340		550	650	18	
7729	Fe 360	max.0,17	max.0,36	0,40-0,80	0,045	0,045							215		360	480	24	
	Fe 510	max.0,20	max.0,50	min.1,50	0,040	0,040							355		510	660	20	
	Fe 540	0,32-0,38	0,15-0,40	0,50-0,80	0,035	0,035							275		540	660	20	
<b>NF A</b>																		
49-311	TU 37-b	max.0,20	max.0,40	max.0,85	0,045	0,045							220		360		20	
	TU 52-b	max.0,22	max.0,55	max.1,60	0,045	0,045							345		510		17	
	TU XC35	0,30-0,40	0,10-0,45	0,40-0,90	0,040	0,040							320		540		16	
49-312	S470M	0,15-0,22	max.0,50	1,00-1,70	0,030	0,040					max.0,30	V 0,08-0,15	470		620		18	
	S450MG2	0,15-0,22	max.0,50	1,00-1,70	0,030	0,040					max.0,30	V 0,08-0,15	450		550	720	22	

In steels of type Cm 22 is content of S 0,020-0,035 %. In steels of type C 22R is content of S 0,020-0,040 %.

\* The total composition for elements Cr, Ni, Mo, Cu, V shall not exceed 1,00%.

Standards	Steel	Chemical composition [%]										Mechanical properties				
		C	Si	Mn	Pmax	Smax	Cr	Ni	Mo	Cu	Other	Re min MPa	Re min ksi	Rm min MPa	Rm min ksi	A5 min %
<b>EN</b>																
10083-2	(C22R)	0,17-0,24	max,040	0,40-0,70	0,035	0,040	max, 0,40	max, 0,40	max, 0,10			240	430		24	
	C25E	0,22-0,29	max,040	0,40-0,70	0,035	0,035	max, 0,40	max, 0,40	max, 0,10			260	470		22	
	(C25R)	0,22-0,29	max,040	0,40-0,70	0,035	0,040	max, 0,40	max, 0,40	max, 0,10			260	470		22	
	C30E	0,27-0,34	max,040	0,50-0,80	0,035	0,035	max, 0,40	max, 0,40	max, 0,10			280	510		20	
	(C30R)	0,27-0,34	max,040	0,50-0,80	0,035	0,040	max, 0,40	max, 0,40	max, 0,10			280	510		20	
	(C35R)	0,32-0,39	max,040	0,50-0,80	0,035	0,040	max, 0,40	max, 0,40	max, 0,10			300	550		18	
	C40E	0,37-0,44	max,040	0,50-0,80	0,035	0,035	max, 0,40	max, 0,40	max, 0,10			320	580		16	
	(C40R)	0,37-0,44	max,040	0,50-0,80	0,035	0,040	max, 0,40	max, 0,40	max, 0,10			320	580		16	
	(C45R)	0,42-0,50	max,040	0,50-0,80	0,035	0,040	max, 0,40	max, 0,40	max, 0,10			340	620		14	
	C50E	0,47-0,55	max,040	0,60-0,90	0,035	0,035	max, 0,40	max, 0,40	max, 0,10			355	650		12	
	(C50R)	0,47-0,55	max,040	0,60-0,90	0,035	0,040	max, 0,40	max, 0,40	max, 0,10			355	650		12	
	C55E	0,52-0,60	max,040	0,60-0,90	0,035	0,035	max, 0,40	max, 0,40	max, 0,10			370	680		11	
	(C55R)	0,52-0,60	max,040	0,60-0,90	0,035	0,040	max, 0,40	max, 0,40	max, 0,10			370	680		11	
	28Mn6	0,25 - 0,32	max,040	1,30 - 1,65	0,030	0,035	max, 0,40	max, 0,40	max, 0,10							
	C22	0,17-0,24	max,040	0,40-0,70	0,045	0,045	max, 0,40	max, 0,40	max, 0,10			240	430		24	
	C25	0,22-0,29	max,040	0,40-0,70	0,045	0,045	max, 0,40	max, 0,40	max, 0,10			260	470		22	
	C30	0,27-0,34	max,040	0,50-0,80	0,045	0,045	max, 0,40	max, 0,40	max, 0,10			280	510		20	
	C35	0,32-0,39	max,040	0,50-0,80	0,045	0,045	max, 0,40	max, 0,40	max, 0,10			300	550		18	
C40	0,37-0,44	max,040	0,50-0,80	0,045	0,045	max, 0,40	max, 0,40	max, 0,10			320	580		16		
C45	0,42-0,50	max,040	0,50-0,80	0,045	0,045	max, 0,40	max, 0,40	max, 0,10			340	620		14		
C50	0,47-0,55	max,040	0,60-0,90	0,045	0,045	max, 0,40	max, 0,40	max, 0,10			355	650		12		
C55	0,52-0,60	max,040	0,60-0,90	0,045	0,045	max, 0,40	max, 0,40	max, 0,10			370	680		11		
10084	(C10R)	0,07-0,13	max,040	0,30-0,60	0,035	0,040										
	C16E	0,12-0,18	max,040	0,60-0,90	0,035	0,035										
	(C16R)	0,12-0,18	max,040	0,60-0,90	0,035	0,040										
10294-1	16MnCr5	0,14-0,19	max,040	1,00-1,30	0,035	0,035	0,80-1,10									
	E355+AR	max, 0,22	max, 0,50	max, 1,50	0,045	0,050	max, 0,30	max, 0,40	max, 0,08	max, 0,30	V max,0,10	355	490		18	
	E355+N	max, 0,22	max, 0,50	max, 1,50	0,045	0,050	max, 0,30	max, 0,40	max, 0,08	max, 0,30	V max,0,10	355	490		20	
	20MnV6+AR	0,16-0,22	0,10-0,50	1,30-1,70	0,045	0,050	max, 0,30	max, 0,40	max, 0,08	max, 0,30	V 0,08-0,15	470	650		17	
10297-1	20MnV6+N	0,16-0,22	0,10-0,50	1,30-1,70	0,045	0,050	max, 0,30	max, 0,40	max, 0,08	max, 0,30	V 0,08-0,15	420	600		19	
	C22E	0,17-0,24	max,040	0,40-0,70	0,035	0,035	max, 0,40	max, 0,40	max, 0,10			240	430		24	
	C35E	0,32-0,39	max,040	0,50-0,80	0,035	0,035	max, 0,40	max, 0,40	max, 0,10			300	550		18	
	C45E	0,42-0,50	max,040	0,50-0,80	0,035	0,035	max, 0,40	max, 0,40	max, 0,10			340	620		14	
	C10E	0,07-0,13	max,040	0,30-0,60	0,035	0,035										
	C15E	0,12-0,18	max,040	0,30-0,60	0,035	0,035										
	(C15R)	0,12-0,18	max,040	0,30-0,60	0,035	0,040										
	E235	max, 0,17	max, 0,35	max, 1,20	0,030	0,035						235	360		25	
	E275	max, 0,21	max, 0,35	max, 1,40	0,030	0,035						275	410		22	
	E315	max, 0,21	max, 0,30	max, 1,50	0,030	0,035						315	450		21	
	E355	max, 0,22	max, 0,55	max, 1,60	0,030	0,035						355	490		20	
	E275K2	max,0,20	max,0,40	0,50-1,40	0,030	0,030	max,0,30	0,30	max,0,10	max,0,35	V max,0,05 Ti max,0,03 Al min, 0,02	275	410		22	
	E355K2	max,0,20	max,0,50	0,90-1,65	0,030	0,030	max,0,30	0,50	max,0,10	max,0,35	V max, 0,05 Ti max,0,05 Al min, 0,02	355	490		20	
	C60E	0,57 - 0,65	max, 0,40	0,60 - 0,90	0,035	0,035						390	710		10	
	38Mn6	0,34-0,42	0,15-0,30	1,40-1,65	0,035	0,035						400	670		14	
	25CrMo4	0,22 - 0,29	max, 0,40	0,60 - 0,90	0,035	0,035	0,90 - 1,20			0,15 - 0,30						
	34CrMo4	0,30 - 0,37	max, 0,40	0,60 - 0,90	0,035	0,035	0,90 - 1,20			0,15 - 0,30						
42CrMo4	0,38 - 0,45	max, 0,40	0,60 - 0,90	0,035	0,035	0,90 - 1,20			0,15 - 0,30							
20NiCrMo2-2	0,17 - 0,23	max, 0,40	0,65 - 0,95	0,035	0,035	0,35 - 0,70	0,40 - 0,70	0,15 - 0,25								
<b>GOST</b>																
1050	10	0,07-0,14	0,17-0,37	0,35-0,65			max,0,15					205	330		31	
	20	0,17-0,24	0,17-0,37	0,35-0,65			max,0,25					245	410		25	
	35	0,32-0,40	0,17-0,37	0,50-0,80			max,0,25					315	530		20	
	45	0,42-0,50	0,17-0,37	0,50-0,80			max,0,25					355	600		16	
19281	09G2S	max,0,12	0,50-0,80	1,30-1,70			max,0,30	max,0,30		max,0,30		345	490		21	
<b>JIS</b>																
G 3445	STKM 11A	max,0,12	max,0,35	max,0,60	0,040	0,040							290		35	
	STKM 12A	max,0,20	max,0,35	max,0,60	0,040	0,040						175	340		35	
	STKM 12B	max,0,20	max,0,35	max,0,60	0,040	0,040						275	390		25	
	STKM 12C	max,0,20	max,0,35	max,0,60	0,040	0,040						355	470		20	
	STKM 13A	max,0,25	max,0,35	0,30-0,90	0,040	0,040						215	370		30	
	STKM 13B	max,0,25	max,0,35	0,30-0,90	0,040	0,040						305	440		20	
	STKM 13C	max,0,25	max,0,35	0,30-0,90	0,040	0,040						380	510		15	
	STKM 14A	max,0,30	max,0,35	0,30-1,00	0,040	0,040						245	410		25	
	STKM 14B	max,0,30	max,0,35	0,30-1,00	0,040	0,040						355	500		15	
	STKM 14C	max,0,30	max,0,35	0,30-1,00	0,040	0,040						410	550		15	
	STKM 15A	0,25-0,35	max,0,35	0,30-1,00	0,040	0,040						275	470		22	
	STKM 15C	0,25-0,35	max,0,35	0,30-1,00	0,040	0,040						430	580		12	
	STKM 16A	0,35-0,45	max,0,40	0,40-1,00	0,040	0,040						325	510		20	
	STKM 16C	0,35-0,45	max,0,40	0,40-1,00	0,040	0,040						460	620		12	
	STKM 17A	0,45-0,55	max,0,40	0,40-1,00	0,040	0,040						345	550		20	
	STKM 17C	0,45-0,55	max,0,40	0,40-1,00	0,040	0,040						480	650		10	
	STKM 18A	max,0,18	max,0,55	max,1,50	0,040	0,040						275	440		25	
	STKM 18B	max,0,18	max,0,55	max,1,50	0,040	0,040						315	490		23	
	STKM 18C	max,0,18	max,0,55	max,1,50	0,040	0,040						380	510		15	
	STKM 19A	max,0,25	max,0,55	max,1,50	0,040	0,040						315	490		23	
STKM 19C	max,0,25	max,0,55	max,1,50	0,040	0,040						410	550		15		
STKM 20A	max,0,25	max,0,55	max,1,60	0,040	0,040					V max,0,15	390	540		23		
<b>PN-H</b>																
84019	10	0,07-0,14	0,15-0,40	0,35-0,65	0,040	0,040	max,0,30	max,0,30	max,0,10	max,0,30						
	20	0,17-0,24	0,15-0,40	0,35-0,65	0,040	0,040										
	35	0,32-0,39	0,10-0,40	0,50-0,80	0,040	0,040										
	45	0,42-0,50	0,10-0,40	0,50-0,80	0,040	0,040										

Steel 20MnV6+AR = E470, 20MnV6+N = E420J2, 20MnV6+QT = E590K2 (see also pages 115 and 116).

Alloy steel in EN 10083-3 see pages 120-121. Steel for mechanical tubes according to PN-H see also page 67.



## Seamless steel tubes for pressure equipments for room temperatures

Standards	Dimensional standards	Dimensional range	Dimensions				
			Tolerance D	Tolerance T	Lengths	Straightness	Tube ends
EN	10216-1  10305-1 (upon agreement)	Table 5/Page 40  Table 25/Page 69	D ≤ 219,1 mm ± 1 % min ± 0,5 mm  See page 62–65 (Cold formed precise)	D ≤ 219,1 mm ± 12,5 % min ± 0,4 mm  See page 62–65 (Cold formed precise)	Kinds: • random • fixed ± 500 mm • exact Indicative values: • D < 60,3 mm 5–6 m • D ≥ 60,3 mm / T < 7,1 mm 5–6 m or 10–14 m • D ≥ 60,3 mm / T ≥ 7,1 mm 5–6 m • longer upon agreement Precise length tolerances: • L < 6 m 0 + 10 mm * • L = 6–12 m 0 + 15 mm * • L > 12 m 0 + upon agreement	Allowed 0,0015.L for tube calculation to 1 m max. 3 mm	• square cut ends • free from excessive burrs • option: with beveled ends (see page 98)
DIN	2448  2391-1 (upon agreement)	Table 5/Page 40  Table 25/Page 69	D ≤ 100 mm ± 1 % min ± 0,5 mm D = 100–200 mm ± 1 %  See page 62–65 (Cold finished precise)	D < 130 mm • T ≤ 2Tn -10 % + 15 % • 2Tn < T < 4Tn -10 % + 12,5 % • T > 4Tn ± 9 % Tn – basic wall thickness according to DIN 2448  D = 130–320 mm • T ≤ 0,05D -12,5 % + 17,5 % • T > 0,05–0,11D ± 12,5 % • T > 0,11D ± 10 %  See page 60–67 (Cold finished precise)		Visually straight	• square cut ends • free from excessive burrs • option: with beveled ends (T ≥ 3,2 mm)
BS	3600	Table 5/Page 40	± 1 % min ± 0,5 mm  Cold finished tubes with less tolerances	≤ 3 %D ± 15 % > 3 %D -12,5 % + 15 %	• random • exact with tolerances: L ≤ 6 m 0 + 6 mm * L > 6 m 0 + 6 mm * + 1,5 mm per 3 m above 6 m	Visually straight	• square cut ends • free from excessive burrs

\* HF production facilities to 12,7 m + 30 mm (50 mm), over 12,7 m + 100 mm

### List of dimensional standards and technical delivery conditions standards

EN 10216-1	Seamless steel tubes for pressure purposes. TDC. Part 1: Non-alloy steel tubes with specified room temperature properties.
DIN 1629	Seamless circular tubes of non-alloy steel with special quality requirements. TDC.
DIN 1630	Seamless circular tubes of non-alloy steel with very high quality requirements. TDC.
DIN 2448	Plain end seamless steel tubes. Dimensions.
BS 3600	Dimension and masses per unit length of welded and seamless steel pipes and tubes for pressure purposes.
BS 3601	Carbon steel pipes and tubes with specified room temperature properties for pressure purposes. TDC.

#### Steel designation according to EN:

P – steel for pressure equipments  
 235 – minimum yield strength in N/mm<sup>2</sup>  
 T – steel for tubes  
 R – room temperature  
 1, 2 – group of quality  
 TR 1 - Fluid Transportation - General Purposes (see page 54)  
 TR 2 - Piping and Pressure Purposes (PED, AD 2000 Merkblatt W4)

#### Note:

Very often used steel St52 (according to DIN) is now produced as fine grain. For this reason the steel was moved to the part 3 of EN 10216, containing fine grain steel (New name is P355N).

TDC standards	Name	Steel grade			Testing and certificates		Other TDC		
		Condition	Surface	Testing	Certificate	Marking	Surface protection	Packing	
10216-1	P195TR1 P235TR1 P265TR1 P195TR2 P235TR2 P265TR2	Hot finished: Quality TR1 • as rolled • normalising formed Quality TR2 • normalising formed • normalized  Cold finished: Quality TR1 and TR2 • normalized	Visually without defects, adequate to production mode. Surface treatment possibility	Quality TR1: • non-specific • specific Quality TR2: • specific Mandatory testing: • cast analysis • tensile test • leak tightness (page 8) • dimensions • visual • impact test (TR2) at room temperature	10204 • 2.2 • 3.1 (3.2)  • 3.1 • 3.2 (see also page 7)	D ≤ 51 mm – label D > 51 mm – data on tube end Data: • manufacturer • EN standard • steel • specific inspection - cast number - mark of insp. represent. - identification number	• without protection • upon agreement	bundle 300–3500 kg	
1629	St 37.0 St 44.0 St 52.0	Hot finished: • as rolled • condition N after normalizing only upon agreement Cold finished: • normalized – condition NBK		• tensile test • ring • leak tightness (page 8) • dimensions • visual • chemical composition (scope of inspection certificate of series 3)	50049 • 2.2 • 3.1.A • 3.1.B • 3.1.C	As at EN, plus • letter S • at 2470T1 if the pipes are determined for gasline • at DIN 1630 mark of NDT (upon agreement)			
1630	St 37.4 St 44.4 St 52.4			• tensile test • ring • leak tightness (page 8) • dimensions • visual • chemical composition (scope of inspection certificate of series 3) Upon agreement: • NDT • impact test (T > 10 mm)	50049 • 3.1.A • 3.1.B • 3.1.C				
3601	360 430	Hot finished: • as rolled • normalized  Cold finished: • normalized		• tensile test • flattening • impact test • visual • leak tightness (page 8) • hydrotest or NDT	• test certificate • test results				

### Steels grades, chemical composition and mechanical properties

Standards	Steel	Chemical composition [%]										Mechanical properties				
		C	Si	Mn	Pmax	Smax	Cr	Ni	Mo	Cu	Other	Re min MPa	Re min ksi	Rm min MPa	Rm max MPa	A5 min %
<b>STN, ČSN</b>																
	11 353	max.0,18			0,050	0,050						235		340	440	25
	11 453	max.0,24			0,050	0,050						265		441	539	21
	11 503	max.0,18	max.0,55	max.1,60	0,035	0,035	max.0,30	max.0,30		max.0,30	Al min.0,015 Nb 0,015–0,08	355		490	630	22
	11 523	max.0,22	max.0,55	max.1,60	0,035	0,035					Al min.0,015	353		510	628	23
<b>ASTM</b>																
A 53	GradeA	0,25		0,95	0,050	0,045	0,40	0,40	0,15	0,40	V 0,08	205	30	330		48
	GradeB	0,30		1,20	0,050	0,045	0,40	0,40	0,15	0,40	V 0,08	240	35	415		60
<b>DIN</b>																
1629	St 37.0	max.0,17			0,040	0,040						235		350	480	25
	St 44.0	max.0,21			0,040	0,040						275		420	550	21
	St 52.0	max.0,22			0,040	0,035					Al min.0,02	355		500	650	21
1630	St 37.4	max.0,17	max.0,35	min.0,35	0,040	0,040					Al min.0,02	235		350	480	25
	St 44.4	max.0,20	max.0,35	min.0,40	0,040	0,040					Al min.0,02	275		420	550	21
	St 52.4	max.0,22	max.0,55	max.1,60	0,040	0,035					Al min.0,02	355		500	650	21
<b>BS</b>																
3601	360	max.0,17	max.0,35	0,40–0,80	0,040	0,040					Al max.0,06	235		360	500	25
	430	max.0,21	max.0,35	0,40–1,20	0,040	0,040					Al max.0,06	275		430	570	22
<b>NF A</b>																
49-112	TU E 220A	max.0,20	max.0,40	max.0,85	0,045	0,045						220		360	500	23
	TU E 235A	max.0,24	max.0,40	max.1,05	0,045	0,045						235		410	550	21
<b>EN</b>																
10216-1	P 195 TR1	max.0,13	max.0,35	max.0,70	0,025	0,020	max.0,30	max.0,30	max.0,08	max.0,30	V max.0,02 Ti max.0,04	195		320	440	27
	P 195 TR2	max.0,13	max.0,35	max.0,70	0,025	0,015	max.0,30	max.0,30	max.0,08	max.0,30	V max.0,02 Ti max.0,04 Al min.0,02	195		320	440	27
	P 235 TR1	max.0,16	max.0,35	max.1,20	0,025	0,020	max.0,30	max.0,30	max.0,08	max.0,30	V max.0,02 Ti max.0,04	235		360	500	25
	P 235 TR2	max.0,16	max.0,35	max.1,20	0,025	0,015	max.0,30	max.0,30	max.0,08	max.0,30	V max.0,02 Ti max.0,04 Al min.0,02	235		360	500	25
	P 265 TR1	max.0,20	max.0,40	max.1,40	0,025	0,020	max.0,30	max.0,30	max.0,08	max.0,30	V max.0,02 Ti max.0,04	265		410	570	21
	P 265 TR2	max.0,20	max.0,40	max.1,40	0,025	0,015	max.0,30	max.0,30	max.0,08	max.0,30	V max.0,02 Ti max.0,04 Al min.0,02	265		410	570	21

## Seamless steel tubes for pressure equipments for room temperatures

Standards	Dimensional standards	Dimensional range	Dimensions				
			Tolerance D	Tolerance T	Lengths	Straightness	Tube ends
NFA	49-112	Table 5/Page 40	±1% min ±0,5 mm	D ≤ 101,6 mm, T ≤ 10 mm ±12,5 % min ±0,5 mm D ≤ 101,6 mm, T > 10 mm ±10 % D > 101,6 mm see Tab. 4 of Standard	• random • exact with tolerances: L ≤ 8 m 0 +10 mm * L > 8 m 0 +15 mm *	3 mm/m, total 0,2 % of length	• square cut ends • free from excessive burrs • option: with beveled ends (D ≥ 42,4 mm)
	49-210		D ≤ 38 mm ±0,25 mm D > 38 mm ±0,75 %	±10 %. min. ±0,20 mm Weight -8 % +10 %			
UNI	7287		D ≤ 50 mm ±0,5 mm D > 50 mm ±1 %	-15 %  Weight ±10 %	• random • exact with tolerances: L ≤ 6 m 0 +10 mm L > 6 m 0 +15 mm		
STN ČSN	42 5715 42 5716 (42 6710) (42 6711)	Table 23/Page 68	42 5715 D ≤ 219 mm ±1,25 % min ±0,5 mm 42 5716 D ≤ 219 mm ±1 % min ±0,5 mm 42 6710 ±1 % min ±0,4 mm 42 6711 see precision tubes	-15 % +12,5 %  ±12,5 %  T ≤ 3 mm -10 % +15 % T > 3 mm -10 % +12 %	• random • exact 0 +15 mm * • multiple +5 mm on cut, max +50 mm	• straightened 3 mm/m • precise straightened 1,5mm/m • marking . +1 . +2 behind DS	• square cut ends • free from excessive burrs • option: with beveled ends
GOST	8732	Table 6/Page 42	See page 28				
PN-H	74219	Table 5/Page 40	D ≤ 50 mm ± 0,50 mm Nad 50 mm Class of precision D1 = ± 1,25% Class of precision D2 = ± 1,00%	Class of precision D1 = ± 15% Class of precision D2 D ≤ 130 mm ± 10% D = 130 - 320 mm ± 12,5% D > 320 mm ± 15%	• random 4 - 12,5 m • exact up to 7 m: L ≤ 6 m 0 + 10 mm * L > 6 m 0 + 15 mm * • multiple + 5 mm on cut • fixed ± 500 mm	• T up to 20 mm 1,5 mm/m • T > 20 mm 2,0 mm/m	• square cut ends • beveled ends for D > 101,6 mm and T up to 16 mm
ASTM ASME	A53 SA-53	See page 18					
JIS	G3454	Tab 12/Page 47	Hot finished: D ≤ 40 mm ±0,5 mm D = 50-125 mm ±1 % D > 150 mm ±1,6 mm Cold finished: D ≤ 25 mm ±0,3 mm D > 32 mm ±0,8 %	T ≤ 4 mm -0,5 mm +0,6 mm T > 4 mm -12,5 % +15 %  T ≤ 3 mm ±0,3 mm T > 3 mm ±10 %		Visually straight	• square cut ends • free from excessive burrs • option: with beveled ends
	G3455		Hot finished: D ≤ 50 mm ±0,5 mm D = 50-160 mm ±1 % Cold finished: D ≤ 40 mm ±0,3 mm D > 40 mm ±0,8 %	T ≤ 4 mm ±0,5 mm T > 4 mm ±12,5 %  T ≤ 2 mm ±0,2 mm T > 2 mm ±10 %			

\* HF production facilities to 12,7 m + 30 mm (50 mm), over 12,7 m + 100 mm

### List of dimensional standards and technical delivery conditions standards

NFA 49-112	Steel tubes. Plain end seamless hot rolled tubes with specified room temperature properties and with special delivery conditions. TDC.
NFA 49-210	Steel tubes – Seamless cold drawn tubes for fluids piping. Dimensions. TDC.
UNI 7287	Seamless plain end tubes made from basis non-alloy steel.
STN 42 0250	ČSN 42 0250 Hot formed seamless tubes from steel class 10 to 16. TDC.
STN 42 5715	ČSN 42 5715 Hot formed seamless steel tubes. Dimensions.
STN 42 5716	ČSN 42 5716 Hot formed seamless steel tubes with smaller tolerances. Dimensions.
GOST 8731	Seamless hot-formed steel pipes. TDC.
GOST 8732	Seamless hot-formed steel pipes. Dimensions.
PN-H 84018	Low-alloy steel with higher properties.
PN-H 74219	Hot rolled seamless steel tubes for structural and distribution purposes.
PN-H 84023/07	Steel for higher purposes. Steel for tubes.
ASTM A53	Pipe, steel, black and hot-dipped, zinc-coated, welded and seamless.
ASTM A530	General requirements for specialized carbon and alloy steel pipe.
JIS G 3454	Carbon steel pipes for pressure service.
JIS G 3455	Carbon steel pipes for high pressure service.

TDC standards	Name	Steel grade		Testing and certificates		Other TDC		
		Condition	Surface	Testing	Certificate	Marking	Surface protection	Packing
49-112	TU E220A TU E235A	Hot finished • as rolled Cold finished • normalized	Visually without defects, adequate to production mode. Surface treatment possibility.	<ul style="list-style-type: none"> <li>product analysis</li> <li>tensile test</li> <li>flattening</li> <li>drift expanding</li> <li>leak tightness (page 11)</li> <li>dimensions</li> <li>visual</li> <li>upon agreement NDT</li> </ul>	49-000 49-001 Type A Type B Type D (CCPU)	D < 26,9 mm label D > 26,9 mm each tube or label	<ul style="list-style-type: none"> <li>without protection</li> <li>upon agreement</li> </ul>	bundle 300 – 3500 kg
49-210	TU 37B TU 42B	Cold finished • normalized				D > 48,3 mm each tube		
7287	Fe 320	Hot finished • as rolled Cold finished • normalized						
42 0250 (42 0260)	11 353* 11 453 11 503 11 523 11 550 11 650 12 040 12 050 12 060	Hot finished • as rolled condition .1 behind steel designation Cold finished • normalized condition .1 behind steel designation	0+ scaled .1+ pickled .5+ asphalt .6+ zinc coated Cold finished .4+ metallic clean .9+ special agreement (first number behind DS)	<ul style="list-style-type: none"> <li>tensile test</li> <li>Upon agreement:</li> <li>hardness</li> <li>flattening</li> <li>drift expanding</li> <li>leak tightness (page 11)</li> <li>NDT</li> </ul>	42 0250 .0+ acknowledgement .1+ test certificate .2+ customer agreement .9+ agreement	<ul style="list-style-type: none"> <li>label</li> <li>colour stripes</li> </ul>		
8731 (1050)	10 20 35 45	See page 29						
74219 (84023) (84018)	R35, R45 18G2A	Hot finished • as rolled • other condition according to agreement Cold finished • normalized	Visually without defects, adequate to production mode. Surface treatment possibility.	Pipeline - Groups of tests A1-3 Structural - Groups of tests B1-3 <ul style="list-style-type: none"> <li>dimensions - all groups</li> <li>surface - all groups</li> <li>composition - all except A1</li> <li>leak tightness - A1 - 3</li> <li>mechanical - all except A1, B1</li> <li>technological - A3, B3</li> </ul>	<ul style="list-style-type: none"> <li>compliance with PN-H</li> <li>certificate</li> </ul>	D ≤ 31,8 mm, T ≤ 3,2 mm label on bundle D and T over - each tube Data: • producer • steel • cast number (at alloy steels)	<ul style="list-style-type: none"> <li>black tubes (CZ)</li> <li>according to agreement</li> </ul>	
ASTM A53/A530	Grade A Grade B	See page 19						
G3454	STPG 370 STPG 410	Hot finished • as rolled Cold finished • normalized		<ul style="list-style-type: none"> <li>product analysis</li> <li>tensile test</li> <li>flattening</li> <li>impact test</li> <li>hydrotest or NDT</li> <li>dimensions</li> </ul>	G0303	<ul style="list-style-type: none"> <li>steel</li> <li>process (-S-H, -S-C)</li> <li>dimensions</li> <li>manufacturer - at JIS G3454</li> <li>symbol Z3 or Z4 Z3 - ultrasonic Z4 - eddy current - at JIS G 3455</li> <li>Z2, Z3, Z4, Z5 Z2 - yield elev. temperat. Z5 - impact test</li> </ul>		
G3455	STS 370 STS 410 STS 480							

\* Mainly the first four steels are used for pressure purposes and as steels for building. All steels are used for machine and common purposes (see pages 20 and 21).

### Steels grades, chemical composition and mechanical properties

Standards	Steel	Chemical composition [%]										Mechanical properties				
		C	Si	Mn	Pmax	Smax	Cr	Ni	Mo	Cu	Other	Re min MPa	Re min ksi	Rm min MPa	Rm max MPa	A5 min %
<b>GOST</b>																
1050	10	0,07–0,14	0,17–0,37	0,35–0,65			max.0,15					205		330		31
	20	0,17–0,24	0,17–0,37	0,35–0,65			max.0,25					245		410		25
	35	0,32–0,40	0,17–0,37	0,50–0,80			max.0,25					315		530		20
	45	0,42–0,50	0,17–0,37	0,50–0,80			max.0,25					355		600		16
<b>JIS</b>																
G3454	STPG 370	max.0,25	max.0,35	0,30–0,90	0,040	0,040						215		370		30
	STPG 410	max.0,30	max.0,35	0,30–1,00	0,040	0,040						245		410		25
G3455	STS 370	max.0,25	0,10–0,35	0,30–1,10	0,035	0,035						215		370		30
	STS 410	max.0,30	0,10–0,35	0,30–1,40	0,035	0,035						245		410		25
	STS 480	max.0,33	0,10–0,35	0,30–1,50	0,035	0,035						275		480		25
<b>PN-H</b>																
84023/07	R35	0,07–0,16	0,12–0,35	0,40–0,75	0,040	0,040	max.0,30	max.0,30	max.0,10	max.0,30		215		360		24
	R45	0,16–0,22	0,12–0,35	0,60–1,2	0,040	0,040	max.0,30	max.0,30	max.0,10	max.0,30		255		430		22
	18G2A	max.0,2	0,20–0,55	max.1,6	0,040	0,040	max.0,30	max.0,30	max.0,10			365		510		22

## Seamless boiler tubes for pressure equipments (high temperature)

Standards	Dimensional standards	Dimensional range	Dimensions				Straightness	Tube ends
			Tolerance D	Tolerance T	Lengths			
EN	10216-2	Table 5/Page 40	Outside diameter $D \pm 1\%$ min $\pm 0,5$ mm	$\pm 12,5\%$ ( $D \leq 219,1$ mm) min $\pm 0,4$ mm	Kinds: • random • exact  Informative values: • $D < 60,3$ mm 5–6 m • $D \geq 60,3$ mm / $T < 7,1$ mm 5–6 m or 10–14 m • $D \geq 60,3$ mm / $T \geq 7,1$ mm 5–6 m • longer (22–24 m) upon agreement	Allowed 0,0015.L on tube calculated to 1 m max. 3 mm	• square cut ends • free from excessive burrs • option: with beveled ends (see page 98)	
			Outside diameter $D \pm 1\%$ min $\pm 0,5$ mm	$T_{\min} + 28\%$ ( $D \leq 219,1$ mm) min $\pm 0,8$ mm				
			Inside diameter $d$ or $d_{\min}$ • see article 8.7.4.1 of standard • delivery upon agreement only	Wall thickness $T$				
	10305-1 upon agreement	Table 25/Page 69	Inside diameter $d$ or $d_{\min}$ • see article 8.7.4.1 of standard • delivery upon agreement only	Wall thickness $T_{\min}$	Exact length tolerances: * • $L < 6$ m 0 +10 mm • $L = 6$ –12 m 0 +15 mm • $L > 12$ m + upon agreement			
			Cold finished: $\pm 0,5\%$ min $\pm 0,3$ mm	$\pm 10\%$ min $\pm 0,2$ mm				
			Cold finished - precision: see Page 62 - 65	Cold formed – precision See page 62 - 65				
DIN	2448	Table 5/Page 40	$D < 100$ mm $\pm 0,75\%$ min $\pm 0,5$ mm $D = 100$ –320 mm $\pm 0,90\%$	$D < 130$ mm • $T \leq 2T_n - 10\% + 15\%$ • $2T_n < T < 4T_n - 10\% + 12,5\%$ • $T > 4T_n \pm 9\%$ $T_n$ - basic wall thickness according to DIN 2448	Kinds: • random • fixed $\pm 500$ mm • exact Informative values: • $D < 60,3$ mm 5–6 m • $D \geq 60,3$ mm / $T < 7,1$ mm 5–6 m or 10–14 m • $D \geq 60,3$ mm / $T \geq 7,1$ mm 5–6 m • longer upon agreement  Exact length tolerances: like EN	Visually straight	• square cut ends • free from excessive burrs	
			Cold finished: $D < 120$ mm $\pm 0,6\%$ min $\pm 0,25$ mm $D > 120$ mm $\pm 0,75\%$	according to DIN 2391-1				
	Cold formed – precision See page 62 - 65							
BS	3059-1	Table 5/Page 40	Hot finished (HFS): $\pm 1\%$ min $\pm 0,5$ mm	$\pm 12,5\%$	• random • exact with tolerances: * $L \leq 6$ m 0 +3 mm $L > 6$ m 1,5 mm/m, max 12,5 mm	Visually straight	• square cut ends • free from excessive burrs	
			Cold finished (CFS): $\pm 0,5\%$ min $\pm 0,10$ mm	$\pm 7,5\%$				
	3059-2	Class S1: $\pm 0,5\%$ min $\pm 0,10$ mm Class S2: $\pm 0,75\%$ min $\pm 0,30$ mm (Cold finished)	$\pm 7,5\%$  $\pm 10\%$					
		3602-1 3604-1	Hot finished (HFS): $\pm 1\%$ min $\pm 0,5$ mm	$T/D = 3\% \pm 15\%$ $T/D = 3$ –10% $\pm 12,5\%$ $T/D > 10\% \pm 12,5\%$ ( $D < 168,3$ mm)				
	Cold finished (CFS): $\pm 0,75\%$ min $\pm 0,50$ mm		$\pm 7,5\%$					

\* HF production facilities to 12,7 m + 50 mm (30 mm), over 12,7 m + 100 mm

### List of dimensional standards and technical delivery conditions standards

EN 10216-2	Seamless steel tubes for pressure purposes. TDC. Part 2: Non-alloy and alloy steel tubes with specified elevated temperature properties.	BS 3059-2	Specification for carbon, alloy and austenitic steel tubes with specified elevated temperature properties.
DIN 2391-1	Seamless precision steel tubes. Part 1: Dimensions.	BS 3600	Dimensions and masses per unit length of seamless and welded steel pipes and tubes for pressure purposes.
DIN 2448	Plain end seamless steel tubes. Dimensions.	BS 3602-1	Steel pipes and tubes for pressure purposes: carbon and carbon manganese steel with specified elevated temperature properties. Part 1: Specification for seamless and electric resistance welded (including induction welded) tubes.
DIN 17175	Seamless steel tubes for elevated temperatures.		
BS 3059-1	Steel boiler and superheater tubes. Specification for low tensile carbon steel tubes without specified elevated temperature properties.		



TDC standards	Steel grade			Surface	Testing and certificates		Other TDC			
	Name	Condition			Testing	Certificate	Marking	Surface protection	Packing	
10216-2	P195GH P235GH P265GH	+ N + N + N		Adequate to production mode of tubes and heat treatment. Visually without defects, to remove defects surface can be worked according to appropriate standard articles. Specific working upon agreement.	Specific testing Non-alloy special steel TC1 or TC2	EN 10204 • 3.1 • 3.2	Indelibly marking D < 51 mm on label D > 51 mm at end Data • producer • standard • steel grade • TC (C - in steel) • cast (code) • inspector's mark • identification number Optionally: • additional marking upon agreement	• without • upon agreement		
	16Mo3 14MoV6-3 10CrMo5-5 13CrMo4-5 10CrMo9-10 (11CrMo9-10) (25CrMo4) X11CrMo5 X11CrMo5 (X11CrMo9-1) X11CrMo9-1 X10CrMoVNb9-1 X10CrMoVNb9-2 7CrWVMoNb 9-6 7CrMoVTiB 10-10	+ N + NT + NT + NT + NT + QT + QT + NT1 + NT2 + I + NT + NT + NT + NT (+ QT) + NT (+ QT)	Conditions for: Hot finished Cold finished + N - normalized + NT - normalized + tempered + QT - quenching and tempered + I - izothermal annealed Normalising formed includes normalizing		Alloy special steel - TC2 Mandatory testing: • product analysis • tensile test • flattening or ring expanding • drift expanding • leak tightness (Page 8) • dimensions • visual • NDT (at TC2) (Page 8) • material identification (at alloy steel) • impact test according to steel grade and dimensions Optional testing upon agreement	See also page 7				
17175	St 35.8 St 45.8 17Mn4 19Mn5 15Mo3	Hot finished • as rolled • normalized Cold finished • normalized			Quality class I. or III.	DIN 50049 Kinds of protocol like EN	Usually die stamping or agreement At both ends Data: • steel • grade of quality (C-steel) • manufacturer • inspector • colorstrap At one end for D ≥ 159 mm • cast number • tube number (III. grade)			
	13CrMo4 4 10CrMo9 10	Hot finished: • tempered • normalized and tempered Cold finished • normalized and tempered			Quality class III. Testing like EN					
	14MoV6 3	Hot finished Cold finished • normalized and tempered (both methods)								
3059-1	320	Hot finished • as rolled (HF) • normalized (N) Cold formed • normalized			• visual • tensile test • flattening • drift expanding • leak tightness (hydrotest or NDT)	Standard requirements execution	Indelibly marking Usually die stamping at one end or Label on the bundle Data: • manufacturer • standard • steel • identification number • cast ( at 3604-1)	• without • upon agreement		
3059-2	360 440	Cold finished • normalized								• testing category 1 with NDT • testing category 2 with hydrotest Other tests like BS 3059-1
	243 620	N N (N + T)								
	622 - 490	N + T or Ann (tempered)								
3602-1	360 430	Hot finished • as rolled (HF) • normalized (N) Cold formed • normalized		• visual • tensile test • flattening • testing category 1 with NDT - ultrasonic • testing category 2 with NDT - eddy current						
3604-1	620 - 440 621 660 622	N + T* N + T N + T N + T								

- BS 3604-1 Steel pipes and tubes for pressure purposes: ferritic alloy steel with specific elevated temperature properties. Part 1: Specification for seamless and electric resistance welded tubes.
- BS 3606 Steel tubes for heat exchangers. ISO 9329-2 See EN 10216-2

Testing comparison	
DIN 17175	EN 10216-2
Quality class	Testing category
I	TC 1
III	TC 2

### Boiler steel designation according to EN:

- base non-alloy steel  
P – steel for pressure equipments  
235 – minimum yield strength in N/mm<sup>2</sup>  
G – general characteristic, devise to second symbol  
H – high temperature
- alloy steel  
steel designated according to chemical composition

## ▶▶▶ Seamless boiler tubes for pressure equipments (high temperature)

Standards	Dimensional standards	Dimensional range	Dimensions				
			Tolerance D	Tolerance T	Lengths	Straightness	Tube ends
NF A	49-211	Table 5/Page 40	D ≤ 48,3 mm -0,8 +0,4 mm D = 60,3–114,3 mm ±0,8 mm D = 139,7–219,1 mm -0,8 +1,6 mm Tube weight -3,5 +10 %	T ≤ 3,2 mm -0,15T +0,5 mm T = 3,2–20 mm -0,125T +0,15T	Exact lengths tolerances: * • L ≤ 8 m 0 +10 mm • L > 8 m 0 +15 mm	max. 3 mm/m total 0,15 % tube length	• square cut ends tol. 0,5 %D (min. 0,5 mm, max. 1,6 mm) • beveled D > 60,3
	49-213		Hot finished: D ≤ 63,5 mm ±0,50 mm D = 63,5–114,3 mm ±0,75 % D > 114,3 mm ±1 % Cold finished: D ≤ 33,7 mm ±0,25 mm D > 33,7 mm ±0,5 % min ±0,25 mm	±12,5 % min ±0,4 mm  ±10 %	Exact lengths tolerances: * • D ≤ 88,9 mm a L ≤ 7,5 m 0 +5 mm • D > 88,9 mm 0 +10 mm • L > 7,5 m +1 mm/1 m	max. 3 mm/m total by length 6 m = 8 mm	• square cut ends • free from excessive burrs
UNI	(ISO 1129) Pipelines 4991		Hot finished: D ≤ 51 mm ±0,5 mm D = 51–419 mm ±1 % Cold finished: D ≤ 139,7 mm ±0,75 % min ±0,3 mm  Tube weight -8 +10%	D ≤ 139,7 mm ±12,5 %  ±10 %	Exact lengths tolerances: * • L ≤ 6 m 0 +10 mm • L > 6 m 0 +15 mm		• square cut ends • free from excessive burrs
STN ČSN	42 5715 42 5716 (42 6710) (42 6711)	(Table 25/Page 69)	42 5715 D ≤ 219 mm ±1,25 % min ±0,5 mm	D < 219 mm, T < 20 mm -15 % +12,5 %	Exact lengths tolerances: * 0 +15 mm Multiple: +5 mm na rez, max. +50 mm	Straightened - 3 mm/m Exact straightened 1,5 mm/m Marking: .+1 .+2 za RN	• square cut ends • free from excessive burrs • option: with beveled ends
			42 5716 D ≤ 219 mm ±1 % min ±0,5 mm	D < 219 mm, T < 20 mm ±12,5 %			
			42 6710 ±1 % min ±0,4 mm	T ≤ 3 mm -10 % +15 % T > 3 mm -10 % +12 %			
			42 6711 see precision tubes				
GOST	8732	Table 6/Page 42	D ≤ 50 mm ±0,50 mm D = 50–219 mm usually ±1 % increased ±0,8 %	D ≤ 219 mm, T ≤ 15 mm usually -15% +12,5% increased ±12,5%	Exact lengths tolerances: * • L ≤ 6 m 0 +10 mm • L > 6 m 0 +15 mm	1,5 mm/m	• square cut ends • option: beveled for T 5–20 mm
	TU 14-3-190		usually D ≤ 50 mm ±0,40 mm 50 < D ≤ 114 ±1 % 114 < D ≤ 245 ±1 %	usually -10% / + 12,5 % -10% / + 15,0 % -5% / + 20 %			
	TU 14-3-460		usually D ≤ 108 mm ±1% min. 0,5 mm 114 < D ≤ 245 ±1 %	usually T < 14 mm; -10% / +15% -5% / +20%			
PN-H	74252		D ≤ 50 mm ±0,50 mm D = 50–219 mm usually ±1 % increased ±0,8 %	D ≤ 219 mm, T ≤ 15 mm usually -15% +12,5% increased ±12,5%	Exact lengths tolerances: * • L ≤ 6 m 0 +10 mm • L > 6 m 0 +15 mm	1,5 mm/m	• square cut ends • option: beveled for T 5–20 mm
ANSI ASME	B36.10	Table 7/Page 44	See table 8, page 45 Except 1. row tolerance ±0,4 (not -0,8 mm)		Depending on tube dimension length upon agreement. See EN page 38	Visually straight	• square cut ends • plain ends • NPS ≤ 11/2 (DN 40/48,3 mm) agreement • NPS ≥ 2 (DN 50/60,3 mm) T ≤ XS – beveled T > XS – plain and square cut

\* HF production facilities to 12,7 m + 50 mm (30 mm), over 12,7 m + 100 mm

### List of dimensional standards and technical delivery conditions standards

NFA 49-211	Steel tubes. Seamless plain-end unalloyed steel tubes for fluid piping at elevated temperatures. Dimensions. TDC.	UNI 4991	Seamless and welded steel tubes with plain ends. Dimensions.
NFA 49-213	Steel tubes. Seamless unalloyed and Mo and Cr-Mo alloyed steel tubes for use at high temperatures. Dimensions (with standard tolerances). TDC.	UNI 5462	Seamless steel tubes - tubes for elevated temperatures and pressures.
ISO 1129	Steel tubes for boilers, superheaters and heat exchangers. Dimensions, tolerances and weight per unit lengths.	STN 42 0251	ČSN 42 0251 Seamless steel tubes with guaranteed properties of elevated temperatures.
		STN 42 5715	ČSN 42 5715 Hot formed seamless steel tubes.
		STN 42 5716	ČSN 42 5716 Hot formed seamless steel tubes with smaller tolerances.

TDC standards	Name	Steel grade		Testing and certificates		Other TDC		
		Condition	Surface	Testing	Certificate	Marking	Surface protection	Packing
49-211	TUE 220 TUE 250 TUE 275	Hot finished • as rolled • normalized Cold finished • normalized	Adequate to production mode of tubes and heat treatment. Visually without defects, to remove defects surface can be worked according to appropriate standard articles. Specific working upon agreement.	Testing as in EN • leak tightness by hydrotest – pressure according to formula	NFA 49-001 3.1.B	Indelibly marking 26,9 mm and under - label 26,9 - 48,3 mm - tube or label Over 48,3 mm - at tube Data: • manufacturer • steel, condition • standard • dimensions • pressure at test • identification number • inspector	• without • upon agreement	• D < 60,3 mm - bundles • tubes of larger diameter can be free laid
49-213	TU 37C TU 42C TU 48C TU 52C	Hot finished • as rolled • normalized Cold finished • normalized		• hot finished tubes of grade: L1, L2, L3 • cold finished tubes of grade: F1, F2, F3 • NDT ultrasonic of grade: L2, L3, F2, F3	NFA 49-001 company certificate C.C.PV (3.1.B) or inspection test 3.2.C			
	TU 15D3	N						
	TU 13CD4 - 04 TU 10CD5 - 05 TU 10CD9 - 10 TU 15CD2 - 05	N + T N + T N + T						
5462	C14 C18	Hot finished • as rolled • normalized Cold finished • normalized		• dimensions • hydrostatic test • drift expanding • flattening • tensile test • NDT upon agreement		Marking according to agreement		
	16Mo5 14CrMo3 12CrMo9 10	N N + T N + T						
42 0251	11 368 11 418 12 021 12 022 12 025 15 020	Hot finished • as rolled • normalized Cold finished • normalized condition .1 behind steel mark	.0+ scaled .1+ pickled Cold finished .2+ free of scale .4+ metallic clean 9+ special agreement (first number behind DS)	• surface • dimensions • leak tightness • tensile test • flattening • drift expanding • impact test • ring-expanding • material identification • NDT (Tube class 3) • (Tube class 1 and 3)*	• 6+ test certificate • 7+ customer inspection • 9+ special arrangement + = tube class	Colour according to ČSN 42 0010 Tested NDT – colour strip D < 70 mm label and T < 6,3 mm on bundle Marking of tubes according to EN additionally: • dimensions • quantity	• without • upon agreement	• bundles 300-3500 kg, bounded with steel stripes • other upon agreement
	15 121 15 128 15 313	Hot finished • normalized and tempered Cold finished • normalized and tempered condition .5 behind steel mark						
8731 TU 14-3-190	1050:10;20 4543:10G2 15ChM 20072: 12Ch1MF	Hot finished • as rolled, • normalized  Hot finished Cold finished norm. and temp.		• product analysis • hardness • visual • tensile test • impact test • grain size • inclusions • leak tightness • NDT	According to GOST 10692	According to GOST 10692	According to GOST 10692	According to GOST 10692
	TU 14-3P-55	20						
	TU 14-3-460	15ChM 12Ch1MF	Normalized and tempered					
74252 (84024)	K10 K18	Hot finished • as rolled, • normalized						A530 +
	16M, 10H2M 15HM 13HMF	Hot finished • Normalized and tempered						
ASTM A106 (A530) ASME SA-106 (SA-530)	Grade A Grade B Grade C	Hot finished • as rolled Cold finished • normalized		• product analysis • hardness • tensile test • impact test ( up to NPS 2") • flattening • impact test • hydrostatic or NDT – E 213, E 309, E 570 • dimensions • weight • drift expanding • flanging • (upon agreement equivalent C)	A530	A530 + A700 + article 24 of standard Under 2 in (60,3 mm) data on a label. Data: • manufacturer • standard • steel grade	A530 + A700 + article 24 of standard	A700 + article 24 of standard

\*Option of class of tubes according to working conditions (temperature, pressure) in compliance with standards ČSN 13 0020, ČSN 42 0090 and ČSN 69 0010

STN 42 6710 ČSN 42 6710 Cold drawn seamless tubes with standard tolerances. STN 42 6711

ČSN 42 6711 Precision seamless steel tubes.  
GOST 4543 Alloy structural steel. GOST 20072 Heat resistant steel.

GOST 8731 Hot formed seamless steel tubes. TDC.  
GOST 8732 Hot formed seamless steel tubes. Dimensions.  
GOST 8733 Seamless cold or hot formed steel tubes.

GOST 8734 Cold formed seamless steel tubes.  
TU 14-3-190 Seamless steel tubes for boilers and pipelines.  
TU 14-3-460 Seamless steel tubes for steam boilers and pipelines.

ANSI/ASME B 36.10M Welded and seamless wrought steel pipe. Dimensions.

## ▶▶▶ Seamless boiler tubes for pressure equipments (high temperature)

Standards	Dimensional standards	Dimensional range	Dimensions				Straightness	Tube ends
			Tolerance D	Tolerance T	Lengths			
ASTM ASME	A192 SA-192	Table 9/Page 46	Table 10/Page 47	Table 11/Page 47	Length upon agreement, depending on tube dimension. Indicative - like EN. Tolerance:  <b>A 450 a A 1016</b>  Seamless, hot finished : * All dimensions 0+3/16 in. (0+5mm)  Seamless, cold finished: D under 2 in. (50,8 mm) 0 + 1/8 in. (0+3mm)  D 2 in.(50,8 mm) and over 0 + 3/16 in. (0+ 5mm)  Welded : As seamless, cold finished Toler. for L under 24 ft. (7,3 m) L over 24 ft : 0 + 1/8 in. (+3 mm) for each 10 ft (3 m) or 0 + 1/2 in. (0+13 mm) smaller vallue is valid  <b>A 530 a A 999</b>  Seamless and welded (electric. resistant) For L under 24ft. (7,3 m) incl. 0 + 1/4 in. (0+ 6 mm) * For larger lengths under agreement (Valid for A 999) Tolerances of random lengths upon agreement.	Visually straight	<ul style="list-style-type: none"> <li>• square cut ends</li> <li>• free from excessive burrs</li> <li>• beveled ends upon agreement only</li> </ul>	
	A209 SA-209							
	A210 SA-210							
	A213 SA-213							
	A335 SA-335	Table 7/Page 44 or Table 9/Page 46	Ordering of Pipe or Tube See Table 8/Page45	See Table 8/Page45  Nominal T -12,5 % Minimum T to + only				
A556* SA-556	Table 9/Page 46 interval 5/8 - 1 1/4 in 15/9 - 31,8 mm	See Table10/Page 47	See Table 11/Page 47					
JIS	G3456	Table 13/Page 50	D ≤ 50 mm ±0,50 mm D = 50-160 mm ±1 %	T ≤ 4 mm ±0,5 mm T > 4 mm ±12,5 %			<ul style="list-style-type: none"> <li>• square cut ends</li> <li>• free from excessive burrs</li> <li>• beveled ends upon agreement only</li> </ul>	
	G3458							
	G3461	Table 12/Page 47	Hot finished Cold finished (Tolerances see standards)					D ≤ 50 mm, L ≤ 7 m 0+7 mm * D ≤ 50 mm, L > 7 m +3 mm/m, max 15 mm * D > 50 mm, L ≤ 7 m 0+10 mm * D > 50 mm, L > 7 m +3 mm/m, max 15 mm *
	G3462							

\* HF production facilities to 12,7 m + 50 mm (30 mm), over 12,7 m + 100 mm

### List of dimensional standards and technical delivery conditions standards

ASTM A106	Seamless carbon steel pipe for high-temperature service.	ASTM A450	General requirements for carbon, ferritic alloy and austenitic alloy steel tubes.
ASTM A192	Seamless carbon steel boiler tubes for high-pressure service.	ASTM A530	General requirements for specialized carbon and alloy steel pipe.
ASTM A209	Seamless carbon-molybdenum alloy-steel boiler and superheater tubes.	ASTM A556	Seamless cold drawn carbon steel feedwater heater tubes.
ASTM A210	Seamless medium-carbon steel boiler and superheater tubes.	ASTM A692	Seamless medium-strength carbon-molybdenum alloy steel boiler and superheater tubes.
ASTM A213	Seamless ferritic and austenitic alloy-steel boiler, superheater and heat-exchanger tubes. ASTM 335	ASTM A999	General requirements for alloy and stainless steel pipe.
	Seamless ferritic alloy-steel pipe for high-temperature service.	ASTM A1016	General requirements for ferritic alloy steel, austenitic alloy steel and stainless steel tubes.

TDC standards	Steel grade			Testing and certificates		Other TDC		
	Name	Condition	Surface	Testing	Certificate	Marking	Surface protection	Packing
A192 (A450) SA-192 (SA-450)	A192	Hot finished • as rolled Cold finished • normalized	Adequate to production mode of tubes and heat treatment.  Visually without defects, to remove defects surface can be worked according to appropriate standard articles. Specific working upon agreement	• product analysis • hardness • flattening • drift expanding • hydrostatic or NDT	A450	A450, A700, A1016 Under 1 1/4 in (31,8 mm) data on the label	A450 + A700	A450 + A700
A209 (A1016) SA-209 (SA-1016)	Grade T1 Grade T1a Grade T1b	Hot finished • normalized Cold finished • normalized • normalized + tempered		• product analysis • hardness • flattening • tensile test • drift expanding • hydrostatic or NDT	A1016	Data: • manufacturer • standard • steel grade	A1016 + A700	A450 + A700
A210 (A450) SA-210 (SA-450)	Grade A-1 Grade C	Hot finished • as rolled Cold finished • normalized		• product analysis • hardness • flattening • tensile test • drift expanding • hydrostatic or NDT	A450		A450 + A700	A450 + A700
A213 (A1016) SA-213 (SA-1016)	T2 T5 T11 T12 T21 T22 T24 T91	Hot finished • normalized + tempered Cold finished • normalized + tempered		• product analysis • tensile test • hardness • flattening • drift expanding • hydrostatic or NDT – E 213, E 309, E570	A1016			
A335 (A999) SA-335 (SA-999)	P1 P2 P5 P11 P12 P21 P22 P24 P91	Hot finished • normalized + tempered Cold finished • normalized + tempered		• product analysis • tensile test • hardness • dimensions • hydrostatic and NDT – E 213, E 309, EN 570 • impact test	A999	A999 Under D 2 in (60,3 mm) data on the label Data: • manufacturer • standard • steel grade		
A556 (A450) SA-556 (SA-450)	Grade A2 Grade B2 Grade C2	Cold finished • normalized		• product analysis • tensile test • hardness • dimensions • flattening • drift expanding • NDT	A450	See A209		
G3456	STPT370 STPT410 STPT480	Hot finished • as rolled Cold finished • normalized		• product analysis • tensile test • flattening • impact test • hydrostatic or NDT according to JIS G0582 or JIS G0583		Small diameters - label Data: • steel grade • method of manufact. (-S-H), (-S-C) • ND x NT / D x T • manufacturer • supplem. requirements Z		
G3458	STPA12 STPA20 STPA22 STPA23 STPA24	Hot finished • normalized + tempered Cold finished • normalized + tempered						
G3461	STB340 STB410 STB510	Hot finished • as rolled (340,410) • normalized (510)		• product analysis • tensile test • flattening • drift expanding • hydrostatic or NDT according to JIS G0582 or JIS G0583	JIS G0303	Small diameters - label Data: • class (steel) • method of manufact. (-S-H), (-S-C) • dimensions • manufacturer • supplem. requirements Z		
G3462	STBA12 STBA13 STBA20 STBA22 STBA23 STBA24	Cold finished • normalized  Hot finished • normalized + tempered Cold finished • normalized + tempered						

\* The tubes according to standard ASTM A 556 only as straight ones.

- ASTM 335 Standard specification for seamless ferritic alloy steel pipes for high-temperature service.  
 JIS G 3456 Carbon steel pipes for high temperature service.  
 JIS G 3458 Alloyed steel pipes.  
 JIS G 3461 Carbon steel boiler and heat exchanger tubes.  
 JIS G 3462 Alloy steel boiler and heat exchanger tubes.  
 PN-H 74 252 Seamless boiler steel tubes

#### NDT of boiler tubes according to ASTM (ASME SA) rules

Alloy steel tube and pipe according to standard ASTM (ASME) A 209, A 213, A 335 - it is recommended to test the tube with combination of two NDT methods - usually according to ASTM E309 and ASTM E213.

Reference standards:

ASTM E213 (ultrasonic) - the depth of the notches shall not exceed 12 1/2 % of T. (According to agreement 10% or 5%)

ASTM E309 (eddy current) - max. diameter of drilled hole:  
 for tube: 0,031 in (0,8 mm)  
 for pipe: see Table in Standards A999

ASTM E570 (flux leakage) - values as in Standard ASTM 213.

## Steels grades, chemical composition and mechanical properties

Standards	Steel	Chemical composition [%]										Mechanical properties				
		C	Si	Mn	Pmax	Smax	Cr	Ni	Mo	Cu	Other	Re min MPa	Re min ksi	Rm min MPa	Rm max MPa	min ksi
<b>STN, ČSN</b>																
	11 368	max.0,15	max.0,35	min.0,40	0,040	0,040	max.0,30	max.0,30			max.0,30		245	350	440	26
	11 418	max.0,20	max.0,35	max.0,50	0,040	0,040	max.0,30	max.0,30			max.0,30		255	400	490	24
	12 021	0,07-0,15	0,17-0,35	0,35-0,60	0,040	0,040	max.0,25	max.0,25			max.0,25		235	340	470	25
	12 022	0,15-0,22	0,17-0,37	0,50-0,80	0,040	0,040	max.0,25	max.0,25			max.0,25		255	410	570	21
	12 025	0,14-0,20	0,17-0,37	0,60-1,00	0,040	0,040	max.0,25	max.0,25			max.0,25	V 0,05-0,09	320	440	600	23
	15 020	0,12-0,20	0,15-0,37	0,50-0,80	0,040	0,040					0,25-0,35	Al min.0,015	270	450	600	22
	15 121	0,10-0,18	0,15-0,35	0,40-0,70	0,040	0,040	0,70-1,30				0,40-0,60		295	440	590	22
	15 128	0,10-0,18	0,15-0,40	0,45-0,70	0,040	0,040	0,50-0,75				0,40-0,60	V 0,22-0,35	365	490	690	18
	15 313	0,08-0,15	0,15-0,40	0,40-0,80	0,035	0,035	2,00-2,50				0,90-1,10		265	480	630	20
<b>BS</b>																
	3059/1	320	max.0,16	0,10-0,35	0,30-0,70	0,040	0,040						195	320	480	25
	3059/2	360	max.0,17	0,10-0,35	0,40-0,80	0,035	0,035						235	360	500	24
		440	0,12-0,18	0,10-0,35	0,90-1,20	0,035	0,035						245	440	580	21
		243	0,12-0,20	0,10-0,35	0,40-0,80	0,035	0,035				0,25-0,35	Al max.0,012	275	480	630	22
		620-460	0,10-0,15	0,10-0,35	0,40-0,70	0,035	0,035	0,70-1,10			0,45-0,65	Al max.0,020	180	460	610	22
<b>ASTM</b>																
	A 106	GradeA	0,25	min.0,10	0,27-0,93	0,035	0,035	0,40	0,40	0,15	0,40	V 0,08	205	30	330	48
	A 556	GradeB	0,30	min.0,10	0,29-1,06	0,035	0,035	0,40	0,40	0,15	0,40	V 0,08	240	35	415	60
	(Grade A2)	GradeC	0,35	min.0,10	0,29-1,06	0,035	0,035	0,40	0,40	0,15	0,40	V 0,08	275	40	485	70
	A 192		0,06-0,18	max. 0,25	0,27-0,63	0,035	0,035					137HB/77HRB	180	26	325	47
	A 209	Grade T1	0,10-0,20	0,10-0,50	0,30-0,80	0,025	0,025				0,44-0,65		205	30	380	55
		Grade T1a	0,15-0,25	0,10-0,50	0,30-0,80	0,025	0,025				0,44-0,65		195	28	365	53
		Grade T1b	max.0,14	0,10-0,50	0,30-0,80	0,025	0,025				0,44-0,65		220	32	415	60
	A 210	Grade A-1	max. 0,27	min. 0,10	max. 0,93	0,035	0,035						255	37	415	60
		Grade C	max. 0,35	min. 0,10	0,29-1,06	0,035	0,035						275	40	485	70
	A 213	Grade T11	0,05-0,15	0,50-1,00	0,30-0,60	0,025	0,025	1,00-1,50	max. 0,40		0,44-0,65		205	30	415	60
	A 335	Grade T12	0,05-0,15	max. 0,50	0,30-0,61	0,025	0,025	0,80-1,25			0,44-0,65		220	32	415	60
	(Grade P)	Grade T22	0,05-0,15	max.0,50	0,30-0,60	0,025	0,025	1,90-2,60			0,87-1,13		205	30	415	60
		Grade T24	0,05-0,10	0,15-0,45	0,30-0,70	0,020	0,010	2,20-2,60			0,90-1,10	V, Ti, B	415	60	585	85
		Grade T2	0,10-0,20	0,10-0,30	0,30-0,61	0,025	0,025	0,50-0,81			0,44-0,65		205	30	380	55
		Grade T21	0,05-0,15	max. 0,50	0,30-0,60	0,025	0,025	2,65-3,35			0,80-1,06		205	30	415	60
		Grade T5	max.0,15	max. 0,50	0,30-0,60	0,025	0,025	4,00-6,00			0,45-0,65		205	30	415	60
		Grade T91	0,08-0,12	0,20-0,50	0,30-0,60	0,020	0,010	8,00-9,50			0,85-1,05	V, Nb	415	60	585	85
<b>DIN</b>																
	17175	St 35.8	max.0,17	0,10-0,35	0,40-0,80	0,040	0,040						235	360	480	25
		St 45.8	max.0,21	0,10-0,35	0,40-1,20	0,040	0,040						255	410	530	21
		17Mn4	0,14-0,20	0,20-0,40	0,90-1,20	0,040	0,040	max.0,30					270	460	580	23
		19Mn5	0,17-0,22	0,30-0,60	1,00-1,30	0,040	0,040	max.0,30					310	510	610	19
		15Mo3	0,12-0,20	0,10-0,35	0,40-0,80	0,035	0,035				0,25-0,35		270	450	600	22
		13CrMo44	0,10-0,18	0,10-0,35	0,40-0,70	0,035	0,035	0,70-1,10			0,45-0,65		290	440	590	22
		10CrMo9 10	0,08-0,15	max. 0,50	0,40-0,70	0,035	0,035	2,00-2,50			0,90-1,20		280	450	600	20
		14MoV 6 3	0,10-0,18	0,10-0,35	0,40-0,70	0,035	0,035	0,30-0,60			0,50-0,70	V 0,22-0,32	320	460	610	20
<b>UNI</b>																
	5462	C14	max.0,17	0,10-0,35	max.0,40	0,035	0,035						240	350	450	28
		C18	max.0,21	0,10-0,35	max.0,50	0,035	0,035						260	450	550	23
		16Mo5	0,12-0,20	0,15-0,35	0,50-0,80	0,035	0,035				0,45-0,65		290	450	550	22
		14 CrMo3	0,10-0,18	0,15-0,35	0,40-0,70	0,035	0,035	0,70-1,00			0,45-0,65		294	441	569	22
		12CrMo9-10	max.0,15	0,15-0,50	0,40-0,60	0,035	0,035	2,00-2,50			0,90-1,10		265	441	588	20
<b>PN-H</b>																
	84024	K10	max.0,17	0,10-0,35	min. 0,40	0,045	0,045	max. 0,20	max. 0,35		max. 0,25		235	340	440	25
		K18	0,16-0,22	0,10-0,35	min. 0,60	0,045	0,045	max. 0,20	max. 0,35		max. 0,25		255	440	540	21
		16M	0,12-0,20	0,15-0,35	0,50-0,80	0,040	0,040	max. 0,30	max. 0,35	0,25-0,35	max. 0,25	Al max 0,020	285	440	540	22
		15HM	0,11-0,18	0,15-0,35	0,40-0,70	0,040	0,040	0,70-1,10	max. 0,35	0,40-0,55	max. 0,25	Al max 0,020	295	440	570	22

## Indicative comparison of steel grade for boiler tubes

Standard	Maximal temperature [°C]							
	450 – 475 – 500 (by test category)				500 – 530		550 – 560	
EN 10216-2 (W.Nr.)	P235GH	P265GH	(P295GH)	(P310GH)	16Mo3			
DIN 17175 (W.Nr.)	1.0345	1.0425			1.5415			
DIN 17176 (W.Nr.)	St 35.8	St 45.8	17Mn4	19Mn5	15Mo3			
BS 3059-1	1.0305	1.0405	1.0481	1.0482	1.5415			
BS 3059-2	320				16Mo5			
BS 3602-1	360	440			1.5423			
BS 3604	360	430		500Nb	243			
NFA 49-211	TUE220B	TUE250B	TUE275B					
UNI 5462	TU37C	TU42C	TU48C	TU52C	TU15D3	16Mo5		TU15CD2-05
STN 42 0251	C14	C18						
GOST 1050	12 021	12 022			15 020			
GOST 4543	10	20						
GOST 20072								
PN-H 84024	K10	K18			16M			
ASTM A106	Grade A	Grade B	Grade C					
ASTM A192	A192							
ASTM A209							T1, T1a, T1b	
ASTM A210		Grade A-1	Grade C					
ASTM A213								T2
ASTM A335								P1
ASTM A556	Grade A2	Grade B2	Grade C2					P2
ASTM A692								A692
JIS G 3456	STPT370	STPT410	STPT480					
JIS G 3458					STPA12			STPA20
JIS G 3461	STB340	STB410	STB510					
JIS G 3462					STBA12	STBA13		STBA20



Standards	Steel	Chemical composition [%]										Mechanical properties					
		C	Si	Mn	Pmax	Smax	Cr	Ni	Mo	Cu	Other	Re min MPa	Re min ksi	Rm min MPa	Rm max ksi	A5 min %	
<b>NFA</b>																	
49-211	TU E220	max.0,17	max.0,35	max.0,85	0,030	0,030							220	370	490	26	
	TU E250	max.0,23	max.0,40	max.1,05	0,030	0,030							250	410	530	23	
49-213	TU E275	max.0,25	max.0,45	max.1,40	0,030	0,030						max.0,25	Sn max.0,03	275	470	590	20
	TU 37C	max.0,18	0,05-0,35	0,30-0,80	0,040	0,040						max.0,25	Sn max.0,03	220	360	460	
	TU 42C	max.0,22	0,07-0,40	0,40-1,05	0,040	0,040						max.0,25	Sn max.0,03	235	410	510	
	TU 48C	max.0,24	0,09-0,40	0,60-1,30	0,040	0,040						max.0,25	Sn max.0,03	275	470	570	
	TU 52C	max.0,22	0,13-0,55	0,95-1,60	0,040	0,040						max.0,25	Sn max.0,03	350	510	630	
	TU 15D3	0,10-0,22	0,10-0,40	0,40-0,90	0,040	0,040	max.0,40	max.0,30	0,21-0,39			max.0,25	Sn max.0,03	265	430	550	22
	TU 13CD4-04	0,08-0,20	0,05-0,40	0,30-0,80	0,035	0,035	0,65-1,15	max.0,30	0,41-0,69			max.0,25	Sn max.0,03	290	440	590	22
	TU 15CD2-05	0,08-0,20	0,05-0,40	0,40-1,00	0,035	0,035	0,30-0,75	max.0,30	0,41-0,64			max.0,25	Sn max.0,03	275	440	570	22
<b>EN</b>																	
10216-2	P 195 GH	max. 0,13	max. 0,35	max. 0,70	0,025	0,010	max.0,30	max.0,30	max.0,08	max.0,30		V max. 0,02 Ti max.0,04 Al min. 0,020	195	320	440	27	
	P 235 GH	max. 0,16	max. 0,35	max.1,20	0,025	0,010	max.0,30	max.0,30	max.0,08	max.0,30		V max. 0,02 Ti max.0,04 Al min. 0,020	235	360	500	25	
	P 265 GH	max.0,20	max.0,40	max.1,40	0,025	0,010	max.0,30	max.0,30	max.0,08	max.0,30		V max. 0,02 Ti max.0,04 Al min. 0,020	265	410	570	23	
	14MoV 6-3	0,10-0,18	0,10-0,35	0,40-0,70	0,025	0,010	0,30-0,60		0,50-0,70			V 0,22-0,28	320	460	610	20	
	7CrWVMoNb9-6	0,04-0,10	max. 0,5	0,10-0,60	0,030	0,010	1,90-2,60		0,05-0,30			W 1,45-1,75 V 0,20-0,30 Al max. 0,030 Nb 0,02-0,08	400	510	470	20	
	7Cr MoVTiB10-10	0,05-0,10	0,15-0,45	0,30-0,70	0,020	0,010	2,20-2,60		0,90-1,10			V 0,02-0,03 Al max.0,020 B 0,015-0,070 N max.0,010	450	565	840	17	
	16Mo3	0,12-0,20	0,15-0,35	0,40-0,90	0,025	0,010			0,25-0,35			Al max. 0,040	280	450	600	22	
	10CrMo5-5	max. 0,15	0,50-1,00	0,30-0,60	0,025	0,010	1,00-1,50	max.0,30	0,45-0,65	max.0,30		Al max. 0,040	275	410	560	22	
	13CrMo4-5	0,10-0,17	0,15-0,35	0,40-0,70	0,025	0,010	0,70-1,15		0,40-0,60			Al max. 0,040	290	440	590	22	
	10CrMo 9-10 (25CrMo4)	0,08-0,14 0,22-0,29	max. 0,5 max. 0,4	0,30-0,70 0,6-0,9	0,020 0,035	0,010	2,0-2,5 0,9-1,2	max. 0,30	0,90-1,10 0,15-0,30	max. 0,30		Al max. 0,040	280 700	480 900	630 900	22 12	
(X 11 CrMo5+) X 11 CrMo5+NT1 X 11 CrMo5+NT2	0,08-0,15	0,15-0,50	0,30-0,60	0,025	0,010	4,00-6,00		0,45-0,65	max. 0,30			175 280 390	430 480 570	580 640 740	22 20 18		
X10CrMoVNb9-1	0,08-0,12	0,20-0,50	0,30-0,60	0,020	0,005	8,00-9,00	max. 0,40	0,85-1,05	max. 0,30		V 0,18-0,25 Nb 0,06-0,10 N 0,03-0,07	450	630	830	19		
<b>GOST</b>																	
1050	10	0,07-0,14	0,17-0,37	0,35-0,65			max.0,15						205	330		31	
	20	0,17-0,24	0,17-0,37	0,35-0,65			max.0,25						245	410		25	
4543	10G2	0,07-0,15	0,17-0,37	1,20-1,60									245	420		22	
	15ChM	0,11-0,18	0,17-0,37	0,40-0,70				0,80-1,10		0,40-0,65			275	440		21	
20072	12Ch1MF	0,10-0,15	0,17-0,37	0,40-0,70	0,030	0,025	0,90-1,20	max.0,30	0,25-0,35			V 0,15-0,30	235	410		21	
<b>JIS</b>																	
G3456	STPT 370	max.0,25	0,10-0,35	0,30-0,90	0,035	0,035							215	370		30	
	STPT 410	max.0,30	0,10-0,35	0,30-1,00	0,035	0,035							245	410		25	
	STPT 480	max.0,33	0,10-0,35	0,30-1,00	0,035	0,035							275	480		25	
G3458	STPA 12	0,10-0,20	0,10-0,50	0,30-0,80	0,035	0,035			0,45-0,65				205	380		30	
	STPA 22	max.0,15	max.0,50	0,30-0,60	0,035	0,035	0,80-1,25		0,45-0,65				205	410		30	
G3461	STB 340	max.0,18	max.0,35	0,30-0,60	0,035	0,035							175	340		35	
	STB 410	max.0,32	max.0,35	0,30-0,80	0,035	0,035							255	410		25	
	STB 510	max.0,25	max.0,35	1,00-1,50	0,035	0,035							295	510		25	
G3462	STBA 12	0,10-0,20	0,10-0,50	0,30-0,80	0,035	0,035			0,45-0,65				205	380		30	
	STBA 22	max.0,15	max.0,50	0,30-0,60	0,035	0,035	0,80-1,25		0,45-0,65				205	410		30	

Note: For selection of steel grades are applied the regulations for design of boilers

Table 4

575 - 580		600		625		650		675	
13CrMo4-5 1.7335	14MoV6-3 1.7715	10CrMo5-5 1.7338	10CrMo9-10 1.7380	X11CrMo5+I 1.7362	X11CrMo9-1+I 1.7386	X20CrMoV11-1 1.4922	X10CrMoVNb9-1 1.4903	X10CrWMoVNb9-2 1.4901	
13CrMo4 4 1.7335	14MoV6 3 1.7715		10CrMo9 10 1.7380			X20CrMoV12-1 1.4922	X10CrMoVNb9-1 1.4903		
13CrMo4 4 1.7335				12CrMo19-5 1.7362	X12CrMo9-1 1.7386				
620 - 460			622 - 490		629 - 470	762			
620 - 440	660	621	622	625	629 - 470	762			
TU13CD4-04 14CrMo3 15 121	15 128	TU10CD5-05	TU10CD9-10 12CrMo9-10 15 313	TUZ12CD05-05	TUZ10CD9		TUZ10CDVNb09-01		
15ChM	(12Ch1MF)								
15HM	(12HMF)								
T12 P12		T11 P11	T22 P22	T5, T5B, T5C P5, P5B, P5C	T9 P9		T91 P91	T92 P92	
STPA22		STPA23	STPA24	STPA25	STPA26		STPA28		
STBA22		STBA23	STBA24	STBA25	STBA26		STBA28		

## Seamless steel tubes for pressure equipment of fine-grained steels

Standards	Dimensional standards	Dimensional range	Dimensions				
			Tolerance D	Tolerance T	Lengths	Straightness	Tube ends
EN	10216-3	Table 5/Page 40	Hot finished: D ≤ 219,1 mm ± 1 % min ± 0,5 mm  Cold finished: ± 0,5 % min ± 0,3 mm  Delivery by $d_{min}$ a $T_{min}$ upon agreement (Page 26)	D ≤ 219,1 mm ± 12,5 % min ± 0,4 mm  ± 10 % min ± 0,2 mm	Kinds: • random • exact  Indicative values: • D < 60,3 mm 5–6 m • D ≥ 60,3 mm / T < 7,1 mm 5–6 m or 10–14 m • D ≥ 60,3 mm / T ≥ 7,1 mm 5–6 m • longer upon agreement	Permissible 0,0015.L for tube conversion to 1 m max. 3 mm	• square cut ends • free from excessive burrs • option: with beveled ends
	10305-1 (upon agreement)	Table 25/Page 69	Cold finished - precision See page 62 - 65		Exact length tolerances: * • L < 6 m 0 + 10 mm • L = 6–12 m 0 + 15 mm • L > 12 m + upon agreement – 0		
DIN	2448	Table 5/Page 40	D ≤ 100 mm ± 1 % min ± 0,5 mm D = 100–200 mm ± 1 %	D < 130 mm • T ≤ 2Tn – 10 % + 15 % • 2Tn < T < 4Tn – 10 % + 12,5 % • T > 4Tn ± 9 % D > 130 mm See page 22  Tn – basic wall thickness according to DIN 2448	Kinds: • random • fixed ± 500 mm • exact  Indicative values: • D < 60,3 mm 5–6 m • D ≥ 60,3 mm / T < 7,1 mm 5–6 m or 10–14 m • D ≥ 60,3 mm / T ≥ 7,1 mm 5–6 m • longer upon agreement	• visually straight • upon agreement	• square cut ends • free from excessive burrs • option: with beveled ends T ≥ 3,2 mm
	2391-1 (upon agreement)	Table 25/Page 69	Cold finished - precision see pages 62 - 65		Exact length tolerances: * • L ≤ 6 m 0 + 10 mm • L ≥ 3 m + 1,5 mm/m max 15 mm		

\* HF production facilities to 12,7 m + 50 mm (30 mm), over 12,7 m + 100 mm

### List of dimensional standards and technical delivery conditions standards

DIN 2391-1	Seamless precision steel tubes. Part 1: Dimensions. DIN 2448 Plain end seamless steel tubes. Dimensions.
DIN 17179	Seamless circular tubes of fine grain steel for special requirements. TDC.
EN 10 216-3	Seamless steel tubes for pressure purposes. TDC. Part 3: Non-alloy and alloy fine grain steel tubes.
DIN 2448	Seamless tubes, dimensions.

### Designation of steel according to EN:

- P – steel for pressure equipments
- 355 – minimum yield strength in N/mm<sup>2</sup>
- N – normalized or normalising formed
- NH – high temperature steel
- NL1 – low temperature steel
- NL2 – special low temperature steel

**Note:** Fine grain steel – ferritic grain size 6 or finer according to ASTM E112.

TDC standards	Steel grade			Testing and certificates		Other TDC		
	Name	Condition	Surface	Testing	Certificate	Marking	Surface protection	Packing
10216-3	P355N P460N P355NH P460NH P275NL1 P355NL1 P460NL1 P275NL2 P355NL2 P460NL2	Hot finished • at P355N and P355NH normalising formed is enough • other steels normalized designation +N Cold finished • normalized designation +N	• visually free from surface defects • adequate to production mode	Category1and2 (TC1 and TC2) • cast analysis • tensile test • flattening • drift expanding or • ring expanding • impact test • leak tightness (page 8) • dimesions • visual • NDT • material identification • optional tests upon agreement See also note at page 34	10204: • 3.1 • 3.2  See page 7	D ≤ 51 mm – label D > 51 mm – at end Data: • producer • standard • steel grade • TC (C - in steel) • cast (code) • inspector's mark • identification number Optionally: • additional marking upon agreement	• without protection • upon agreement	
17179	StE 255, 285, 355, 420, 460 W StE 255, 285, 355, 420, 460 T StE 255, 285, 355, 420, 460 E StE 255, 285, 355, 420, 460  See also page 122 /table 57	Hot finished • normalising formed • normalized Cold finished • normalized		• cast analysis • tensile test • impact test • drift expanding • NDT - upon agreement • leak tightness • visual • dimesions • other upon agreement	50049 3.1.A 3.1.B 3.1.C	Usually die stamping Small diameter - label Data: • manufacturer • steel • symbol S • inspector's mark • cast • number of tube (D over 159mm) • symbol for NDT		

### Steels grades, chemical composition and mechanical properties

Standards	Steel	Chemical composition [%]										Mechanical properties				
		C	Si	Mn	Pmax	Smax	Cr	Ni	Mo	Cu	Other	Re min MPa	Re min ksi	Rm min MPa	Rm max MPa	A5 min ksi
<b>DIN</b>																
17179	StE 255	max.0,18	max.0,40	0,50 - 1,30	0,035	0,030	max.0,30	max.0,30	max.0,08	max.0,20	Al min.0,020	255	360	480		25
	WStE 255	max.0,18	max.0,40	0,50 - 1,30	0,035	0,030	max.0,30	max.0,30	max.0,08	max.0,20	Al min.0,020	255	360	480		25
	TStE 255	max.0,16	max.0,40	0,50 - 1,30	0,030	0,025	max.0,30	max.0,30	max.0,08	max.0,20	Al min.0,020	255	360	480		25
	EStE 255	max.0,16	max.0,40	0,50 - 1,30	0,025	0,015	max.0,30	max.0,30	max.0,08	max.0,20	Al min.0,020	255	360	480		25
	StE 285	max.0,18	max.0,40	0,60 - 1,40	0,035	0,030	max.0,30	max.0,30	max.0,08	max.0,20	Al min.0,020	285	390	510		24
	WStE 285	max.0,18	max.0,40	0,60 - 1,40	0,035	0,030	max.0,30	max.0,30	max.0,08	max.0,20	Al min.0,020	285	390	510		24
	TStE 285	max.0,16	max.0,40	0,60 - 1,40	0,030	0,025	max.0,30	max.0,30	max.0,08	max.0,20	Al min.0,020	285	390	510		24
	EStE 285	max.0,16	max.0,40	0,60 - 1,40	0,025	0,015	max.0,30	max.0,30	max.0,08	max.0,20	Al min.0,020	285	390	510		24
	StE 355	max.0,20	0,10 - 0,50	0,90 - 1,65	0,035	0,030	max.0,30	max.0,30	max.0,08	max.0,20	Al min.0,020	355	490	630		22
	WStE 355	max.0,20	0,10 - 0,50	0,90 - 1,65	0,035	0,030	max.0,30	max.0,30	max.0,08	max.0,20	Al min.0,020	355	490	630		22
	TStE 355	max.0,18	0,10 - 0,50	0,90 - 1,65	0,030	0,025	max.0,30	max.0,30	max.0,08	max.0,20	Al min.0,020	355	490	630		22
EStE 355	max.0,18	0,10 - 0,50	0,90 - 1,65	0,025	0,015	max.0,30	max.0,30	max.0,08	max.0,20	Al min.0,020	355	490	630		22	
<b>EN</b>																
10216-3	P275NL1	max.0,16	max.0,40	0,50 - 1,50	0,025	0,008	max.0,30	max.0,50	max.0,08	max.0,30	V max.0,05 Nb max.0,05 Ti max.0,04 Al min.0,020 Nb +Ti +V max.0,05	275	390	530		24
	P275NL2	max.0,16	max.0,40	0,50 - 1,50	0,025	0,005	max.0,30	max.0,50	max.0,08	max.0,30		275	390	530		24
	P355N	max.0,20	max.0,50	0,90 - 1,70	0,025	0,020	max.0,30	max.0,50	max.0,08	max.0,30		355	490	650		22
	P355NH	max.0,20	max.0,50	0,90 - 1,70	0,025	0,010	max.0,30	max.0,50	max.0,08	max.0,30	V max.0,10 Nb max.0,05 Ti max.0,04 Al min.0,020 Nb +Ti +V max.0,12	355	490	650		22
	P355NL1	max.0,18	max.0,50	0,90 - 1,70	0,025	0,008	max.0,30	max.0,50	max.0,08	max.0,30		355	490	650		22
	P355NL2	max.0,18	max.0,50	0,90 - 1,70	0,025	0,005	max.0,30	max.0,50	max.0,08	max.0,30		355	490	650		22
	P460N	max.0,20	max.0,60	1,00 - 1,70	0,025	0,020	max.0,30	max.0,80	max.0,10	max.0,70		460	560	730		19
	P460NH	max.0,20	max.0,60	1,00 - 1,70	0,025	0,010	max.0,30	max.0,80	max.0,10	max.0,70	V max.0,20 Nb max.0,05 Ti max.0,04 Al min.0,020 Nb +Ti +V max.0,22	460	560	730		19
	P460NL1	max.0,20	max.0,60	1,00 - 1,70	0,025	0,008	max.0,30	max.0,80	max.0,10	max.0,70		460	560	730		19
P460NL2	max.0,20	max.0,60	1,00 - 1,70	0,025	0,005	max.0,30	max.0,80	max.0,10	max.0,70		460	560	730		19	

## Seamless boiler steel tubes for pressure equipments (low temperature)

Standards	Dimensional standards	Dimensional range	Dimensions				
			Tolerance D	Tolerance T	Lengths	Straightness	Tube ends
EN	10216-4	Table 5/Page 40	Hot finished: D ≤ 219,1 mm ±1 % min ±0,5 mm  Cold finished: ±0,5 % min ±0,3 mm	D ≤ 219,1 mm ±12,5 % min ±0,4 mm  ±10 % min ±0,2 mm	Kinds: • random • exact  Informative values: • D < 60,3 mm 5–6 m • D ≥ 60,3 mm / T < 7,1 mm 5–6 m or 10–14 m • D ≥ 60,3 mm / T ≥ 7,1 mm 5–6 m • longer upon agreement  Exact length tolerances: * • L < 6 m 0 +10 mm • L = 6–12 m 0 +15 mm • L > 12 m + upon agreement – 0	Permissible 0,0015.L for tube conversion to 1 m max. 3 mm	• square cut ends • free from excessive burrs • option: with beveled ends
	10305-1 upon agreement	Table 25/Page 69	Cold finished - precision See page 62 a 65				
DIN	2448	Table 5/Page 40	D ≤ 100 mm ±1 % min ±0,5 mm D = 100–200 mm ±1 %	D < 130 mm • T ≤ 2Tn –10 % +15 % • 2Tn < T < 4Tn –10 % +12,5 % • T > 4Tn ±9 %  Tn – basic wall thickness according to DIN 2448	Kinds: • random • fixed ±500 mm • exact Informative values: • D < 60,3 mm 5–6 m • D ≥ 60,3 mm / T < 7,1 mm 5–6 m or 10–14 m • D ≥ 60,3 mm / T ≥ 7,1 mm 5–6 m • longer upon agreement  Precise length tolerances: like EN	• visually straight • upon agreement	
	2391-1 upon agreement	Table 25/Page 69	Cold finished - precision See page 62 a 65				
BS	3600	Table 5/Page 40	Hot finished: ±1 % min ±0,5 mm  Cold finished: ±0,75 % min ±0,5 mm	≤ 3 %D ±15 % 3–10 %D ±12,5 %  ±7,5 %	• random • exact with tolerances: * L ≤ 6 m 0 +6 mm L > 6 m 1,5 mm/m, max 12 mm		
NFA	49-215		D ≤ 20 mm ±0,10 mm D = 20–38 mm ±0,15 mm D = 38–50 mm ±0,25 mm D > 50 mm ±0,30 mm	±9 % min ±0,20 mm upon agreement 0 +18%	Exact with tolerances: * L ≤ 6 m 0 +3 mm L = 6–9 m 0 +4,5 mm L = 9–12 m 0 +6 mm L = 12–15 m 0 +7,5 mm L = 15–18 m 0 +9 mm	• Locally 3 mm/m • Total: L < 4 m 2 mm/m L = 4–6 m 8 mm/m L > 6 m 8 mm +1 mm/m	• square cut ends • free from excessive burrs

\* HF production facilities to 12,7 m + 50 mm (30 mm), over 12,7 m + 100 mm

### List of dimensional standards and technical delivery conditions standards

- EN 10 216 - 4 Seamless steel tubes for pressure purposes. TDC.  
Part 4: Non-alloy and alloy steel tubes with specified low temperature properties.
- DIN 2391-1 Seamless precision steel tubes. Part 1: Dimensions.
- DIN 2448 Plain end seamless steel tubes. Dimensions.
- DIN 17173 Seamless circular steel tubes for low temperatures. TDC.
- DIN 28180 Seamless steel tubes for tubular heat exchangers. Dimensions, tolerances, materials.
- BS 3600 Dimension and masses per unit length of welded and seamless steel pipes and tubes for pressure purposes.
- BS 3603 Carbon and alloy steel pipes and tubes with specified low temperature properties for pressure purposes.
- NFA 49-215 Seamless tubes for ferritic non alloy and alloy steel heat exchangers. Dimensions. TDC.

TDC standards	Name	Steel grade		Testing and certificates		Other TDC		
		Condition	Surface	Testing	Certificate	Marking	Surface protection	Packing
10216-4	P215NL P265NL	+ N + N Normalized Conditions valid or both methods: Hot finished Cold finished	• visually free from surface defects • adequate to production mode	Category TC1 and TC2 • cast analysis • tensile test • flattening • drift expanding or • ring expanding • impact test (by dimension) • leak tightness (page 8) • dimensions • visual • NDT-to TC2 (page 8) • material identification • optional tests upon agreement	10204: • 3.1 • 3.2  See page 7	D ≤ 51 mm - label D > 51 mm - at end Data • producer • standard • steel grade • TC (C - in steel) • cast (code) • inspector's mark • identification number Optionally: • additional marking upon agreement	• without protection • upon agreement	
17173	TTSt35N	N V (N)  V – quenched (quenching can be replaced with normalization)  Conditions valid for both methods: Hot finished Cold finished		Tests according to EN	50049 3.1.A 3.1.B 3.1.C			
3603	430LT	Hot finished • normalising formed (HF) • normalized (N) Cold finished • normalized (N)		• cast analysis • visual • tensile test • flattening • impact test • Cat.1 - ultrasonic • Cat.2 - leak tightness • hydraulic test • eddy current	• test certification • test results			
49-215	TU 42BT	Cold finished • normalized N		• product analysis • tensile test • flattening • drift expanding • visual • dimensions • NDT • leak tightness	49-001 Typ A Typ B Typ C			



### Designation of steel for low temperature according to EN:

P – steel for pressure equipments

215 – minimum yield strength in N/mm<sup>2</sup>

N – normalized or normalising formed

L – low temperature steel

Alloy steels are designated according to the chemical composition - see page 9

### Test category:

Non alloy steels - TC1 or TC2 upon agreement in order

Alloy steels - TC2 only

## Seamless steel tubes for pressure equipments for low temperature

Standards	Dimensional standards	Dimensional range	Dimensions				
			Tolerance D	Tolerance T	Lengths	Straightness	Tube ends
UNI	4991	Table 5/Page 40	Hot finished: D ≤ 51 mm ±0,5 mm D > 51 mm ±1 %  Cold finished: D ≤ 25 mm ±0,25 mm D = 25–51 mm ±0,35 mm D > 51 mm ±0,75 % Weight –8 % +10 %	D ≤ 323,9 mm ±12,5 % (–17,5 %)  Cold finished: di ≤ 7 mm ±12 % (–14 %) min ±0,10 mm di > 7 mm ±10 % (–12 %)	• random • exact with tolerances: * L ≤ 6 m 0 +10 mm L > 6 m 0 +15 mm	• straightened 3 mm/m • flat straightened –1,5mm/m	• square cut ends • free from excessive burrs • option: with beveled ends
STN ČSN	42 5715 42 5716	Table 5/Page 40	42 5715 D ≤ 219 mm ±1,25 % min ±0,5 mm	D < 219 mm, T < 20 mm –15 % +12,5 %	Exact length tolerances: * 0 +15 mm Multiple: +5 mm on cut, max. +50 mm	• straightened 3 mm/m • flat straightened –1,5mm/m Marking: .+1 .+2 za RN	
			42 5716 D ≤ 219 mm ±1% min ±0,5 mm	±12,5 %			
	42 6710 42 6711	Table 23/Page 68	42 6710 ±1% min ±0,4 mm	T ≤ 3 mm –10 % +15 % T > 3 mm –10 % +12 %			
			42 6711 see precision tubes				
ANSI ASME	B 36.10	Table 7/Page 44	See table 8, page 45		See page 30	Vizuálne rovné	• square cut ends • free from excessive burrs
ASTM ASME	A334 SA-334	Table 9/Page 46	See tables 10 and 11, page 47		See page 30		
ANSI	B 36.10	Table 7/Page 44	See table 8, page 45		See page 28		

\* HF production facilities to 12,7 m + 50 mm (30 mm), over 12,7 m + 100 mm

### List of dimensional standards and technical delivery conditions standards

UNI 4991	Seamless and welded steel tubes with plain ends. Dimensions.
UNI 5949	Special unalloyed and alloyed steel seamless tubes with low temperature impact test.
STN 42 0165	ČSN 42 0165 Sheets and pipes of ferritic – perlite steel with guaranteed impact properties at low temperatures. TDC.
STN 42 5715	ČSN 42 5715 Hot formed seamless steel tubes. Dimensions.
STN 42 5716	ČSN 42 5716 Hot formed seamless steel tubes with smaller tolerances. Dimensions.
STN 42 6710	ČSN 42 6710 Cold drawn seamless tubes with normal tolerances from steel class 11 – 16. Dimensions.
STN 42 6711	ČSN 42 6711 Precision seamless steel tubes. Dimensions.
ANSI/ASME B 36.10	Welded and seamless wrought steel pipe. Dimensions.
ASTM A333	Seamless and welded steel pipe for low-temperature service. TDC.
ASTM A334	Seamless and welded carbon and alloy-steel tubes for low-temperature service. TDC.
ASTM A450	General requirements for carbon, ferritic alloy and austenitic alloy steel tubes. TDC.
ASTM A524	Seamless carbon steel pipe for atmospheric and lower temperatures. TDC.
ASTM A530	General requirements for specialized carbon and alloy steel pipe. TDC.
ASTM A999	General requirements for alloy and stainless steel pipe.
ASTM A1016	General requirements for ferritic alloy steel, austenitic alloy steel and stainless steel tubes.
ISO 9329-3	Seamless steel tubes for pressure purposes. TDC. Part 3: Non-alloy and alloy steel tubes with specified low temperature properties.



TDC standards	Steel grade			Testing and certificates		Other TDC		
	Name	Condition	Surface	Testing	Certificate	Marking	Surface protection	Packing
5949	C15 C20	Hot finished Cold finished • normalized (both conditions)	• visually free from surface defects • adequate to production mode				• without • upon agreement	• bundles 300 – 3500 kg, bundled with steel strips • other upon agreement
42 0165	11 369 11 419 11 448 11 449 11 503	Hot finished Cold finished • normalized (both conditions) .1 behind steel grade	.0+ scaled .1+ pickled (Cold finished) .2+ free of scales .9+ special agreement (first number behind DS)	• visual • tensile test .+2, .+3, .+4 • impact test (dimensions) • flattening .+3, .+4 • expansion test .+4 • leak tightness .+3, .+4 • NDT .+4 • chemical analysis • upon agreement .+9	42 0165 • 6+ test certificate • 7+ customer inspection • 9+ special arrangement + = group (kind) of test	• colored according to 42 0010 • tested NDT D < 70 mm - label on bundle See STN at page 29		
A333 (A999) SA-333 SA-999	Grade 1 Grade 6	Hot finished Cold finished • normalized (both conditions)		• product analysis • tensile test • grain size • impact test • flattening	A999	See page 31 for A999		
A334 (A1016) SA-334 SA-1016	Grade 1 Grade 6	Hot finished Cold finished • normalized in furnace (both conditions)		• leak tightness - hydrostatic pressure or NDT according to E 213 or E309	A1016	See page 31 for A1016		
A524 (A530) SA-524	Grade II			• visual • hardness (A334)	A530	See page 31 for A999		

## Steels grades, chemical composition and mechanical properties

Standards	Steel	Chemical composition [%]										Mechanical properties					
		C	Si	Mn	Pmax	Smax	Cr	Ni	Mo	Cu	Other	Re min MPa	Re min ksi	Rm min MPa	Rm max MPa	A5 min ksi	A5 min %
<b>STN, CSN</b>																	
	11 369	max.0,14	max.0,35	max.0,80	0,040	0,040	max.0,30	max.0,30		max.0,30	Al min.0,020	226		353	441		
	11 419	max.0,20	max.0,35	max.0,80	0,040	0,040	max.0,30	max.0,30		max.0,30	Al min.0,020	255		400	490		
	11 448	max.0,20	max.0,40	max.1,30	0,035	0,035	max.0,30	max.0,20		max.0,30		275		430	580		22
	11 449	max.0,15	max.0,40	max.1,50	0,035	0,035	max.0,30	max.0,20		max.0,30	Al min.0,020	295		430	530		22
	11 503	max.0,18	max.0,55	max.1,60	0,035	0,035	max.0,30	max.0,30		max.0,30	Al min.0,015	355		490	630		22
<b>ASTM</b>																	
A 333	Grade 1	max.0,30		0,40 - 1,06	0,025	0,025						205	30	380		55	35
	Grade 6	max.0,30	min. 0,10	0,29 - 1,06	0,025	0,025						240	35	415		60	30
A 334	Grade 1	max.0,30		0,40 - 1,06	0,025	0,025						205	30	380		55	35
	Grade 6	max.0,30	min. 0,10	0,29 - 1,06	0,025	0,025						240	35	415		60	30
A 524		max.0,21	0,10 - 0,40	0,90 - 1,35	0,035	0,035						240	35	414	586	60	30
<b>DIN</b>																	
17173	TT St 35N	max.0,17	max.0,35	min.0,40	0,030	0,025					Al min.0,020	225		340	460		25
<b>BS</b>																	
3603	430 LT	max.0,20	max.0,35	0,60 - 1,20	0,035	0,035					Al min.0,020	275		430	570		22
<b>NFA</b>																	
49-215	TU 42BT	max.0,22	max.0,40	max.1,15	0,040	0,040						235		410	510		23
<b>EN</b>																	
10216-4	P215NL	max.0,15	max.0,35	0,40 - 1,20	0,030	0,010	max.0,30	max.0,30	max.0,08	max.0,30	V max.0,020 Nb max.0,010 Ti max.0,040 Al min.0,020	215		360	480		25
	P265NL	max.0,20	max.0,40	0,60 - 1,40	0,030	0,010	max.0,30	max.0,30	max.0,08	max.0,30		265		410	570		24
<b>UNI</b>																	
5949	C15	max.0,15	0,15 - 0,35	max.1,00	0,035	0,035						220		350	500		28
	C20	max.0,20	0,15 - 0,35	max.1,00	0,035	0,035						250		450	600		24

**Dimensions and weight of seamless steel tubes according to standard EN 10220**

**Table 5**

Outside diameter D [mm]			Wall thickness [mm]															
			0,5	0,6	0,8	1	1,2	1,4	1,6	1,8	2	2,3	2,6	2,9	3,2	3,6	4	4,5
series 1	series 2	series 3	Tube weight [kg/m]															
10,2			0,120	0,142	0,185	0,227	0,266	0,304	0,339	0,373	0,404	0,448	0,487					
	12,0		0,142	0,169	0,221	0,271	0,320	0,366	0,410	0,453	0,493	0,550	0,603	0,651	0,694			
	12,7		0,150	0,179	0,235	0,289	0,340	0,390	0,438	0,484	0,528	0,590	0,648	0,701	0,750			
13,5			0,160	0,191	0,251	0,308	0,364	0,418	0,470	0,519	0,567	0,635	0,699	0,758	0,813	0,879		
	14,0		0,166	0,198	0,260	0,321	0,379	0,435	0,489	0,542	0,592	0,664	0,731	0,794	0,852	0,923		
	16,0		0,191	0,228	0,300	0,370	0,438	0,504	0,568	0,630	0,691	0,777	0,859	0,937	1,01	1,10	1,18	
17,2			0,206	0,246	0,324	0,400	0,474	0,546	0,616	0,684	0,750	0,845	0,936	1,02	1,10	1,21	1,30	1,41
	18,0		0,216	0,257	0,339	0,419	0,497	0,573	0,647	0,719	0,789	0,891	0,987	1,08	1,17	1,28	1,38	1,50
	19,0		0,228	0,272	0,359	0,444	0,527	0,608	0,687	0,764	0,838	0,947	1,05	1,15	1,25	1,37	1,48	1,61
	20,0		0,240	0,287	0,379	0,469	0,556	0,642	0,726	0,808	0,888	1,00	1,12	1,22	1,33	1,46	1,58	1,72
21,3			0,256	0,306	0,404	0,501	0,595	0,687	0,777	0,866	0,952	1,08	1,20	1,32	1,43	1,57	1,71	1,86
	22,0		0,265	0,317	0,418	0,518	0,616	0,711	0,805	0,897	0,986	1,12	1,24	1,37	1,48	1,63	1,78	1,94
	25,0			0,361	0,477	0,592	0,704	0,815	0,923	1,03	1,13	1,29	1,44	1,58	1,72	1,90	2,07	2,28
	25,4				0,485	0,602	0,716	0,829	0,939	1,05	1,15	1,31	1,46	1,61	1,75	1,94	2,11	2,32
26,9					0,515	0,639	0,761	0,880	0,998	1,11	1,23	1,40	1,56	1,72	1,87	2,07	2,26	2,49
	30,0				0,576	0,715	0,852	0,987	1,12	1,25	1,38	1,57	1,76	1,94	2,11	2,34	2,56	2,83
	31,8					0,760	0,906	1,05	1,19	1,33	1,47	1,67	1,87	2,07	2,26	2,50	2,74	3,03
	32,0					0,765	0,911	1,06	1,20	1,34	1,48	1,68	1,89	2,08	2,27	2,52	2,76	3,05
33,7						0,806	0,962	1,12	1,27	1,42	1,56	1,78	1,99	2,20	2,41	2,67	2,93	3,24
	35,0					0,838	1,00	1,16	1,32	1,47	1,63	1,85	2,08	2,30	2,51	2,79	3,06	3,38
	38,0					0,912	1,09	1,26	1,44	1,61	1,78	2,02	2,27	2,51	2,75	3,05	3,35	3,72
	40,0					0,962	1,15	1,33	1,52	1,70	1,87	2,14	2,40	2,65	2,90	3,23	3,55	3,94
42,4									1,61	1,80	1,99	2,27	2,55	2,82	3,09	3,44	3,79	4,21
	44,5								1,69	1,90	2,10	2,39	2,69	2,98	3,26	3,63	4,00	4,44
48,3									1,84	2,06	2,28	2,61	2,93	3,25	3,56	3,97	4,37	4,86
	51,0								1,95	2,18	2,42	2,76	3,10	3,44	3,77	4,21	4,64	5,16
	54,0								2,07	2,32	2,56	2,93	3,30	3,65	4,01	4,47	4,93	5,49
	57,0								2,19	2,45	2,71	3,10	3,49	3,87	4,25	4,74	5,23	5,83
60,3									2,32	2,60	2,88	3,29	3,70	4,11	4,51	5,03	5,55	6,19
	63,5								2,44	2,74	3,03	3,47	3,90	4,33	4,76	5,32	5,87	6,55
	70,0								2,70	3,03	3,35	3,84	4,32	4,80	5,27	5,90	6,51	7,27
	73,0								2,82	3,16	3,50	4,01	4,51	5,01	5,51	6,16	6,81	7,60
76,1									2,94	3,30	3,65	4,19	4,71	5,24	5,75	6,44	7,11	7,95
	82,5										3,97	4,55	5,12	5,69	6,26	7,00	7,74	8,66
88,9											4,29	4,91	5,53	6,15	6,76	7,57	8,38	9,37
	101,6										4,91	5,63	6,35	7,06	7,77	8,70	9,63	10,78
	108,0										5,23	6,00	6,76	7,52	8,27	9,27	10,26	11,49
114,3													7,16	7,97	8,77	9,83	10,88	12,19
	(121)												7,60	8,45	9,30	10,42	11,54	12,93
	127,0																12,13	13,59
	133,0																12,73	14,26
139,7																		
Wall thickness [mm]	0,5	0,6	0,8	1	1,2	1,4	1,6	1,8	2	2,3	2,6	2,9	3,2	3,6	4	4,5		

Notes to Table 5:

- The dimensions of steel tubes in this table are taken from the applicable European standards EN 10220 – Seamless and welded steel tubes – Dimensions and masses per unit length. This standard replaced previously existing national standards DIN, BS, NF A and other standards. The dimensions represent the current production program of steel tubes from Podbrezová (other than **precision tubes**, whose dimensions are listed in other tables for precision tubes). Outside diameters are in the standard divided into three series. Column 1 shows the so-called preferred dimensions (series 1), to be used for piping systems. For pipelines made from pipes of series 1 is produced all necessary accessories (fittings, valves, etc.). The dimensions of this series correspond **approximately** pipe size according standards ANSI and API 5L, where the outside unit SI are also used inch (US Customer Units). (See also section 6).
- Depending on the size of the outside diameters, wall thickness and their combinations are the tubes (final dimensions) produced by hot forming (hot finished by rolling) or by end forming (cold finished by drawing).  
Besides technological possibilities tube production method is also affected by the requirements of customers on the technical parameters of tubes.
- Method of production (hot finished or cold finished) affects the price of tubes. Price matters but not covered by this guide.
- Informative – hot finished tubes are supplied from Podbrezová from the outside diameter D ≥ 26,9 mm and wall thickness T ≥ 2,6 mm. These tubes in

													Outside diameter
5	5,4	5,6	6,3	7,1	8	8,8	10	11	12,5	14,2	16,0		D [mm]
													10,2
													12,0
													12,7
													13,5
													14,0
													16,0
													17,2
													18,0
													19,0
1,73													20,0
1,85													21,3
2,01	2,12												22,0
2,10	2,21												25,0
2,47	2,61	2,68											25,4
2,52	2,66	2,73											26,9
2,70	2,86	2,94											30,0
3,08	3,28	3,37	3,68										31,8
3,30	3,52	3,62	3,96	4,33									32,0
3,33	3,54	3,65	3,99	4,36									33,7
3,54	3,77	3,88	4,26	4,66									35,0
3,70	3,94	4,06	4,46	4,89									38,0
4,07	4,34	4,47	4,93	5,41	5,92								40,0
4,32	4,61	4,75	5,24	5,76	6,31								42,4
4,61	4,93	5,08	5,61	6,18	6,79	7,29							44,5
4,87	5,21	5,37	5,94	6,55	7,20	7,75	8,51						48,3
5,34	5,71	5,90	6,53	7,21	7,95	8,57	9,45						51,0
5,67	6,07	6,27	6,94	7,69	8,48	9,16	10,10						54,0
6,04	6,47	6,68	7,41	8,21	9,08	9,81	10,90						57,0
6,41	6,87	7,10	7,88	8,74	9,67	10,50	11,60	12,48	13,72				60,3
6,82	7,31	7,55	8,39	9,32	10,32	11,18	12,40	13,37	14,74				63,5
7,21	7,74	8,00	8,89	9,88	10,95	11,87	13,20	14,24	15,72				70,0
8,01	8,60	8,89	9,90	11,01	12,23	13,28	14,80	16,01	17,73	19,33			73,0
8,38	9,00	9,31	10,4	11,54	12,82	13,93	15,50	16,82	18,65	20,37			76,1
8,77	9,42	9,74	10,8	12,08	13,44	14,61	16,30	17,66	19,61	21,44	23,71		82,5
9,56	10,30	10,62	11,84	13,20	14,70	15,99	17,88	19,40	21,58	23,65	26,24		88,9
10,30	11,10	11,50	12,83	14,32	15,96	17,38	19,46	21,13	23,55	25,86	28,77		101,6
11,91	12,80	13,26	14,81	16,50	18,47	20,14	22,59	24,58	27,47	30,24	33,78		108,0
12,70	13,70	14,14	15,8	17,67	19,73	21,53	24,17	26,31	29,44	32,45	36,30		114,3
13,48	14,50	15,01	16,8	18,77	20,97	22,90	25,72	28,02	31,38	34,63	38,79		121,0
14,30	15,39	15,94	17,82	19,94	22,29	24,35	27,37	29,84	33,45	36,94	41,43		127,0
15,04	16,20	16,77	18,8	20,99	23,48	25,65	28,85	31,47	35,30	39,01	43,80		133,0
15,78	17,00	17,59	19,7	22,04	24,66	26,95	30,33	33,10	37,15	41,09	46,17		139,7
			20,7	23,22	25,98	28,41	31,99	34,91	39,21	43,40	48,81		
5	5,4	5,6	6,3	7,1	8	8,8	10	11	12,5	14,2	16		

Tolerances depend on method of manufacture, steel grade and heat treatment.

Tolerances [mm]		
Outside diameter	Tolerance of outside diameter	Tolerance of wall thickness
D ≤ 219,1	±1% alebo ±0,5 mm*	±12,5 % alebo ±0,4 mm*

\* bigger value is applied  
see also values presented in national standards

Dimension tolerances according to ISO 1129	
Outside diameter	Wall thickness
D <sub>2</sub> = ±1 %, min ±0,50mm	T <sub>2</sub> = ±12,5 %, min ±0,40 mm
D <sub>3</sub> = ±0,75 %, min ±0,30mm	T <sub>3</sub> = ±10 %, min ±0,20 mm
D <sub>4</sub> = ±0,50 %, min ±0,10mm	T <sub>4</sub> = ±7,5 %, min ±0,15 mm
	T <sub>5</sub> = ±5 %, min ±0,10 mm

 cold drawn

 hot rolled

 dimensions according to standard EN 10210-2

 standard wall thickness of specific outside diameter according to DIN 2448

the table are highlighted in color. Production border dimensions of tubes (eg. tubes with thick walls) upon agreement. Other dimensions and precision tubes are produced by cold forming (cold drawing).

- Russian standards and currently already replaced standards ČSN and STN also contain the tubes with other nominal dimensions than those listed in table. The supply of these tubes is possible by agreement. It is the outside diameter 28, 76, 89, 102, 114, 121 and 140 mm and wall thickness 2,5 / 2,8 / 3 / 3,5 / 5,5 / 6 / 6,5 / 7 / 7,5 / 8,5 / 9 / 9,5 / 12 mm.
- Dimensions of steel tubes according to U.S. standards (Tubes and Pipe), API standards, pipes for threading and tubes and pipe supplied by Japanese standard JIS are listed in other tables of dimensions.
- The professional literature also contains the standards ISO. For dimensions and weight of steel tubes with plain ends valid standard ISO 4200, system of tolerances is in standard ISO 5252. ISO 1129 contains dimensions, tolerances and weight of steel tubes for boilers, superheaters and heat exchangers.
- EN standards valid for individual types and groups of steel tubes (eg. tubes for pressure equipment) also contain its own dimension table. Dimensions in them are taken from EN 10220. In the survey tables of different groups of tubes are as dimensional standards given numbers of EN valid for given group of tubes (eg. EN 10216-1).

# Hot rolled tubes - dimensions according to GOST 8732 and TU

Table 6

Outside diameter [mm]	Wall thickness [mm]															
	2,5	2,6	2,8	3	3,2	3,5	4	4,5	5	5,5	6	6,5*	7	7,5*	8	
	Tube weight [kg/m]															
20	1,08	1,12	1,19	1,26	1,33	1,42	1,58									
21,3	1,16	1,2	1,28	1,35	1,43	1,54	1,71									
22	1,2	1,24	1,33	1,41	1,48	1,6	1,78									
25	1,39	1,44	1,53	1,63	1,72	1,86	2,07									
26,9	1,5	1,56	1,66	1,77	1,87	2,02	2,26	2,49	2,7							
28	1,57	1,63	1,74	1,85	1,96	2,12	2,37	2,61	2,84							
30	1,7	1,76	1,88	2	2,12	2,29	2,57	2,83	3,08	3,32	3,55					
31,8	1,8	1,87	2	2,13	2,26	2,44	2,74	3,03	3,31	3,57	3,81	4,06	4,28			
32	1,82	1,89	2,02	2,15	2,27	2,46	2,76	3,05	3,33	3,59	3,85	4,09	4,32			
33,7	1,92	1,99	2,13	2,27	2,41	2,61	2,93	3,24	3,54	3,83	4,1	4,36	4,61			
35	2	2,08	2,22	2,37	2,51	2,72	3,06	3,39	3,7	4	4,29	4,57	4,83			
38	2,19	2,27	2,43	2,59	2,75	2,98	3,35	3,72	4,07	4,41	4,74	5,05	5,35	5,64	5,92	
40	2,31	2,4	2,57	2,74	2,9	3,15	3,55	3,94	4,32	4,68	5,03	5,37	5,7	6,01	6,31	
42	2,44	2,53	2,71	2,89	3,06	3,32	3,75	4,16	4,56	4,95	5,33	5,69	6,04	6,38	6,71	
42,4	2,46	2,55	2,73	2,92	3,09	3,36	3,79	4,21	4,61	5,01	5,39	5,76	6,11	6,46	6,79	
44,5	2,59	2,69	2,88	3,07	3,26	3,54	4	4,44	4,87	5,29	5,7	6,09	6,47	6,84	7,2	
45	2,62	2,72	2,91	3,11	3,3	3,58	4,04	4,5	4,93	5,36	5,77	6,17	6,56	6,94	7,3	
48	2,8	2,91	3,12	3,33	3,54	3,84	4,34	4,83	5,3	5,77	6,22	6,65	7,08	7,49	7,89	
48,3	2,82	2,93	3,14	3,35	3,56	3,87	4,37	4,86	5,34	5,8	6,26	6,7	7,13	7,55	7,95	
50		3,04	3,26	3,48	3,69	4,01	4,54	5,05	5,55	6,04	6,51	6,9	7,42	7,86	8,29	
51		3,1	3,33	3,55	3,77	4,1	4,64	5,16	5,67	6,17	6,66	7,13	7,6	8,05	8,48	
54		3,3	3,54	3,77	4,01	4,36	4,93	5,49	6,04	6,58	7,1	7,61	8,11	8,6	9,08	
55		3,36	3,6	3,85	4,09	4,45	5,03	5,6	6,17	6,71	7,25	7,77	8,29	8,79	9,27	
57			3,74	4	4,25	4,62	5,23	5,83	6,41	6,99	7,55	8,1	8,63	9,16	9,67	
60			3,95	4,22	4,48	4,88	5,52	6,16	6,78	7,39	7,99	8,58	9,15	9,71	10,26	
60,3			3,97	4,24	4,51	4,9	5,55	6,19	6,82	7,43	8,04	8,62	9,2	9,77	10,32	
63,5			4,19	4,48	4,76	5,18	5,87	6,55	7,21	7,87	8,51	9,14	9,75	10,36	10,95	
68			4,5	4,81	5,11	5,57	6,31	7,05	7,77	8,48	9,17	9,86	10,53	11,19	11,84	
70			4,64	4,96	5,27	5,74	6,51	7,27	8,02	8,75	9,47	10,18	10,88	10,88	12,23	
73			4,85	5,18	5,51	6	6,81	7,6	8,39	9,16	9,91	10,66	11,39	10,66	12,82	
76			5,06	5,4	5,75	6,26	7,1	7,94	8,76	9,56	10,36	11,14	11,91	11,14	13,42	
82,5					6,26	6,82	7,74	8,66	9,56	10,44	11,32	12,18	13,03	13,87	14,7	
83					6,3	6,86	7,79	8,71	9,62	10,51	11,39	12,26	13,12	13,96	14,8	
89					6,77	7,38	8,39	9,38	10,36	11,33	12,28	13,23	14,16	15,07	15,98	
95						7,9	8,98	10,04	11,1	12,14	13,17	14,19	15,19	16,18	17,16	
102						8,5	9,67	10,82	11,96	13,09	14,21	15,31	16,4	17,48	18,55	
104							8,67	9,86	11,04	12,21	13,36	14,5	15,63	16,75	17,85	18,94
108							9,02	10,26	11,49	12,7	13,9	15,09	16,27	17,44	18,59	19,73
114							9,54	10,851	12,15	13,44	14,72	15,98	17,23	18,47	19,7	20,91
121							10,14	11,54	12,93	14,3	15,67	17,02	18,35	19,68	20,99	22,29
127							10,66	12,13	13,6	15,04	16,48	17,9	19,32	20,72	22,1	23,48
133							11,18	12,73	14,26	15,78	17,29	18,79	20,28	21,75	23,21	24,66
140													21,4	22,96	24,51	26,04

\* dimension from TU 14-3R-55-2001



# Dimensions and weight of seamless tubes according to standard ANSI / ASME B36.10M

**Table 7**

API Spec 5L; EN ISO 3183; A/SA-53; A/SA-106 in connection with A/SA 530; A/SA-335 (A/SA-333) in connection with A/SA 999"

NPS	Outside diameter		Wall thickness		Schedule No	Weight class	DN	Weight		API Spec 5L	A/SA-53
	[inch]	[mm]	[inch]	[mm]				[lbs/ft]	[kg/m]		
1/8	0.405	10,3	0.049	1,24	10	...	6	0.19	0,28	-	
1/8	0.405	10,3	0.057	1,45	30	...	6	0.21	0,32	-	
1/8	0.405	10,3	0.068	1,73	40	STD	6	0.24	0,37	API	√
1/8	0.405	10,3	0.095	2,41	80	XS	6	0.31	0,47	-	√
1/4	0.540	13,7	0.065	1,65	10	...	8	0.33	0,49	-	
1/4	0.540	13,7	0.073	1,85	30	...	8	0.36	0,54	API	
1/4	0.540	13,7	0.088	2,24	40	STD	8	0.42	0,63	API	√
1/4	0.540	13,7	0.119	3,02	80	XS	8	0.54	0,80	-	√
3/8	0.675	17,1	0.065	1,65	10	...	10	0.42	0,63	-	
3/8	0.675	17,1	0.073	1,85	30	...	10	0.47	0,70	-	
3/8	0.675	17,1	0.091	2,31	40	STD	10	0.57	0,84	API	√
3/8	0.675	17,1	0.126	3,20	80	XS	10	0.74	1,10	-	√
1/2	0.840	21,3	0.065	1,65	5	...	15	0.54	0,80	-	
1/2	0.840	21,3	0.083	2,11	10	...	15	0.67	1,00	-	
1/2	0.840	21,3	0.095	2,41	30	...	15	0.76	1,12	API	
1/2	0.840	21,3	0.109	2,77	40	STD	15	0.85	1,27	API	√
1/2	0.840	21,3	0.147	3,73	80	XS	15	1.09	1,62	-	√
1/2	0.840	21,3	0.188	4,78	160	...	15	1.31	1,95	-	√
3/4	1.050	26,7	0.065	1,65	5	...	20	0.69	1,03	-	
3/4	1.050	26,7	0.083	2,11	10	...	20	0.86	1,28	API	
3/4	1.050	26,7	0.095	2,41	30	...	20	0.97	1,44	API	
3/4	1.050	26,7	0.113	2,87	40	STD	20	1.13	1,69	API	√
3/4	1.050	26,7	0.154	3,91	80	XS	20	1.47	2,20	API	√
3/4	1.050	26,7	0.219	5,56	160	...	20	1.94	2,90	API	√
1	1.315	33,4	0.065	1,65	5	...	25	0.87	1,29	-	
1	1.315	33,4	0.109	2,77	10	...	25	1.41	2,09	API	
1	1.315	33,4	0.114	2,9	30	...	25	1.46	2,18	API	
1	1.315	33,4	0.133	3,38	40	STD	25	1.68	2,50	API	√
1	1.315	33,4	0.179	4,55	80	XS	25	2.17	3,24	API	√
1	1.315	33,4	0.250	6,35	160	...	25	2.84	4,29	API	√
1 1/4	1.660	42,2	0.065	1,65	5	...	32	1.11	1,65	-	
1 1/4	1.660	42,2	0.109	2,77	10	...	32	1.81	2,69	API	
1 1/4	1.660	42,2	0.117	2,97	30	...	32	1.93	2,87	API	
1 1/4	1.660	42,2	0.140	3,56	40	STD	32	2.27	3,39	API	√
1 1/4	1.660	42,2	0.191	4,85	80	XS	32	3.00	4,47	API	√
1 1/4	1.660	42,2	0.250	6,35	160	...	32	3.76	5,61	API	√
1 1/2	1.900	48,3	0.065	1,65	5	...	40	1.28	1,90	-	
1 1/2	1.900	48,3	0.109	2,77	10	...	40	2.09	3,11	API	
1 1/2	1.900	48,3	0.125	3,18	30	...	40	2.37	3,53	API	
1 1/2	1.900	48,3	0.145	3,68	40	STD	40	2.72	4,05	API	√
1 1/2	1.900	48,3	0.200	5,08	80	XS	40	3.63	5,41	API	√
1 1/2	1.900	48,3	0.281	7,14	160	...	40	4.86	7,25	API	√
1 1/2	1.900	48,3	0.400	10,15	...	XXS	40	6.41	9,55	...	
2	2.375	60,3	0.065	1,65	5	...	50	1.61	2,39	-	
2	2.375	60,3	0.083	2,11	...	...	50	2.03	3,03	API	
2	2.375	60,3	0.109	2,77	10	...	50	2.64	3,93	API	
2	2.375	60,3	0.125	3,18	30	...	50	3.00	4,48	API	
2	2.375	60,3	0.141	3,58	...	...	50	3.36	5,01	API	
2	2.375	60,3	0.154	3,91	40	STD	50	3.65	5,44	API	√
2	2.375	60,3	0.172	4,37	...	...	50	4.05	6,03	API	
2	2.375	60,3	0.188	4,78	...	...	50	4.40	6,54	API	
2	2.375	60,3	0.218	5,54	80	XS	50	5.03	7,48	API	√
2	2.375	60,3	0.250	6,35	...	...	50	5.68	8,45	API	
2	2.375	60,3	0.281	7,14	...	...	50	6.29	9,36	API	
2	2.375	60,3	0.344	8,74	160	...	50	7.47	11,11	API	√
2	2.375	60,3	0.436	11,07	...	XXS	50	9.04	13,44	API	√
2 1/2	2.875	73,0	0.038	2,11	5	...	65	2.48	3,69	API-light	
2 1/2	2.875	73,0	0.109	2,77	...	...	65	3.22	4,80	API-light	
2 1/2	2.875	73,0	0.120	3,05	10	...	65	3.53	5,26	API-light	
2 1/2	2.875	73,0	0.125	3,18	...	...	65	3.67	5,48	API-light	
2 1/2	2.875	73,0	0.141	3,58	...	...	65	4.12	6,13	API-light	
2 1/2	2.875	73,0	0.156	3,96	...	...	65	4.53	6,74	API	
2 1/2	2.875	73,0	0.172	4,37	...	...	65	4.97	7,40	API	
2 1/2	2.875	73,0	0.188	4,78	30	...	65	5.40	8,04	API	
2 1/2	2.875	73,0	0.203	5,16	40	STD	65	5.80	8,63	API	√





NPS	Outside diameter		Wall thickness		Schedule No	Weight class	DN	Weight		API Spec 5L	A/SA-53
	[inch]	[mm]	[inch]	[mm]				[lbs/ft]	[kg/m]		
2 1/2	2.875	73,0	0.216	5,49	...	...	65	6.14	9,14	API	
2 1/2	2.875	73,0	0.250	6,35	...	...	65	7.02	10,44	API	
2 1/2	2.875	73,0	0.276	7,01	80	XS	65	7.67	11,41	API	√
2 1/2	2.875	73,0	0.375	9,53	160	...	65	10.02	14,92	API	√
2 1/2**	2.875	73,0	0.552	14,02	...	XXS	65	13.71	20,39	API	√
3	3.500	88,9	0.083	2,11	5	...	80	3.03	4,52	API- light	
3	3.500	88,9	0.109	2,77	...	...	80	3.95	5,88	API- light	
3	3.500	88,9	0.120	3,05	10	...	80	4.34	6,46	API- light	
3	3.500	88,9	0.125	3,18	...	...	80	4.51	6,72	API- light	√
3	3.500	88,9	0.141	3,58	...	...	80	5.06	7,53	API- light	
3	3.500	88,9	0.156	3,96	...	...	80	5.58	8,30	API	√
3	3.500	88,9	0.172	4,37	...	...	80	6.12	9,11	API	
3	3.500	88,9	0.188	4,78	30	...	80	6.66	9,92	API	√
3	3.500	88,9	0.216	5,49	40	STD	80	7.58	11,29	API	√
3	3.500	88,9	0.250	6,35	...	...	80	8.69	12,93	API	√
3	3.500	88,9	0.281	7,14	...	...	80	9.67	14,40	API	√
3	3.500	88,9	0.300	7,62	80	XS	80	10.26	15,27	API	√
3	3.500	88,9	0.438	11,13	160	...	80	14.34	21,35	API	√
3**	3.500	88,9	0.60	15,24	XXS	...	80	18.60	27,68	API	√
3 1/2**	4.000	101,6	0.083	2,11	5	...	90	3.48	5,18	API- light	
3 1/2	4.000	101,6	0.109	2,77	...	...	90	4.53	6,75	API- light	
3 1/2	4.000	101,6	0.120	3,05	10	...	90	4.98	7,41	API- light	
3 1/2	4.000	101,6	0.125	3,18	...	...	90	5.18	7,72	API- light	√
3 1/2	4.000	101,6	0.141	3,58	...	...	90	5.82	8,65	API- light	
3 1/2	4.000	101,6	0.156	3,96	...	...	90	6.41	9,54	API- light	√
3 1/2	4.000	101,6	0.172	4,37	...	...	90	7.04	10,48	API	
3 1/2	4.000	101,6	0.188	4,78	30	...	90	7.66	11,41	API	√
3 1/2	4.000	101,6	0.226	5,74	40	STD	90	9.12	13,57	API	√
3 1/2	4.000	101,6	0.250	6,35	...	...	90	10.02	14,92	API	√
3 1/2	4.000	101,6	0.281	7,14	...	...	90	11.17	16,63	API	√
3 1/2	4.000	101,6	0.318	8,08	80	XS	90	12.52	18,64	API	√
4**	4.500	114,3	0.083	2,11	5	...	100	3.92	5,84	API- light	
4	4.500	114,3	0.109	2,77	...	...	100	5.12	7,62	API- light	
4	4.500	114,3	0.120	3,05	10	...	100	5.62	8,37	API- light	
4	4.500	114,3	0.125	3,18	...	...	100	5.85	8,71	API- light	√
4	4.500	114,3	0.141	3,58	...	...	100	6.57	9,78	API- light	
4	4.500	114,3	0.156	3,96	...	...	100	7.24	10,78	API- light	√
4	4.500	114,3	0.172	4,37	...	...	100	7.96	11,85	API	
4	4.500	114,3	0.188	4,78	30	...	100	8.67	12,91	API	√
4	4.500	114,3	0.203	5,16	...	...	100	9.32	13,89	API	
4	4.500	114,3	0.219	5,56	...	...	100	10.02	14,91	API	√
4	4.500	114,3	0.237	6,02	40	STD	100	10.80	16,08	API	√
4	4.500	114,3	0.250	6,35	...	...	100	11.35	16,91	API	√
4	4.500	114,3	0.281	7,14	...	...	100	12.67	18,87	API	√
4	4.500	114,3	0.312	7,92	...	...	100	13.97	20,78	API	√
4	4.500	114,3	0.337	8,56	80	XS	100	15.00	22,32	API	√
4	4.500	114,3	0.438	11,13	120	...	100	19.02	28,32	API	√
4**	4.500	114,3	0.531	13,49	160	...	100	22.53	33,54	API	√

Delivered as cold drawn
  Hot rolled pipes
 \*\* upon agreement

**Tolerances according to ASTM A530/A530M, ASTM A999/A999M (ASME SA)**

**Table 8**

Weight	Outside diameter	Wall thickness
All standards: NPS 12 and under -3,5 % +10 % over NPS 12 -5 % +10 %  upon agreement ASTM A999: With minimum wall thickness max +16 %	$1/8 - 1 1/2"$ (10,3–48,3 mm, incl.) $-1/32$ (0.031) $+1/64$ (0.015) $-0,8 +0,4$ mm <sup>3)</sup>	All standards: -12,5 % + limited by weight <sup>1)</sup>  upon agreement ASTM A999: Minimum wall thickness There shall be no variation under the specified T
	$1 1/2 - 4"$ (over 48,3–114,3 mm, incl.) $-1/32$ (0.031) $+1/32$ (0.031) $-0,8 +0,8$ mm	
	$4 - 8$ (over 114,3–219,1 mm, incl.) $-1/32$ (0.031) $+1/16$ (0.062) $-0,8 +1,6$ mm	

1) According ASTM A 530 is plus tolerance of T (latest edition):  
 NPS 1/8 – 2 1/2", all t/D ratios +20%  
 NPS 3 – 18", up to t/D 5 % +22,5 %  
 NPS 3 – 18", t/D over 5 % +15 %

2) Ovality for thin-wall pipes (T ≤ 3% D) under 1,5% of specified D  
 3) ASTM A335 dimension range 1/8 - 1 1/2 tolerances - 1/64 (0,4 mm)

**Dimensions and weight of hot rolled seamless tubes according to standard**

**Table 9**

A/SA-192; A/SA-210; A/SA556 in connection with A/SA-450 - min T, A/SA-209; A/SA-213; A/SA-334 in connection with A/SA-1016 - min T (upon agreement A/SA-335 in connection with A/SA-999 - min T)

BWG - Birmingham Wire Gauge

weights are valid for average wall thickness

Wall thickness in BWG			Outside diameter																
Gauge	inch	mm	inch	1 1/4	1 1/2	1 3/4	2	2 1/8	2 1/4	2 1/2	3	3 1/4	3 1/2	4	4 1/4	4 1/2	5	5 1/2	
			mm	31,75	38,10	44,45	50,80	54,00	57,00	63,50	76,20	82,50	88,90	101,60	107,95	114,30	127,00	139,70	
13		2,41	kg/m	2,06	2,51	2,97	3,42	3,65	3,86	4,33	5,23								
	0,095		lbs/ft	1,38	1,69	1,99	2,30	2,45	2,60	2,91	3,51								
12		2,77	kg/m	2,29	2,80	3,31	3,82	4,07	4,31	4,84	5,86	6,36	6,87						
	0,109		lbs/ft	1,53	1,88	2,22	2,56	2,73	2,90	3,24	3,93	4,27	4,61						
11		3,05	kg/m	2,49	3,05	3,61	4,17	4,46	4,72	5,30	6,42	6,97	7,54	8,66	9,22	9,79			
	0,120		lbs/ft	1,67	2,05	2,42	2,80	2,99	3,18	3,55	4,31	4,68	5,06	5,81	6,19	6,57			
10		3,40	kg/m	2,73	3,36	3,99	4,61	4,93	5,22	5,86	7,11	7,73	8,37	9,62	10,24	10,87	12,12		
	0,134		lbs/ft	1,84	2,26	2,68	3,10	3,31	3,52	3,94	4,78	5,20	5,62	6,46	6,88	7,30	8,14		
9		3,76	kg/m	2,98	3,67	4,36	5,05	5,40	5,73	6,44	7,82	8,51	9,20	10,59	11,28	11,97	13,36		
	0,148		lbs/ft	2,00	2,46	2,93	3,39	3,62	3,86	4,32	5,25	5,71	6,18	7,11	7,57	8,04	8,96		
8		4,19	kg/m	3,23	4,00	4,76	5,53	5,91	6,27	7,06	8,59	9,34	10,11	11,64	12,41	13,17	14,70		
	0,165		lbs/ft	2,17	2,69	3,20	3,71	3,97	4,23	4,74	5,77	6,28	6,79	7,82	8,33	8,84	9,87		
7		4,57	kg/m	3,47	4,30	5,14	5,97	6,39	6,79	7,64	9,31	10,13	10,97	12,64	13,47	14,31	15,98		
	0,180		lbs/ft	2,33	2,89	3,45	4,01	4,29	4,57	5,13	6,25	6,81	7,37	8,49	9,05	9,61	10,73		
6		5,16	kg/m	3,75	4,67	5,59	6,52	6,98	7,42	8,36	10,20	11,11	12,04	13,89	14,81	15,73	17,57		
	0,203		lbs/ft	2,52	3,14	3,75	4,37	4,68	4,99	5,61	6,84	7,46	8,08	9,32	9,93	10,55	11,79		
5		5,59	kg/m	3,99	4,99	5,98	6,98	7,49	7,96	8,98	10,97	11,96	12,97	14,97	15,96	16,96	18,96	20,95	
	0,220		lbs/ft	2,68	3,35	4,02	4,69	5,02	5,36	6,03	7,36	8,03	8,70	10,04	10,71	11,38	12,72	14,06	
4		6,05	kg/m	4,23	5,31	6,39	7,47	8,01	8,52	9,63	11,79	12,86	13,95	16,11	17,19	18,27	20,43	22,59	
	0,238		lbs/ft	2,84	3,56	4,29	5,01	5,37	5,73	6,46	7,91	8,63	9,36	10,81	11,53	12,26	13,70	15,15	
3		6,58	kg/m		5,66	6,84	8,01	8,60	9,16	10,36	12,71	13,87	15,06	17,41	18,58	19,76	22,11	24,46	
	0,259		lbs/ft		3,80	4,59	5,38	5,77	6,16	6,95	8,53	9,32	10,11	11,68	12,47	13,26	14,84	16,41	
2		7,21	kg/m		7,34	8,63	9,28	9,89	11,21	13,78	15,06	16,35	18,93	20,22	21,50	24,08	26,65		
	0,284		lbs/ft		4,93	5,80	6,23	6,66	7,53	9,26	10,12	10,98	12,71	13,58	14,44	16,17	17,90		
1		7,62	kg/m		7,66	9,02	9,71	10,35	11,74	14,46	15,81	17,18	19,90	21,27	22,63	25,35	28,07		
	0,300		lbs/ft		5,14	6,06	6,51	6,97	7,88	9,71	10,62	11,54	13,36	14,28	15,19	17,02	18,84		
0		8,64	kg/m		8,40	9,95	10,72	11,45	13,03	16,12	17,65	19,20	22,29	23,83	25,37	28,46	31,54		
	0,340		lbs/ft		5,64	6,68	7,19	7,71	8,75	10,82	11,85	12,89	14,96	15,99	17,03	19,10	21,17		
2/0		9,65	kg/m						12,48	14,25	17,69	19,40	21,14	24,58	26,31	28,03	31,48	34,92	
	0,380		lbs/ft						8,41	9,56	11,88	13,03	14,19	16,50	17,66	18,82	21,13	23,45	
3/0		10,80	kg/m						13,56	15,54	19,39	21,30	23,25	27,10	29,03	30,95	34,81	38,66	
	0,425		lbs/ft						9,14	10,43	13,02	14,31	15,61	18,19	19,49	20,78	23,37	25,96	
4/0		11,53	kg/m								20,44	22,49	24,56	28,68	30,74	32,80	36,91	41,03	
	0,454		lbs/ft								13,72	15,11	16,49	19,25	20,63	22,02	24,78	27,54	
5/0		12,70	kg/m								22,04	24,29	26,57	31,11	33,37	35,64	40,18	44,71	
	0,500		lbs/ft								14,79	16,32	17,84	20,88	22,41	23,93	26,97	30,02	

SWG - Standard Wire Gauge

weights are valid for average wall thickness

Wall thickness in SWG			Outside diameter																
Gauge	inch	mm	inch	1 1/4	1 1/2	1 3/4	2	2 1/8	2 1/4	2 1/2	3	3 1/4	3 1/2	4	4 1/4	4 1/2	5	5 1/2	
			mm	31,75	38,10	44,45	50,80	54,00	57,00	63,50	76,20	82,50	88,90	101,60	107,95	114,30	127,00	139,70	
13		2,34	kg/m	2,00	2,44	2,88	3,32	3,54											
	0,088		lbs/ft	1,29	1,57	1,85	2,14	2,28											
12		2,64	kg/m	2,19	2,68	3,16	3,65	3,89	4,12	4,62	5,59	6,07							
	0,104		lbs/ft	1,47	1,80	2,12	2,45	2,61	2,78	3,10	3,76	4,08							
11		2,95	kg/m	2,42	2,96	3,50	4,05	4,32	4,58	5,13	6,22	6,76	7,30						
	0,116		lbs/ft	1,62	1,99	2,35	2,71	2,90	3,08	3,44	4,17	4,53	4,90						
10		3,25	kg/m	2,63	3,23	3,83	4,42	4,73	5,01	5,62	6,82	7,41	8,01	9,21	9,81	10,40			
	0,128		lbs/ft	1,77	2,17	2,57	2,97	3,17	3,37	3,77	4,58	4,98	5,38	6,18	6,59	6,99			
9		3,66	kg/m	2,91	3,58	4,26	4,93	5,27	5,59	6,28	7,63	8,29	8,97	10,32	10,99	11,67	13,01		
	0,144		lbs/ft	1,95	2,41	2,86	3,31	3,53	3,76	4,21	5,12	5,57	6,02	6,92	7,38	7,83	8,73		
8		4,06	kg/m	3,15	3,89	4,63	5,37	5,75	6,10	6,86	8,34	9,07	9,82	11,30	12,04	12,78	14,26		
	0,160		lbs/ft	2,12	2,62	3,11	3,61	3,86	4,11	4,61	5,60	6,10	6,60	7,59	8,09	8,59	9,58		
7		4,47	kg/m	3,41	4,22	5,04	5,86	6,27	6,65	7,49	9,12	9,93	10,75	12,38	13,19	14,01	15,64		
	0,176		lbs/ft	2,29	2,84	3,38	3,93	4,20	4,48	5,03	6,12	6,67	7,22	8,31	8,86	9,41	10,50		
6		4,88	kg/m	3,59	4,46	5,34	6,21	6,65	7,06	7,95	9,69	10,56	11,43	13,18	14,05	14,92	16,66		
	0,192		lbs/ft	2,41	3,00	3,58	4,16	4,46	4,75	5,33	6,50	7,09	7,67	8,84	9,42	10,01	11,18		
5		5,39	kg/m	3,88	4,84	5,80	6,77	7,25	7,71	8,69	10,62	11,57	12,54	14,46	15,43	16,39	18,31		
	0,212		lbs/ft	2,60	3,25	3,89	4,54	4,86	5,18	5,83	7,12	7,77	8,41	9,70	10,35	10,99	12,28		
4		5,89	kg/m	4,15	5,20	6,25	7,30	7,83	8,33	9,40	11,51	12,55	13,61	15,71	16,76	17,82	19,92	22,02	
	0,232		lbs/ft	2,78	3,49	4,20	4,90	5,26	5,61	6,32	7,73	8,43	9,14	10,55	11,26	11,97	13,38	14,79	
3		6,40	kg/m		5,54	6,69	7,83	8,40	8,94	10,11	12,40	13,53	14,68	16,97	18,11	19,25	21,54	23,82	
	0,252		lbs/ft		3,72	4,49	5,26	5,64	6,02	6,79	8,32	9,09	9,86	11,39	12,16	12,93	14,46	16,00	
2		7,01	kg/m		5,93	7,19	8,44	9,07	9,66	10,94	13,44	14,68	15,95	18,45	19,70	20,95	23,45	25,96	
	0,276		lbs/ft		3,98	4,82	5,66	6,08	6,50	7,34	9,02	9,87	10,71	12,39	13,23	14,07	15,75	17,43	
1		7,62	kg/m		7,66	9,02	9,71	10,35	11,74	14,46	15,81	17,18	19,90	21,27	22,63	25,35	28,07		
	0,300		lbs/ft		5,14	6,06	6,51	6,97	7,88	9,71	10,62	11,54	13,36	14,28	15,19	17,02	18,84		
0		8,24	kg/m		8,12	9,59	10,33	11,02	12,53	15,47	16,93	18,41	21,35	22,82	24,29	27,23	30,17		
	0,324		lbs/ft		5,45	6,43	6,93	7,42	8,41	10,38	11,36	12,35	14,32	15,31	16,30	18,27	20,24		



Wall thickness in SWG			Outside diameter															
Gauge	inch	mm	inch	1 1/4	1 1/2	1 3/4	2	2 1/8	2 1/4	2 1/2	3	3 1/4	3 1/2	4	4 1/4	4 1/2	5	5 1/2
			mm	31,75	38,10	44,45	50,80	54,00	57,00	63,50	76,20	82,50	88,90	101,60	107,95	114,30	127,00	139,70
2/0	0,348	8,84	kg/m			8,54	10,12	10,92	11,66	13,28	16,43	18,00	19,59	22,74	24,32	25,90	29,06	32,21
			lbs/ft			5,73	6,79	7,32	7,85	8,91	11,03	12,09	13,15	15,27	16,33	17,39	19,51	21,63
3/0	0,372	9,45	kg/m						12,28	14,00	17,37	19,05	20,75	24,12	25,81	27,49	30,86	34,24
			lbs/ft						8,27	9,40	11,67	12,80	13,93	16,20	17,33	18,46	20,73	22,99
4/0	0,400	10,16	kg/m						12,97	14,83	18,46	20,26	22,08	25,71	27,53	29,34	32,97	36,60
			lbs/ft						8,74	9,96	12,39	13,61	14,83	17,26	18,48	19,70	22,13	24,57
5/0	0,432	10,97	kg/m						13,73	15,73	19,65	21,59	23,57	27,48	29,44	31,40	35,32	39,24
			lbs/ft						9,25	10,56	13,19	14,51	15,82	18,45	19,77	21,08	23,71	26,34
6/0	0,464	11,78	kg/m								20,79	22,88	24,99	29,20	31,30	33,41	37,61	41,82
			lbs/ft								13,96	15,37	16,79	19,61	21,02	22,44	25,26	28,09
7/0	0,500	12,70	kg/m								22,04	24,29	26,57	31,11	33,37	35,64	40,18	44,71
			lbs/ft								14,79	16,32	17,84	20,88	22,41	23,93	26,97	30,02

Tube tolerances – see page 47 - table 10 and 11. For tubes are valid minimal wall thickness - so the tolerances of T are only plus.

The deliveries of hot finished tubes to these tolerances only upon agreement.

Hot finished tubes are usually delivered with average wall thickness (two sided tolerances of T).

Method of manufacture and delivery conditions – hot finished or cold drawn – depend on tube dimension or upon agreement (See table 5, page 40-41)

**Allowed outside diameter tolerances according to ASTM A450/A450M, ASTM A1016/A1016M (ASME SA) Table 10**

Outside diameter			
Hot finished	to 4" (101,6 mm)	-1/32 (0,8 mm)	+1/64 (0,4 mm)
	over 4"-7 1/2" (101,6-190,5 mm)	-3/64 (1,2 mm)	+1/64 (0,4 mm)
Cold finished	to 1" (25,4 mm)	-0.004 (0,1 mm)	+0.004 (0,1 mm)
	over 1"-1 1/2" (25,4-38,1 mm)	-0.006 (0,15 mm)	+0.006 (0,15 mm)
	over 1 1/2"-2" (38,1-50,8 mm)	-0.008 (0,2 mm)	+0.008 (0,2 mm)
	over 2"-2 1/2" (50,8-63,5 mm)	-0.010 (0,25 mm)	+0.010 (0,25 mm)
	over 2 1/2"-3" (63,5-76,2 mm)	-0.012 (0,3 mm)	+0.012 (0,3 mm)
	over 3"-4" (76,2-101,6 mm)	-0.015 (0,38 mm)	+0.015 (0,38 mm)
	over 4"-7 1/2" (101,6-190,5 mm)	-0.015 (0,38 mm)	+0.025 (0,64 mm)

Ovality for thin-wall tubes [T≤0,020in (0,5mm) / T≤2% D up to D=2in (50,8mm) / T≤3% D for D over 2in]:

Tubes with D≤1in (25,4mm) = 0,020in (0,5mm), tubes with D>1in = up to 2% of D (difference of maximum values)

**Allowed wall thickness tolerances according to ASTM A450/A450M, ASTM A1016/A1016M (ASME SA) Table 11**

Wall thickness				
Hot finished	to 0,095" (2,4 mm)	over 0,095" - 0,15"	0,15" - 0,18" (3,8 - 4,6 mm)	over 0,18" (4,6 mm)
	0 +40 %	(2,4 - 3,8 mm) 0 +35 %	0 +33 %	0 +28 %
Cold finished	With outside diameter			
	to 1 1/2" (38,1 mm)	0 +20%	over 1 1/2" (38,1 mm)	0 +22%

For tubes with D≥2in and T≥0,220in are permitted divergences from calculated average T ±10%.

**Dimensions and weight of steel tubes according to JIS standards (Tubes) Table 12**

Outside diameter [mm]	Wall thickness [mm]																
	1,2	1,6	2,0	2,3	2,6	2,9	3,2	3,5	4,0	4,5	5,0	5,5	6,0	6,5	7,0	8,0	9,5
	Tube weight [kg/m]																
15,9	0,435	0,564	0,686	0,771	0,853	0,930											
19,0		0,687	0,838	0,947	1,05	1,15											
21,7			0,972	1,10	1,22	1,34	1,46										
25,4			1,15	1,31	1,46	1,61	1,75	1,89									
27,2			1,24	1,41	1,58	1,74	1,89	2,05	2,29								
31,8				1,67	1,87	2,07	2,26	2,44	2,74	3,03							
34,0					2,01	2,22	2,43	2,63	2,96	3,27	3,58						
38,1					2,28	2,52	2,75	2,99	3,36	3,73	4,08	4,42					
42,7					2,57	2,85	3,12	3,38	3,82	4,24	4,65	5,05	5,43				
45,0					2,72	3,01	3,30	3,58	4,04	4,49	4,93	5,36	5,77	6,17			
48,6					2,95	3,27	3,58	3,89	4,40	4,89	5,38	5,85	6,30	6,75	7,18		
50,8					3,09	3,43	3,76	4,08	4,62	5,14	5,65	6,14	6,63	7,10	7,56	8,44	
54,0					3,30	3,65	4,01	4,36	4,93	5,49	6,04	6,58	7,10	7,61	8,11	9,07	
57,1						3,88	4,25	4,63	5,24	5,84	6,42	7,00	7,56	8,11	8,65	9,69	
60,3						4,10	4,51	4,90	5,55	6,19	6,82	7,43	8,03	8,62	9,20	10,3	
63,5						4,33	4,76	5,18	5,87	6,55	7,21	7,87	8,51	9,14	9,75	10,9	12,7
65,0						4,44	4,88	5,31	6,02	6,71	7,40	8,07	8,73	9,38	10,00	11,2	13,0
70,0						4,80	5,27	5,74	6,51	7,27	8,01	8,75	9,47	10,20	10,90	12,2	14,2
76,2							5,76	6,27	7,12	7,96	8,78	9,59	10,40	11,20	11,90	13,5	15,6
82,6							6,27	6,83	7,75	8,67	9,57	10,50	11,30	12,20	13,10	14,7	17,1
88,9							6,76	7,37	8,37	9,37	10,30	11,30	12,30	13,20	14,10	16,0	18,6
101,6								8,47	9,63	10,80	11,90	13,00	14,10	15,20	16,30	18,5	21,6
114,3									10,90	12,20	13,50	14,80	16,00	17,30	18,50	21,0	24,6

## Steel heat exchangers tubes

Standards	Dimensional standards	Dimensional range	Dimensions				
			Tolerance D	Tolerance T	Lengths	Straightness	Tube ends
<b>SEAMLESS TUBES</b>							
EN	10216-2	Table 5/Page 40	* Heat exchangers tubes are supplied as cold drawn in preference (Table 16 at page 51)				
DIN	28180 (2391-1)	Table 16/Page 51	Tolerance class TK1: D = 16–30 mm ±0,08 mm D > 38 mm ±0,15 mm  Tolerance class TK3: D = 16–38 mm ±0,50 mm	T ≤ 2 mm ±0,2 mm T > 2 mm ±10 %  T ≤ 2 mm ±0,2 mm T > 2 mm -10 % +15 %	Exact lengths: L ≤ 5 m 0 +5 mm L 5–10 m 0 +10 mm L > 10 m upon agreement (seamless max. 18,3 m)	• visually straight • upon agreement	• square cut ends • free from excessive burrs
BS	3606	Table 23/Page 68	D ≤ 25 mm ±0,10 mm D = 25–38 mm ±0,15 mm D 38–50 mm ±0,20 mm  Smaller tolerances are possible after agreement	• ±10 % • upon agreement: D ≤ 38 mm 0 +20 % D > 38 mm 0 +22 %	Exact lengths: L ≤ 6 m 0 +3 mm L > 6 m +1,5 mm/m, max +12,5 mm	visually straight	
NF A	49-215	Table 23/Page 68	See page 36				
UNI	ISO 1129	Table 23/Page 68	See page 28				
STN ČSN	42 6710 42 6711	Table 23/Page 68	See page 28				
GOST	8734 (8732)	Table 23/Page 68	Cold finished: D = 5–10 mm ±0,15 mm D = 10–30 mm ±0,30 mm D = 30–50 mm ±0,40 mm D > 50 mm ±0,8 %	T ≤ 1 mm ±0,12 mm T = 1–5 mm ±10 %	• random • exact 0 +10 mm	D = 5–8 mm 3 mm/m D = 8–10 mm 2 mm/m D > 10 m 1,5 mm/m	• square cut ends • free from excessive burrs • non-uprightness <sup>2</sup> • beveled for T > 5 mm
	1060		D ≤ 29 mm ±0,2 mm D = 29–51 mm ±0,30 mm D > 51 mm -0,8% + 0,6%	• Class 1 -10 % +8 % • Class 2 ±8 %			
ASTM ASME	A179 SA-179	Table 14/Page 51	According to ASTM A450 See table10/page 47	See table11/page 47	• upon agreement • max 20,0 m		• square cut ends • free from excessive burrs
JIS	G3461	Table 12/Page 47	See page 30	See page 30			• square cut ends • free from excessive burrs
	G3462						

1. Delivery of tubes according to other standards for seamless tubes
2. See also standards for pressure equipment (pages 23–25, 32–33, 35, 39)
3. See also standards for low temperature tubes acc. to ASTM and ASME (page 39)
4. For low temperatures tubes according to STN, ČSN 42 0165 (page 48)
5. ISO 6759 Seamless steel tubes for heat exchangers
6. Tubular exchanger manufacturers association (TEMA) issues standards for exchanger construction, that refer to tube standards

### List of dimensional standards and technical delivery conditions standards

EN 10216-2	Seamless steel tubes for pressure purposes. TDC. Part 2: Non-alloy and alloy steel tubes with specified elevated temperature properties.
DIN 1629	Seamless circular tubes of non-alloy steel with special quality requirements. TDC.
DIN 2391-1	Seamless precision steel tubes. Part 1: Dimensions.
DIN 17175	Seamless steel tubes for elevated temperatures. TDC.
DIN 28180	Seamless steel tubes for tubular heat exchangers. Dimensions, tolerances, materials.
BS 3606	Steel tubes for heat exchangers.

TDC standards	Name	Steel grade		Testing and certificates		Other TDC			
		Condition	Surface	Testing	Certificate	Marking	Surface protection	Packing	
10216-2	P235GH 16Mo3	See boiler tubes page 27							
1629 17175 17173 *	St37.0 St35.8 15Mo3 TTSt35N	Cold finished • normalized(NBK)			See page 23 See page 27  See page 37 * In new issue of DIN 28180 the former steel grades were replaced by steel grades in acc. to EN 10216-2 (P235GH, 16Mo3, 13CrMo4-4) and EN 10216-4 (P215NL). (Testing category TC1, class TK1 or TK3.)				
3606	320 440 243 620 622	N N N, N + T N N + T Cold finished • condition upon steel or agreement		• product analysis • dimensions • visual • tensile test • flattening • drift expanding • hydrostatic test • NDT - ultrasonic - eddy current	• test certificate • test result				
49-215	TU37C TU42C TU48C TU15D3 TU13CD4-04	N N N N N + T	See page 29 and 37						
5462	16Mo5		See page 29						
42 0251	12 021 12 022 12 025 15 020  15 121 15 128 15 313	Cold finished • normalized number .1 behind steel  Cold finished • normalized and temper. number .5 behind steel	See page 29						
550	1050: 10 20 4543: 10G2	Cold finished • normalized		• product analysis • dimensions • tensile test • impact test • flattening • drift expanding • hardness	10692				
1060	1050: 10								
A179 (A450) SA-179 A161 A 199 A335	A179  Grade C Grade T-1 Grade T4 Grade T11 Grade T12	Cold finished • normalized		• product analysis • hardness • flattening • drift expanding • flanging • NDT according to E309 (HF upon agreement)		• each tube marked according to A 450 and • name and order of the purchaser		Upon agreement	
G3461  G3462	STB340 STB410 STB510  STBA12	Cold finished • normalized	See page31						

- NFA 49-215 Seamless tubes for ferritic non alloy and alloy steel heat exchangers.
- STN 42 0251 ČSN 42 0251 Seamless steel tubes with guaranteed properties at elevated temperatures. TDC.
- STN 42 6710 ČSN 42 6710 Cold drawn seamless tubes with normal tolerances from steel class 11–16. Dimensions.
- STN 42 6711 ČSN 42 6711 Precision seamless steel tubes. Dimensions.
- GOST 550 Seamless steel tubes for petroleum processing and petrochemical industry.
- GOST 8734 Seamless steel tubes cold deformed.
- ANSI/ASME B 36.10M Welded and seamless wrought steel pipe. Dimensions.
- ASTM A179 Seamless cold drawn low-carbon steel heat exchanger and condenser tubes. TDC.
- ASTM A199 Seamless cold drawn intermediate alloy steel heat exchanger and condenser tubes. TDC.
- ASTM A214 Electric resistance welded carbon steel heat exchanger and condenser tubes.
- ASTM A334 Seamless and welded carbon and alloy-steel tubes for low-temperature service. TDC.
- ASTM A450 General requirements for carbon, ferritic alloy and austenitic alloy steel tubes. TDC.
- JIS G 3461 Carbon steel boiler and heat exchanger tubes.
- JIS G 3462 Alloy steel boiler and heat exchanger tubes.

## Steels grades, chemical composition and mechanical properties

Standards	Steel	Chemical composition [%]										Mechanical properties					
		C	Si	Mn	Pmax	Smax	Cr	Ni	Mo	Cu	Other	Re min MPa	Re min ksi	Rm min MPa	Rm max MPa	A5 min ksi	A5 min %
<b>STN, ČSN</b>																	
	11 368	max.0,15	max.0,35	min.0,40	0,040	0,040	max.0,30	max.0,30			max.0,30		245	350	440	26	
	11 418	max.0,20	max.0,35	max.0,50	0,040	0,040	max.0,30	max.0,30			max.0,30		255	400	490	24	
	12 021	0,07–0,15	0,17–0,35	0,35–0,60	0,040	0,040	max.0,25	max.0,25			max.0,25		235	340	470	25	
	12 022	0,15–0,22	0,17–0,37	0,50–0,80	0,040	0,040	max.0,25	max.0,25			max.0,25		255	410	570	21	
	12 025	0,14–0,20	0,17–0,37	0,60–1,00	0,040	0,040	max.0,25	max.0,25			max.0,25	V 0,05–0,09	320	440	600	23	
	15 020	0,12–0,20	0,15–0,37	0,50–0,80	0,040	0,040				0,25–0,35		Al min.0,015	270	450	600	22	
	15 121	0,10–0,18	0,15–0,35	0,40–0,70	0,040	0,040	0,70–1,30			0,40–0,60			295	440	590	22	
	15 128	0,10–0,18	0,15–0,40	0,45–0,70	0,040	0,040	0,50–0,75			0,40–0,60		V 0,22–0,35	365	490	690	18	
<b>ASTM</b>																	
A 161	Grade C	0,10–0,20	max. 0,25	0,30–0,80	0,035	0,035							179	26	324	47	35
	Grade T-1	0,10–0,20	0,10–0,50	0,30–0,80	0,025	0,025				0,44–0,65			207	30	379	55	30
A 179		0,06–0,18		0,27–0,63	0,035	0,035									max.72 HRB		
A 199	Grade T4	0,05–0,15	0,50–1,00	0,30–0,60	0,025	0,025	2,15–2,85	max. 0,40		0,44–0,65		V 0,18–0,25 max. 0,04	170	25	415	60	30
	Grade T11	0,05 - 0,15	0,50 - 1,00	0,30 - 0,60	0,025	0,025	1,00 - 1,50			0,44 - 0,65			170	25	415	60	30
A 335	Grade P12	0,05–0,15	max.0,50	0,30–0,61	0,025	0,025	0,80–1,25			0,44–0,65			220	32	415	60	30
<b>DIN</b>																	
1629	St 37.0	max.0,17			0,040	0,040							235		350	480	25
17175	St 35.8	max.0,17	0,10–0,35	0,40–0,80	0,040	0,040							235		360	480	25
	15Mo3	0,12–0,20	0,10–0,35	0,40–0,80	0,035	0,035				0,25–0,35			270		450	600	22
<b>BS</b>																	
3606	320	max.0,16	–	0,30–0,70	0,050	0,050							195		–		21
	440	0,12–0,18	0,10–0,35	0,90–1,20	0,040	0,035							265		440		21
	243	0,12–0,20	0,10–0,35	0,40–0,80	0,040	0,040				0,25–0,35		Al max.0,12	250		450		22
	620	0,10–0,15	0,10–0,35	0,40–0,70	0,040	0,040	0,70–1,10			0,45–0,65		Al max.0,20	180		460		22
<b>UNI</b>																	
5462	16Mo5	0,12–0,20	0,15–0,35	0,50–0,80	0,035	0,035				0,45–0,65			290		450	550	22
<b>NF A</b>																	
49-215	TU 37c	max.0,18	0,05–0,27	0,30–0,80	0,045	0,045					max.0,25	Sn 0,03	220		360	450	
	TU 42c	max.0,22	0,07–0,40	0,40–1,05	0,045	0,045					max.0,25	Sn 0,03	235		410	510	
	TU 48c	max.0,24	0,09–0,40	0,60–1,30	0,045	0,045					max.0,25	Sn 0,03	275		470	570	
	TU 15D3	0,10–0,22	0,10–0,40	0,40–0,90	0,040	0,040	max.0,40	max.0,30	0,21–0,39		max.0,25	Sn 0,03	265		430	530	22
	TU 13CD4-04	0,08–0,20	0,05–0,40	0,30–0,80	0,035	0,035	0,65–1,15	max.0,30	0,61–0,69		max.0,25	Sn 0,03	290		440	590	22
<b>EN</b>																	
10216-2	P 235 GH	max.0,16	max.0,35	max.1,20	0,025	0,020	max.0,30	max.0,30	max.0,08	max.0,30		V max. 0,02 Ti max.0,04 Al min. 0,020	235		360	500	25
	16Mo3	0,12 - 0,20	0,15 - 0,35	0,40 - 0,80	0,030	0,025			0,25 - 0,35			Al max.0,040	280		450	600	22
<b>GOST</b>																	
1050	10	0,07–0,14	0,17–0,37	0,35–0,65			max.0,15						205		330		31
	20	0,17–0,24	0,17–0,37	0,35–0,65			max.0,25						245		410		25
4543	10G2	0,07–0,15	0,17–0,37	1,20–1,60									245		420		22
<b>JIS</b>																	
G3461	STB 340	max.0,18	max.0,35	0,30–0,60	0,035	0,035							175		340		35
	STB 410	max.0,32	max.0,35	0,30–0,80	0,035	0,035							255		410		25
	STB 510	max.0,25	max.0,35	1,00–1,50	0,035	0,035							295		510		25
G3462	STBA 12	0,10–0,20	0,10–0,50	0,30–0,80	0,035	0,035				0,45–0,65			205		380		30
	STBA 22	max.0,15	max.0,50	0,30–0,60	0,035	0,035	0,80–1,25			0,45–0,65			205		410		30

Other steel grades for low temperature application see page 39.

## Dimensions and weight of steel pipes according to JIS standards (Pipes)

Table13

Nominal diameter [mm]		Outside diameter [mm]	Nominal wall thickness					
A	B		Schedule 40		Schedule 80		Schedule 160	
			Thickness [mm]	Weight [kg/m]	Thickness [mm]	Weight [kg/m]	Thickness [mm]	Weight [kg/m]
6	1/8	10,5	1,70	0,369	2,40	0,479		
8	1/4	13,8	2,20	0,629	3,00	0,799		
10	3/8	17,3	2,30	0,851	3,20	1,11		
15	1/2	21,7	2,80	1,31	3,70	1,64		
20	3/4	27,2	2,90	1,74	3,90	2,24		
25	1	34,0	3,40	2,57	4,50	3,27		
32	1 1/4	42,7	3,60	3,47	4,90	4,57	6,40	5,73
40	1 1/2	48,6	3,70	4,10	5,10	5,47	7,10	7,27
50	2	60,5	3,90	5,44	5,50	7,46	8,70	11,10
65	2 1/2	76,3	5,20	9,12	7,00	12,00	9,50	15,60
80	3	89,1	5,50	11,30	7,60	15,30	11,10	21,40
90	3 1/2	101,6	5,70	13,50	8,10	18,70		
100	4	114,3	6,00	16,00	8,60	22,40	13,50	33,60

Note: The tube and pipe are hot formed or cold formed (according technical possibilities or agreement).



**Cold Drawn steel tubes for heat exchangers with a minimum wall thickness (sizes in inch)**

**Table 14**

Outside diameter		Minimum wall thickness													
		BWG (inch)	20 (.035)	18 (.049)	16 (.065)	14 (.083)	13 (.095)	12 (.109)	11 (.120)	10 (.134)	9 (.148)	8 (.165)	7 (.180)	6 (.203)	5 (.220)
[mm]	[inch]	[mm]	0,89	1,24	1,65	2,11	2,41	2,77	3,05	3,40	3,76	4,19	4,57	5,16	5,59
12,70	1/2	lb/ft	0,190	0,256	0,327	0,399	0,441	0,487	0,519	0,555	0,586				
	.500	kg/m	0,283	0,351	0,487	0,594	0,657	0,725	0,773	0,826	0,873				
15,88	5/8	lb/ft	0,242	0,328	0,423	0,521	0,581	0,647	0,696	0,752	0,804				
	.625	kg/m	0,360	0,488	0,630	0,776	0,865	0,964	1,036	1,120	1,198				
19,05	3/4	lb/ft	0,290	0,400	0,518	0,643	0,720	0,807	0,872	0,948	1,021				
	.750	kg/m	0,431	0,595	0,771	0,957	1,072	1,202	1,299	1,412	1,521				
22,23	7/8	lb/ft		0,472	0,614	0,767	0,864	0,973	1,056	1,158					
	.875	kg/m		0,702	0,913	1,141	1,285	1,448	1,571	1,722					
25,40	1	lb/ft		0,543	0,709	0,887	0,998	1,128	1,225	1,342	1,456	1,587	1,696		
	1.000	kg/m		0,808	1,056	1,321	1,487	1,680	1,824	1,998	2,169	2,363	2,526		
31,75	1 1/4	lb/ft		0,686	0,900	1,131	1,277	1,448	1,577	1,734	1,891	2,071	2,225	2,451	2,607
	1.250	kg/m		1,022	1,340	1,684	1,902	2,157	2,349	2,583	2,816	3,085	3,313	3,650	3,882
38,10	1 1/2	lb/ft		0,830	1,090	1,375	1,556	1,769	1,930	2,128	2,326	2,556	2,753	3,047	3,253
	1.500	kg/m		1,236	1,624	2,048	2,317	2,634	2,875	3,169	3,464	3,807	4,100	4,538	4,845
50,80	2	lb/ft			1,472	1,863	2,114	2,409	2,636	2,914	3,196	3,525	3,810	4,241	4,547
	2.000	kg/m			2,192	2,775	3,148	3,588	3,925	4,340	4,759	5,250	5,674	6,316	6,771
63,50	2 1/2	lb/ft			1,854	2,351	2,671	3,050	3,341	3,701	4,066	4,494	4,867	5,435	5,839
	2.500	kg/m			2,761	3,502	3,978	4,542	4,976	5,512	6,055	6,693	7,249	8,094	8,696
76,20	3	lb/ft				2,840	3,228	3,691	4,047	4,487	4,935	5,464	5,924	6,628	7,132
	3.000	kg/m				4,229	4,808	5,497	6,027	6,683	7,350	8,137	8,823	9,871	10,622

**Cold Drawn steel tubes for heat exchangers with a medium wall thickness (sizes in inch)**

**Table 15**

Outside diameter		Medium wall thickness													
		BWG (inch)	20 (.035)	18 (.049)	16 (.065)	14 (.083)	13 (.095)	12 (.109)	11 (.120)	10 (.134)	9 (.148)	8 (.165)	7 (.180)	6 (.203)	5 (.220)
[mm]	[inch]	[mm]	0,89	1,24	1,65	2,11	2,41	2,77	3,05	3,40	3,76	4,19	4,57	5,16	5,59
12,70	1/2	lb/ft	0,173	0,236	0,302	0,369	0,410	0,445	0,487	0,523	0,557				
	.500	kg/m	0,259	0,351	0,450	0,551	0,612	0,678	0,726	0,780	0,829				
15,88	5/8	lb/ft	0,220	0,301	0,388	0,480	0,537	0,600	0,647	0,703	0,754				
	.625	kg/m	0,328	0,447	0,579	0,716	0,801	0,897	0,965	1,046	1,124				
19,05	3/4	lb/ft	0,267	0,366	0,475	0,591	0,664	0,745	0,807	0,881	0,952				
	.750	kg/m	0,398	0,547	0,708	0,881	0,989	1,110	1,203	1,312	1,418				
22,23	7/8	lb/ft		0,432	0,562	0,702	0,791	0,891	0,967	1,060					
	.875	kg/m		0,643	0,836	1,045	1,177	1,326	1,439	1,577					
25,40	1	lb/ft		0,497	0,649	0,812	0,918	1,037	1,128	1,239	1,346	1,471	1,575		
	1.000	kg/m		0,740	0,966	1,212	1,366	1,550	1,681	1,845	2,006	2,192	2,347		
31,75	1 1/4	lb/ft		0,628	0,822	1,034	1,172	1,328	1,448	1,597	1,741	1,912	2,056	2,272	2,417
	1.250	kg/m		0,933	1,225	1,542	1,744	1,980	2,159	2,377	2,595	2,848	3,063	3,383	3,606
38,10	1 1/2	lb/ft		0,759	0,996	1,256	1,426	1,619	1,769	1,955	2,137	2,353	2,537	2,814	3,009
	1.500	kg/m		1,127	1,483	1,870	2,121	2,413	2,636	2,909	3,184	3,504	3,779	4,191	4,481
50,80	2	lb/ft			1,343	1,699	1,933	2,201	2,409	2,670	2,929	3,246	3,499	3,896	4,185
	2.000	kg/m			2,000	2,533	2,876	3,281	3,591	3,974	4,362	4,816	5,210	5,807	6,232
63,50	2 1/2	lb/ft			1,690	2,143	2,440	2,783	3,050	3,385	3,717	4,126	4,460	4,980	5,360
	2.500	kg/m			2,517	3,194	3,631	4,148	4,547	5,039	5,539	6,128	6,641	7,424	7,983
76,20	3	lb/ft				2,586	2,947	3,365	3,691	4,102	4,508	5,006	5,421	6,064	6,536
	3.000	kg/m				3,855	4,385	5,016	5,502	6,104	6,717	7,440	8,072	9,040	9,734

Note: Other D and T (according SWG) – see table 55 page 117, table 9 page 46, table 23 page 68, table 28 page 71 a table 30 page 72.

**Cold drawn steel heat exchanger tubes (sizes in mm)**

**Table 16**

Outside diameter [mm]	Wall thickness [mm]							
	1,2	1,6	2	2,6	3,2	4	4,5	5
	Tube weight [kg/m]							
16	0,438	0,568	0,691					
20		0,726	0,888	1,12				
25		0,923	1,13	1,44	1,72			
30		1,12	1,38	1,76	2,11	2,56		
38			1,78	2,27	2,75	3,35		
51 (50)			2,42	3,1	3,77	4,64	5,16	5,67

## Tubes with internal ribs

Today, there is still prevailing use of tubes with smooth surface for the purposes of construction as well as reconstruction of energy type facilities even despite that fact that tubes with surface structure (tubes with interior ribbing) positively influence performance of energy type facilities.

Tubes with interior ribbing are intended for high-performance steam generators, for high-pressure boilers and are also used in the area of burners and other equipments.

Interior ribs cause separation of steam and liquid as a result of centrifugal power, whereby the fluid phase (water) is forced to the tube wall, where it is stored longer as a water film. Using this method prevents occurrence of boiling on the interior tube wall which prevents exchange of heat and may also be the cause of occurrence of critical zones of commencing distortion of steel tube. Admissible share of water steam while retaining the heat flow and using ribbed tubes thus increases in the interval of 20 – 40 %, when using smooth surface tubes to 70 – 90 %.

That phenomenon results in increasing the contact surface area between the liquid part and tube wall, which brings about the following benefits:

- Improves the level of heat transfer even with a higher share of steam,
- A very good level of heat transfer is retained also at lower medium flow,
- Temperature of tube walls is reduced and so is the risk of distortion of tubes,
- It also prepares the room for improvement of heat transfer by a suitable optimization of ribs geometry.

On the other hand, for the purpose of reconstruction of older energy type facilities, it is possible to apply ribbed tubes to increase the output of the facility while retaining facility's dimensions. Last but not least, ribs have an interesting attenuating effect, which prevents from sedimentation of solid particles present in the medium, which contributes to limitation of the occurrence of corrosion processes and it has a favorable impact on the increase of tube lifespan. That is a clear representation of general economic and ecological contribution of such tubes

The heat transmission degree can be optimized by a suitable choice of rib geometry, depending on existing operating conditions of the equipment (boiler or heat exchanger). Each tube is tested by ultrasound or eddy current in order to ensure required quality features.

Tubes are supplied in quality grades in accordance with EN 10216, JIS G3461 – 3462, ASTM, ASME A/SA 192, 209 210 A 213 and other corresponding standards. Below you can find a breakdown of size assortment of tubes with interior ribbing supplied by Železiarne Podbrezová a.s. as it is shown in table 17 and 18.:

Parameters of tubes with internal ribs

Table 17

Symbol	Parameter	Range	
		[mm]	[inch]
D	Outside diameter	18–72	.750–3.000
T	Tube wall thickness	1–6,5	.047–.250
	Number of ribs	6–8	
h	Rib height	0,3–1,0	.016–.047
f	Rib width at the top (cross section)	3–8	.125–.313
β	Rib side angle	30°	
r	Rib radius	0,1–0,15	.004–.006
a	Rib pitch angle	25°–35°	
	Rib pitch length (360°)	depending on D	
	Distance of rib centers in the longitudinal direction	upon agreement	
s	Rib width at the top (longitudinal section)	upon agreement	
	Width of the distance between ribs at the top (longitudinal section)	upon agreement	
	Inside tube circumference	upon agreement	
	Transversal tube diameter	upon agreement	
	Tube weight	kg/m	lb/ft
	Tube length	upon agreement	

Dimensions of tubes with internal ribs

Table 18

	Wall thickness [mm]													
	0,5	1	1,5	2	2,5	3	3,5	4	4,5	5	5,5	6	6,5	
	Maximum rib height [mm]													
18														
20														
25		0,5 mm												
30														
35														
40														
45					0,7 mm									
50														
55									1 mm					
60														
65														
70														
72														

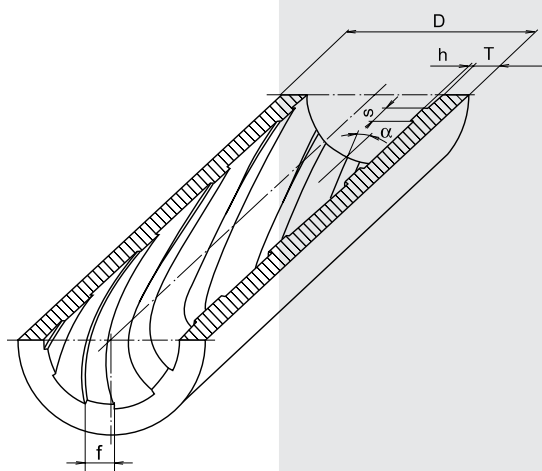

## Seamless steel tubes for welding and threading

Standards	Dimensional standards	Dimensional range	Dimensions				Straightness	Tube ends
			Tolerance D	Tolerance T	Lengths			
EN	10224	Table 5/Page 40 (Type S D 26,9-139,7)	±1 % min ±0,5 mm is valid for welded pipe too at D = 219,1 mm (method EW and BW)	±12,5 % (D ≤ 219,1 mm) min ±0,4 mm is valid for welded pipe too (method EW and BW)	<ul style="list-style-type: none"> <li>• random</li> <li>• fixed</li> <li>• exact: L = 2–6 m 0 +10 mm *</li> <li>L = 6–12 m 0 +15 mm *</li> <li>L &gt; 12 m 0 + upon agreement</li> </ul>	Allowed deviation max 0,2% L	<ul style="list-style-type: none"> <li>• square cut ends</li> <li>• free from excessive burrs</li> <li>• beveled for T ≥ 3,2 mm, unless otherwise ordered</li> </ul>	
	10255	Table 19/Page 58	See table 19 / page 58 (valid for series H and M) For Type L, L1, L2 see standard	Seamless ±12,5 % Welded • series H, M Type L ±10 % • Type L1, L2 –8 % + delimited by weight				<ul style="list-style-type: none"> <li>• square cut ends</li> <li>• free from excessive burrs</li> <li>• plain ends (no threaded)</li> </ul>
DIN	2440			–12,5 % + delimited by weight		Visually straight		
	2441							
	2442 2460							
BS	1387			–8 % (light series) –10 % (medium and heavy series)				
NF A	49-115 (49-145)			–12,5 % Weight ±10%				
UNI	8863		± 1%, min ± 0,5 mm	–12,5 % + undetermined Weight ±10 %				
	6363							
STN ČSN	42 5710 42 5711		See table19/ page 58	–12,5 % + undetermined Weight ±10 %	<ul style="list-style-type: none"> <li>• random</li> <li>• exact: +5 mm to section max + 100 mm *</li> </ul>	3 mm/m, max 20 mm		
GOST	3262		Usual accuracy: D ≤ 40 mm –0,5/+0,4 mm D > 40 mm –1,0/+0,8 mm	–15 %	<ul style="list-style-type: none"> <li>• random</li> <li>• exact: + 5 mm to section + 10 mm to length *</li> </ul>	D ≤ 20 mm 2 mm/m D > 20 mm 1,5 mm/m		
PN-H	74220		See table19/ page 58		<ul style="list-style-type: none"> <li>• random</li> <li>• fixed</li> <li>• exact: L = 2–6 m 0 +10 mm *</li> <li>L = 6–12 m 0 +15 mm *</li> </ul>			
	74200							
ASTM ASME	A53 SA-53 A795	Table 7/Page 44			See page 18			

\* HF production facilities to 12,7 m + 30 mm (50 mm), over 12,7 m + 100 mm

- The tubes for threading according to standard EN 10255 are preferential delivered as hot finished
- For technological reasons and for reasons to achieve the required dimensional tolerances are as cold drawn and normalized delivered by agreement following tubes:
  - all dimensions with D 10,2 / 13,5 / 17,2 mm
  - at type L and L1 also D 76,1/ 88,9 / 101,6 – only at type L / 114,3 mm
  - all dimensions at type L 2

### List of dimensional standards and technical delivery conditions standards

- EN 10224 Steel pipes, joints and fittings for the conveyance of aqueous liquids including potable water.
- EN 10255 Non-alloy steel tubes suitable for welding or threading.
- DIN 2440 Steel tubes; medium-weight suitable for screwing.
- DIN 2441 Steel tubes; heavy-weight suitable for screwing.
- DIN 2442 Threaded tubes made to quality specifications.
- DIN 2460 Steel tubes for waterworks services.
- NFA 49-115 Hot finished seamless tubes suitable for threading. Dimensions. TDC.
- UNI 6363 Seamless and welded steel tubes for waterworks services.
- UNI 8863 Seamless non-alloy steel tubes suitable for threading in accordance with UNI ISO 7/1.
- BS 1387 Screwed and socketed steel tubes.
- STN 425710 Steel tubes suitable for threading. Medium.
- STN 425711 Steel tubes suitable for threading. Heavy.
- GOST 3262 Water and gas supply steel pipes.
- ASTM A53 Pipe, steel, black and hot-dipped, zinc-coated, welded and seamless. TDC.
- ASTM A795 Black and hot-dipped zinc-coated (galvanized) welded and seamless steel pipe for fire protection use.
- PN-H 74200 Steel tubes for gas list threading.
- JIS G 3452 Carbon steel pipes for ordinary piping (Steel SGP).
- ISO 65 Tubes for screwing

(Fluid-, Water Transportation and House Instalation)

TDC standards	Steel grade			Testing and certificates		Other TDC		
	Name	Condition	Surface	Testing	Certificate	Marking	Surface protection	Packing
10224	L235 L275 L355	Hot finished • as rolled	• visually errorless • adequate to production mode	• cast analysis • tensile test • flattening • leak tightness -hydrost.press. - NDT • visual • dimensions	10204 • non-specific 2.2 • specific 3.1 • agreement	Label on the bundle: • producer • standard • steel • testing- number - controlor • symbol S	Upon agreement	
10255	S 195T (S 235JRH)	Hot finished • as rolled Cold finished (under 21,3) • normalized		• leak tightness -hydrost.press.-NDT • visual • tensile test • bend test • flattening (D > 60,3 mm)	10204 non-specific 2.1	On tube: • producer • series H, M or type L, L1, L2 • symbol S (seamless) Alt. - colour strip • heavy series - red • medium series - blue • type L - green • type L1 - white • type L2 - brown Label on the bundle:		
2440 2441	DIN 17100 St33-2			• leak tightness -hydrost.press.-NDT • visual • tensile test • flattening (D > 60,3 mm) See page 109	50049 2.1 (2.2)	• producer • standard • series H, M or type L, L1, L2 • symbol S (seamless) Alt. - colour strip • heavy series - red • medium series - blue • type L - green • type L1 - white • type L2 - brown Label on the bundle:		
1629	St37.0							
1629	St37.0 St52.0							
1387	1387							
49-115 (49-145)	TU34-1	Hot finished • as rolled Cold finished (under 21,3) • normalized		• leak tightness - hydrost.press. - NDT • visual • tensile test • flattening (D > 60,3 mm)	Test result certificate	• producer • standard • symbol S (seamless) • D (nominal D) • series / type / wall		
8863 6363	Fe330 Fe360 Fe410, Fe510				Mill certificate	Producer's mark		
42 0250	11 353	Hot finished • as rolled Cold finished (under 21,3) • normalized		See page 9				
3262	1050: 10			• leak tightness - hydrost. pressure - NDT • visual • tensile test • flattening (D > 60,3 mm)	10692			
74220 (84023/7)	R35 R45							
74200	12X, 12AL							
A53 A795	Grade A Grade B				See page 19			

**Steels grades, chemical composition and mechanical properties**

(Documents for products delivered according to EN 10224 and EN 10255 are marked with a mandatory conformity mark symbol CE)

Standards	Steel	Chemical composition [%]										Mechanical properties				
		C	Si	Mn	Pmax	Smax	Cr	Ni	Mo	Cu	Other	Re min MPa	Re min ksi	Rm min MPa	Rm max MPa	A5 min %
<b>STN, ČSN</b>																
	11 353	max.0,18			0,050	0,050							235	340	440	25
<b>ASTM</b>																
A 53	GradeA	0,25		0,95	0,050	0,045	0,40	0,40	0,15	0,40	V 0,08	205	30	330		48
	GradeB	0,30		1,20	0,050	0,045	0,40	0,40	0,15	0,40	V 0,08	240	35	415		60
A 795	Grade A	max.0,25		max.0,95	0,035	0,035										
	Grade B	max.0,30		max.1,20	0,035	0,035										
<b>DIN</b>																
2440	St 33-2															
1629	St 37.0	max.0,17			0,040	0,040						235	350	480		25
<b>BS</b>																
1387		max.0,20		max.1,20	0,045	0,045						195	320	460		20
<b>UNI</b>																
8863	Fe 330	max.0,17		max.0,65	0,040	0,040						210	330	520		22
<b>NF A</b>																
49-115	TU 34-1				0,060	0,050						185	320			18
<b>EN</b>																
10224	L 235	max.0,17	max.0,35	max.0,80	0,040	0,040						235	360	500		25
	L 275	max.0,21	max.0,35	max.1,20	0,040	0,040						275	430	570		21
	L 355	max.0,22	max.0,35	max.1,60	0,040	0,040						355	500	650		21
10255	S 195T	max.0,20		max.1,40	0,035	0,030						195	320	520		20
<b>GOST</b>																
380	St0	max.0,23														
1050	10	0,07 - 0,14	0,17 - 0,37	0,35 - 0,65			max.0,15					205	330			31
<b>PN-H</b>																
84023/7	R35	0,07 - 0,16	0,12 - 0,35	0,40 - 0,75	0,040	0,040										
	R45	0,16 - 0,22	0,12 - 0,35	0,60 - 1,2	0,040	0,040										

\*The total composition for elements Cr, Ni, Mo, Cu, V shall not exceed 1,00%.

## Seamless steel tubes for pipelines for combustible fluids

Standards	Dimensional standards	Dimensional range	Dimensions				
			Tolerance D	Tolerance T	Lengths	Straightness	Tube ends
EN ISO ASME ISO	3183 B 36.10M 4200		D < 60,3 mm (2,375 in) -0,80 +0,40 mm (-0,031+0,016in) D ≥ 60,3 ≤ 168,3 mm (2,375 - 6,625in) ± 0,0075 D Tube ends -0,40 +1,60mm Ovality - tube / tube end 0,020D / 0,015 D	Seamless pipes: T ≤ 4mm (0,157 in) -0,5 +0,6 mm (-0,020 +0,024 in) T ≥ 4mm (0,157 in) ≤ 25mm (0,984in) -0,125T +0,150T Pipe wieght - 3,5% +10%	Random nom-min-avege-max [m] 6 - 2,74 - 5,33 - 6,86 9 - 4,11 - 8,00 - 10,29 12 - 4,27 - 10,67 - 13,72 15 - 5,33 - 13,35 - 16,76 [ft] 20 - 9,0 - 17,5 - 22,5 30 - 13,5 - 26,2 - 33,8 40 - 14,0 - 35,0 - 45,0 50 - 17,5 - 43,8 - 55,0	• deviation max 0,2% L • locally max 4 mm/m	• square cut ends • free from excessive burrs • beveled for T ≥ 3,2 mm, unless otherwise ordered • deviation for D ≥ 2 3/8" max. 1/16" (1,6 mm)
DIN	2448	Table 5/Page 40	See page 22				
	2448		D ≤ 200 mm ± 1 % min ± 0,5 mm  Weight -8% +10%	D ≤ 130 mm ± 10 % D > 130 mm ± 12,5 %	• random average 6 m (3-8 m) average 8 m (4-11 m) average 11 m (5,5-14 m) • fixed (±500 mm) • exact	Flexion max 2 mm/m	• square cut ends • free from excessive burrs • beveled according agreement
UNI	7088		See table in Standard  Weight ± 10 %	-12,5 % + non-specific			
API ASME ISO	Spec5L B 36.10M 4200	Table 20 a,b/ Page 59	D < 60,3 mm (2,375 in) -0,80 +0,40 mm (-0,031+0,016in) D ≥ 60,3 ≤ 168,3 mm (2,375 - 6,625in) ± 0,0075 D Tube ends -0,40 +1,60mm Ovality - tube / tube end 0,020D / 0,015 D	Seamless pipes: T ≤ 4mm (0,157 in) -0,5 +0,6 mm (-0,020 +0,024 in) T ≥ 4mm (0,157 in) ≤ 25mm (0,984in) -0,125T +0,150T Pipe wieght - 3,5% +10%	In dependance on diameter • (SRL) - nom. 20 ft (6 m) min - midle - max ft: 9,0 - 17,5 - 22,5 m: 2,74 - 5,33 - 6,86 • (DRL) - nom. 40 ft (12 m) ft: 14,0 - 35,0 - 45,0 m: 4,27 - 10,67 - 13,72	Visually straight, max deviation 0,2 % L	• square cut ends • free from excessive burrs • beveled for T ≥ 3,2 mm, unless otherwise ordered • deviation for D ≥ 2 3/8" max. 1/16" (1,6 mm)

## Steels grades, chemical composition and mechanical properties

Standards	Steel	Chemical composition [%]										Mechanical properties					Carbon equivalent		
		C	Si	Mn	Pmax	Smax	Cr	Ni	Mo	Cu	Other	Re		Rm		A5	CE <sub>IIW</sub> %	CE <sub>PCM</sub> %	
												min MPa	min ksi	min MPa	max MPa	min ksi			min %
<b>API Spec 5L and EN ISO 3183 PSL 1</b>																			
	L210 or A	max.0,22		max.0,90	0,030	0,030					Nb+V max 0,06	210	30	335		48			
	L245 or B	max.0,28		max.1,20	0,030	0,030					Nb+Ti+V max 0,15	245	35	415		60			
	L290 or X42	max.0,28		max.1,30	0,030	0,030					Nb+Ti+V max 0,15	290	42	415		60			
	L320 or X46	max.0,28		max.1,40	0,030	0,030					Nb+Ti+V max 0,15	320	46	435		63			
	L360 or X52	max.0,28		max.1,30	0,030	0,030					Nb+Ti+V max 0,15	360	52	460		67			
	L390 or X56	max.0,28		max.1,40	0,030	0,030					Nb+Ti+V max 0,15	390	57	490		71			
	(L415 or X60)	max.0,28		max.1,30	0,030	0,030					Nb+Ti+V max 0,15	415	60	520		75			
	(L450 or X65)	max.0,28		max.1,40	0,030	0,030					Nb+Ti+V max 0,15	450	65	535		78			
<b>EN ISO 3183 (Annex M) PSL 2</b>																			
	L245NE or BNE	max.0,18	max.0,40	max.1,20	0,025	0,015					d	245 - 440		415	760		22	0,42	0,25
	L290NE or X42NE	max.0,19	max.0,40	max.1,20	0,025	0,015					V max.0,06, Nb max.0,05, Ti max.0,04, d	290 - 440		415	760		21	0,42	0,25
	L360NE or X52NE	max.0,22	max.0,45	max.1,40	0,025	0,015					V max.0,10, Nb max.0,05, Ti max.0,04, d, e	360 - 510		460	760		20	0,42	0,25
	L415NE or X60NE	max.0,23	max.0,45	max.1,40	0,025	0,015					V max.0,10, Nb max.0,05, Ti max.0,04, d, e, f	415 - 565		520	760		18		as agreed
d - 0,015% ≤ Altotal ≤ 0,060%; N ≤ 0,012%; Al/N ≥ 2:1; Cu ≤ 0,25%; Ni ≤ 0,30%; Cr ≤ 0,30%; Mo ≤ 0,10%; e - V+Nb+Ti ≤ 0,15%; f - If agreed Mo ≤ 0,35%																			
<b>DIN</b>																			
1629	St 37.0	max.0,17			0,040	0,040						235		350	480		25		
17172	StE 210.7	max.0,17	max.0,45	min. 0,35	0,040	0,035						210		320	440		26		
	StE 240.7	max.0,17	max.0,45	min. 0,40	0,040	0,035						240		370	490		24		
	StE 290.7	max.0,22	max.0,45	0,50 - 1,10	0,040	0,035						290		420	540		23		
	StE 320.7	max.0,22	max.0,45	0,70 - 1,30	0,040	0,035						320		460	580		21		
	StE 360.7	max.0,22	max.0,55	0,90 - 1,50	0,040	0,035						360		510	630		20		
<b>UNI</b>																			
7088	Fe 35-1	max.0,18			0,045	0,045						240		350	450		25		
	Fe 45-1	max.0,22			0,045	0,045						260		450	550		21		
7287	Fe 320				0,060	0,060								320	530		15		



TDC standards	PSL	Steel grade			Testing and certificates		Other TDC		
		Name	Condition	Surface	Testing	Certificate	Marking	Surface protect.	Packing
3183	PSL 1	L210 or A L245 or B L290 or X42 L320 or X46 L360 or X52 L390 or X56 (L415 or X60) (L450 or X65)	Hot finished: • as rolled • normalising formed • normalized Cold finished • normalized	• visually free from surface defects • adequate to production mode	• cast analysis • tensile test • technological tests • hydrostatic test* • visual • dimensions • NDT* ISO 10893-10 U3/C L (U2/C) (ISO 10 893-3 F3 (F2)) residual magnetism • impact test • tube weight	10 204 3.1 3.2  See also page 7	D ≤ 48,3 mm (1.900) label with information D > 48,3 mm (1.900) – information at tube: • paint stencil • die stamping Data: • manufacturer • specification • compatible standards • dimension • steel(grade and class)	Upon agreement: • temporary • permanent	
3183 (Annex M)		L245NE or BNE L290NE or X42NE L360NE or X52NE L415NE or X60NE	Hot finished • normalising formed (N) • normalized (N) Cold finished • normalized						
2470-1/1629		St37.0	see DIN 1629 – page 23			50049: 3.1.B 3.1.C	• PSL • process (S or E or F) • heat treatment		
2470-2/17172		StE210.7 StE240.7 StE290.7 StE320.7 StE360.7 StE415.7	Hot finished • as rolled Cold finished • normalized		• cast analysis • tensile test • impact test • hydrostatic pressure • visual • dimensions • NDT upon agreement	50049: 3.1.B 3.1.A 3.1.C	• test pressure • certificate (EN) • inspector's mark (EN) Supplementary requirements (API): • color identification API licensees:		
7088		Fe35-1 Fe45-1			• cast analysis • tensile test • impact test • hydrostatic pressure • visual • dimensions • NDT upon agreement		• API monogram • date • length		
Spec5L	PSL 1	L210 or A L245 or B L290 or X42 L320 or X46 L360 or X52 L390 or X56 (L415 or X60) (L450 or X65)	Hot finished • as rolled • normalized (HN) • normalized and tempered (HN) • stress relieved (HS) Cold finished • normalized (HN)		• cast analysis • tensile test • impact test • flattening • hydrotest, • NDT* • dimensions • visual • compliance NACE MR0175	API 5L			

\*HT – mandatory test for all pipes. NDT – mandatory at EN ISO 3183 PSL 2 and API 5L – PSL 2. At PSL 1 according to agreement only.

#### List of dimensional standards and technical delivery conditions standards (Product specification PSL1 according to API)

API Spec5L	Specification for line pipe.	EN ISO 3183	Steel tubes for pipeline transportation system
DIN 2448	Plain end seamless steel tubes. Dimensions.	Annex M – PSL 2	Pipe ordered for European onshore natural gas transmission pipelines
DIN 2460	Steel tubes for waterworks services.	UNI 7088	Unalloyed steel seamless tubes
DIN 2470-1	Steel gas pipelines - pressure up to 16 bar.		- Plain gas tubes for high pressure.
DIN 2470-2	Steel gas pipelines - pressure exceeding 16 bar.		
DIN 17172	Steel pipes for pipelines for the transport of combustible fluids and gases.		

#### Steel designation according to EN ISO 3183 and API Spec 5L:

- PSL 1 – L210 or A  
L – steel for pipeline  
210 – minimum yield strength in N/mm<sup>2</sup>
- PSL 2 – L245R or BR, L245N or BN, L245Q or BQ, L245M or BM  
R – As-rolled  
N – Normalising formed or normalised  
Q – quenched and tempered  
M – thermomechanically formed (only welded pipe)
- PSL 2 pipe ordered for sour service (Annex H)  
L245NS or BNS, L245QS or BQS, L245MS or BMS
- PSL 2 pipe ordered for offshore service (Annex J)  
L245NO or BNO, L245QO or BQO, L245MO or BMO
- PSL 2 pipe ordered for European onshore natural gas transmission pipelines (Annex M)  
L245NE or BNE, L245QE or BQE, L245ME or BME

**Dimensions for threaded tubes according to EN 10255**

**Table19**

Size		Nominal outside diameter D(mm)	Heavy series (H) and Medium series (M)						Type L, L1, L2														
Nominal	DN		D(mm)		Wall thickness T(mm)		Weight (kg/m)		Outside diameter D(mm)				Wall thickness T(mm)			Weight (kg/m)							
			min.	max.	H	M	H	M	min.	L	L1	L2	L	L1	L2	L	L1	L2					
1/8	6	10,2	9,8	10,6	2,6	2,0	0,487	0,404															
1/4	8	13,5	13,2	14,0	2,9	2,3	0,765	0,641	13,2	13,9	13,9	13,6	2,0	2,0	1,8	0,567	0,570	0,515					
3/8	10	17,2	16,7	17,5	2,9	2,3	1,02	0,839	16,7	17,4	17,4	17,1	2,0	2,0	1,8	0,750	0,742	0,670					
1/2	15	21,3	21,0	21,8	3,2	2,6	1,44	1,21	21,0	21,7	21,7	21,4	2,3	2,3	2,0	1,08	1,08	0,947					
3/4	20	26,9	26,5	27,3	3,2	2,6	1,87	1,56	26,4	27,1	27,1	26,9	2,3	2,3	2,3	1,40	1,39	1,38					
1	25	33,7	33,3	34,2	4,0	3,2	2,93	2,41	33,2	34,0	34,0	33,8	2,9	2,9	2,6	2,20	2,20	1,98					
1 1/4	32	42,4	42,0	42,9	4,0	3,2	3,79	3,10	41,9	42,7	42,7	42,5	2,9	2,9	2,6	2,82	2,82	2,54					
1 1/2	40	48,3	47,9	48,8	4,0	3,2	4,37	3,56	47,8	48,6	48,6	48,4	2,9	2,9	2,9	3,25	3,24	3,23					
2	50	60,3	59,7	60,8	4,5	3,6	6,19	5,03	59,6	60,7	60,7	60,2	3,2	3,2	2,9	4,51	4,49	4,08					
2 1/2	65	76,1	75,3	76,6	4,5	3,6	7,93	6,42	75,2	76,0	76,3	76,0	3,2	3,2	3,2	5,75	5,73	5,71					
3	80	88,9	88,0	89,5	5,0	4,0	10,3	8,36	87,9	88,7	89,4	88,7	3,2	3,6	3,2	6,76	7,55	6,72					
4	100	114,3	113,1	115,0	5,4	4,5	14,5	12,2	113,0	113,9	114,9	113,9	3,6	4,0	3,6	9,83	10,8	9,75					

Type L contains also size : nominal 3 1/2, DN = 90, dimension 101,6 x 3,6 mm, tolerances of D = 100,3 – 101,2 mm, weight 8,88 kg/m.

**Permissible specified outside diameter and specified wall thickness according to API Spec 5L**

**Table 20a**

Specified outside diameter D mm (in)	Specified wall thickness	
	Special light sizes t mm (in)	Regular sizes t mm (in)
≥ 10,3 (0,405) to 13,7 (0,540)		≥ 1,7 (0,068) to 2,4 (0,094)
> 13,7 (0,540) to 17,1 (0,675)		≥ 2,2 (0,088) to 3,0 (0,116)
> 17,1 (0,675) to 21,3 (0,840)		≥ 2,3 (0,091) to 3,2 (0,125)
> 21,3 (0,840) to 26,7 (1,050)		≥ 2,1 (0,083) to 7,5 (0,294)
> 26,7 (1,050) to 33,4 (1,315)		≥ 2,1 (0,083) to 7,8 (0,308)
> 33,4 (1,315) to 48,3 (1,900)		≥ 2,1 (0,083) to 10,0 (0,394)
> 48,3 (1,900) to 60,3 (2,375)		≥ 2,1 (0,083) to 12,5 (0,492)
> 60,3 (2,375) to 73,0 (2,875)	≥ 2,1 (0,083) to 3,6 (0,141)	> 3,6 (0,141) to 14,2 (0,559)
> 73,0 (2,875) to 88,9 (3,500)	≥ 2,1 (0,083) to 3,6 (0,141)	> 3,6 (0,141) to 20,0 (0,787)
> 88,9 (3,500) to 101,6 (4,000)	≥ 2,1 (0,083) to 4,0 (0,156)	> 4,0 (0,156) to 22,0 (0,866)
> 101,6 (4,000) to 168,3 (6,625)	≥ 2,1 (0,083) to 4,0 (0,156)	> 4,0 (0,156) to 25,0 (0,984)

**Dimensions of line pipes  
in accordance with former API Spec 5L**

**Table 20b**

NSD (SD)	Outside diameter		Schedule	Wall thickness		Weight	
	[inch]	[mm]		[inch]	[mm]	[lbs/ft]	[kg/m]
0.405 ( $\frac{1}{8}$ )	0.405	10,3	STD	0.068	1,7	0.24	0,36
			XS	0.095	2,4	0.31	0,43
0.540 ( $\frac{1}{4}$ )	0.540	13,7	STD	0.088	2,2	0.43	0,62
			XS	0.119	3,0	0.54	0,79
0.675 ( $\frac{3}{8}$ )	0.675	17,1	STD	0.091	2,3	0.57	0,84
			XS	0.126	3,2	0.74	1,10
0.840 ( $\frac{1}{2}$ )	0.840	21,3	STD	0.109	2,8	0.85	1,28
			XS	0.147	3,7	1.09	1,61
1.050 ( $\frac{3}{4}$ )	1.050	26,7	STD	0.113	2,9	1.13	1,70
			XS	0.154	3,9	1.48	2,19
1.315 (1)	1.315	33,4	STD	0.133	3,4	1.68	2,52
			XS	0.179	4,6	2.17	3,21
1.660 (1 $\frac{1}{2}$ )	1.660	42,2	STD	0.140	3,6	2.27	3,43
			XS	0.191	4,9	3.00	4,51
1.900 (1 $\frac{1}{2}$ )	1.900	48,3	STD	0.145	3,7	2.72	4,07
			XS	0.200	5,1	3.63	5,43
2 $\frac{3}{8}$ (2)	2.375	60,3	STD	0.154	3,9	3.65	5,42
			...	0.172	4,4	4.05	6,07
			...	0.188	4,8	4.39	6,57
			XS	0.218	5,5	5.02	7,43
			...	0.250	6,4	5.67	8,51
			...	0.281	7,1	6.28	9,31
			...	0.156	4,0	4.53	6,81
			...	0.172	4,4	4.97	7,44
2 $\frac{7}{8}$ (2 $\frac{1}{2}$ )	2.875	73,0	...	0.188	4,8	5.40	8,07
			STD	0.203	5,2	5.79	8,69
			...	0.216	5,5	6.13	9,16
			...	0.250	6,4	7.01	10,51
			XS	0.276	7,0	7.66	11,39
			...	0.125	3,2	4.51	6,76
			...	0.141	3,6	5.06	7,57
			...	0.156	4,0	5.57	8,37
3 $\frac{1}{2}$ (3)	3.500	88,9	...	0.172	4,4	6.11	9,17
			...	0.188	4,8	6.65	9,95
			STD	0.216	5,5	7.58	11,31
			...	0.250	6,4	8.68	13,02
			...	0.281	7,1	9.66	14,32
			XS	0.300	7,6	10.25	15,24
			...	0.156	4,0	6.40	9,63
			...	0.172	4,4	7.03	10,55
4 (3 $\frac{1}{2}$ )	4.000	101,6	...	0.188	4,8	7.65	11,46
			STD	0.226	5,7	9.11	13,48
			...	0.250	6,4	10.01	15,02
			...	0.281	7,1	11.16	16,55
			XS	0.318	8,1	12.50	18,68
			...	0.156	4,0	7.24	10,88
			...	0.172	4,4	7.95	11,92
			...	0.188	4,8	8.66	12,96
4 $\frac{1}{2}$ (4)	4.500	114,3	...	0.203	5,2	9.32	13,99
			...	0.219	5,6	10.01	15,01
			STD	0.237	6,0	10.79	16,02
			...	0.250	6,4	11.35	17,03
			...	0.281	7,1	12.66	18,77
			...	0.312	7,9	13.96	20,73
			XS	0.337	8,6	14.98	22,42
			...	0.438	11,1	19.00	28,25
...	0.531	13,5	22.51	33,56			

NSD – Nominal Size Designation

**Notes:** Dimensions 1/8, 1/4 and 3/8 are delivered as cold drawn. The table is valid for tubes for threading and plain end tubes. Values (SD) in brackets were valid until 1995. Since 2000 in the range 10.3 – 48.3 mm Nominal Size Designation and outside diameter D are equal. From 60,3 mm numbers without brackets are valid for Nominal Size Designations and Ds. (under the line) Pipe with T of STD and XS are also designed for threading. See also table 7 page 44 and note at page 58.

**Indicative comparison of steel for pipeline tubes**

**Table 21**

DIN 1629	EN 10208-1	EN ISO 3183	API 5L
(St 33)	L 210GA	L 210	A
St 37.0	L 235GA		
(St 37.0)	L 245GA	L 245	B
St 44.0	L 290GA	L290	X42
St 52.0	L360GA	L360	X52
<b>17172</b>	<b>(10208-2)</b>	<b>3183-2</b>	
StE 210.7			( A )
StE 240.7	L 245NB	L245NE	BN
StE 290.7	L 290NB	L290NE	X42N
StE 320.7		L320N	X46N
StE 360.7	L 360NB	L360NE	X52N
StE 385.7		L390N	X56N
StE 415.7	L 415NB	L415NE	X60N
StE 445.7	L 450NB		X65
StE 480.7	L 485NB		X70
	L 555NB		X80

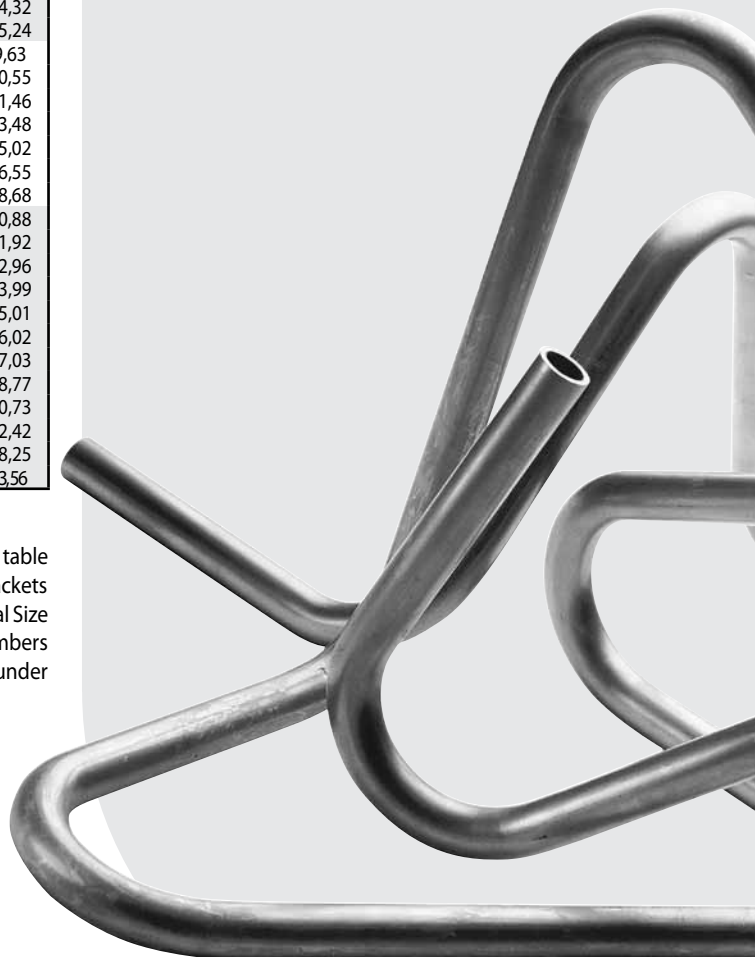

## Casing and tubing - tube for oils

The tubes are used in oil and gas industry.

### List of standards for casing and tubing

Standard	Dimensional standard	Dimensions	TDC	Steel grade
API	API Spec 5CT	Tab 22 Page 61	API 5CT	H40, J55, K55, N80

### Dimensional standard and technical delivery condition standard

API 5CT Specification for casing and tubing (ISO 11960:2004)

#### Dimensions and tolerances

Dimensions are given in Table 22. Tubes are delivered mainly as hot rolled.

#### Tube lengths (Tubing)

Group 1: 6,10–7,32 m (20–24 ft)  
 Group 2: 8,53–9,75 m (28–32 ft)  
 Group 3: 11,58–12,80 m (38–42 ft)

#### Tube lengths Casing

Group 1: 4,88–7,62 m (16–25 ft)  
 Group 2: 7,62–10,36 m (25–34 ft)  
 Group 3: 10,36–14,64 m (34–48 ft)

#### Straightness

Tubes are visually straight.

#### Tube ends

Plain tube ends without threading and flanges.

#### Steel grade

Steel grades are given in survey table.

#### Final supply conditions and surface condition

Hot finished tubes are not heat treated. Surface of tubes corresponded to the method of tube manufacturing. Normalization (N) only upon agreement.

#### Pipe and bundle marking

- stamp marking
- stencil marking (Ink Jet)
- colour bands

Bundles are marked with one or more metal tags with required information.

#### Surface protection

The pipes are supplied either uncoated or with manufacturer's standard mill coating. Upon request the tube ends could be plugged with plastic caps.

#### Packaging

Pipes are packed in round bundles with weight 1000–3500 kg. Each bundle is bounded with 4 steel strips.

#### Testing

Tubes are tested according to requirements of standard API 5CT, eventually additional agreed tests.

#### Certified test report

API Spec 5CT  
 DIN 50049 – 3.1.B  
 EN 10204 – 3.1

### Steels grades, chemical composition and mechanical properties (Group 1 and Type 1 according API Spec 5CT)

Standards	Steel	Chemical composition [%]										Mechanical properties					
		C	Si	Mn	Pmax	Smax	Cr	Ni	Mo	Cu	Other	Re min MPa	Re min ksi	Rm min MPa	Rm max MPa	A5 min ksi	A5 min %
API Spec5CT																	
	Grade H40	–	–	–	0,030	0,030							276	40	414		60
	Grade J55	–	–	–	0,030	0,030							379	55	517		75
	Grade K55	–	–	–	0,030	0,030							379	55	655		95
	Grade N80-1				0,030	0,030							552	80	689		100

Tubing is delivered according of requirements PSL 1. Level PSL 2 and PSL 3 (Annex H of API 5CT) according agreement.

Dimensions of oil tubes

Table 22

Size	Outside diameter		Size	Wall thickness		Weight	
	[inch]	[mm]		[inch]	[mm]	[lbs/ft]	[kg/m]
<b>TUBING (PLAIN END)</b>							
1,050	1,050	26,7	1,14	0,113	2,87	1,13	1,70
		(26,67)	1,48	0,154	3,91	1,48	2,19
1,315	1,315	33,4	1,70	0,133	3,38	1,68	2,52
		(33,40)	2,19	0,179	4,55	2,17	3,21
1,660	1,660	42,16	2,09	0,125	3,18	2,05	3,05
		(42,2)	2,30	0,140	3,56	2,27	3,43
			3,03	0,191	4,85	3,00	4,51
1,900	1,900	48,26	2,40	0,125	3,18	2,37	3,55
		(48,3)	2,75	0,145	3,68	2,72	4,09
			3,65	0,200	5,08	3,63	5,41
2 3/8	2,375	60,32	4,00	0,167	4,24	3,94	5,83
		(60,3)	4,60	0,190	4,83	4,44	6,63
			5,80	0,254	6,45	5,75	8,56
2 7/8	2,875	73,02	6,40	0,217	5,51	6,17	9,15
		(73,0)	7,80	0,276	7,01	7,67	11,39
			8,60	0,308	7,82	8,45	12,57
3 1/2	3,500	88,9	7,70	0,216	5,49	7,58	11,31
		(88,90)	9,20	0,254	6,45	8,81	13,20
			10,20	0,289	7,34	9,92	14,76
4	4,000	101,6	9,50	0,226	5,74	9,12	13,56
		(101,60)	10,70	0,262	6,65	10,47	15,57
			13,20	0,330	8,38	12,95	19,27
4 1/2	4,500	114,3	12,60	0,271	6,88	12,25	18,22
		(114,30)	15,20	0,337	8,56	15,00	22,32
			17,00	0,380	9,65	16,77	24,90
<b>CASING (WITHOUT THREADING)</b>							
4 1/2	4,500	114,3	9,50	0,205	5,21	9,41	14,01
		(114,30)	10,50	0,224	5,69	10,24	15,21
			11,60	0,250	6,35	11,36	16,90
			13,50	0,290	7,37	13,05	19,41
			15,10	0,337	8,56	15,00	22,29

**Notes:**

Tubes of D 2.063 in (52,4 mm), 5 inch (127 mm) and 5 1/2 inch (139,7 mm) upon agreement. Dimensions in brackets are from edition API 5CT – 2005.

**Tolerance of dimensions:**

Tolerance      D < 4 1/2 inch = ±0,79 mm (±0,031 inch)  
                     D ≥ 4 1/2 inch = -0,5 % +1,0 % D  
                     T = -12,5 % (+ limited by weight)  
                     weight (1 tube) = -3,5 % +6,5 %

## Standard precision seamless steel tubes, cold drawn

Standards	Dimensional standards	Dimensional range	Dimensions				
			Tolerance D	Tolerance T	Lengths	Straightness	Tube ends
EN	10305-1		See dimensional tables (Inside diameter tolerance is also shown in table) • other tolerances upon agreement • possibility to shift tolerance • by heat treated tubes increasing of tolerance range • ovality included in D tolerances • eccentricity included in T tolerances	$\pm 10\%$ min $\pm 0,1$ mm (Applied for ordering by: • D x T • d x T)	<ul style="list-style-type: none"> <li>random 3–7 (9) m</li> <li>fixed with tolerance <math>\pm 500</math> mm</li> <li>exact with tolerance 0 + upon agreement</li> <li>max length 18 m – upon agreement</li> </ul>	<ul style="list-style-type: none"> <li>D &gt; 15 mm</li> <li>total deviation: ReH &lt; 500 MPa 0,0015 L</li> <li>ReH &gt; 500 MPa 0,002 L</li> <li>local deviation max 3 mm/m</li> <li>D do 15 mm – upon agreement</li> </ul>	<ul style="list-style-type: none"> <li>square cut ends</li> <li>free from excessive burrs</li> <li>plain ends</li> <li>possibility – tol. of D outside values in table (cutting method)</li> <li>specified end finishing</li> </ul>
DIN	2391-1		See notes at page 64		Value for exact lengths: L $\leq$ 0,5 m 0 +2 mm L = 0,5–2 m 0 +3 mm L = 2–5 m 0 +5 mm L = 5–7 (8) m 0 +10 mm L $\geq$ 7 (8) m agreement (0 +15 mm) Value in brackets valid for NF A	<ul style="list-style-type: none"> <li>D &gt; 15 mm 0,25% L</li> <li>locally 3 mm/m</li> </ul>	
BS	6323/4	Table 25/Page 69 Table 26/Page 70 Table 23/Page 68 (Other dimensions upon agreement)					
NF A	49-310  49-312		Quality range: A - usual tolerances B - reduced tolerances C - cylinder tubes D - special requirements	D $\leq$ 5 mm $\pm 20\%$ D = 5–8 mm $\pm 15\%$ D > 8 mm $\pm 10\%$ min $\pm 0,12$ mm			
UNI	7945		See dimensional tables (Inside diameter tolerance is also shown in table) • other tolerances upon agreement • possibility to shift tolerance • by heat treated tubes increasing of tolerance range • ovality included in D tolerances • eccentricity included in T tolerances	$\pm 10\%$ min $\pm 0,1$ mm (Applied for ordering by: • D x T • d x T)			

### List of dimensional standards and technical delivery conditions standards

EN 10305-1	Steel tubes for precision applications. Part 1: Seamless cold drawn tubes.
DIN 2391	Seamless precision steel tubes. Part 1: Dimensions. Part 2: TDC.
BS 6323	Seamless and welded steel tubes for automobile, mechanical and general engineering purposes. Part 1: General requirements. Part 4: Specific requirements for cold finished seamless steel tubes.
NFA 49-310	Seamless precision tubes for mechanical application.
NFA 49-312	Seamless tubes from fine grain steels with improved machinability for mechanical machined parts
UNI 7945	Plain end seamless precision steel tubes.
ISO 3304	Plain end seamless precision steel tubes - TDC.



TDC standards	Steel grade			Testing and certificates		Marking	Other TDC	
	Name	Condition	Surface	Testing	Certificate		Surface protection	Packing
10305-1 (Other TDC upon agreement)	(E215) E235 E355 E255 26Mn5 C35E, C45E 25CrMo4 42CrMo4 (Other steel upon agreement)	Cold finished Symbol for steel condition: + C + LC + SR + A + N	Outside and inside surface smooth Roughness $\leq 4 \mu\text{m}$ Tubes in condition +C and +LC with layers of lubricant and lubricant carrier	Non-specific Specific: • product analysis • tensile test • dimensions • visual • optional - upon agreement (including NDT)	10204: • 2.2 • 3.1  See also page 17	Label with data on bundle Upon agreement letter spraying on tube: • producer • dimension • standard • steel grade • cast • test style • identification number by specific testing	Temporary upon agreement - Possibilities: • manufacturer's decision • upon agreement • without protection	Bundle with section: • round • hexagonal  Max weight 2000 kg
2391-2 (Other TDC upon agreement)	St35 St45 St52 (Other steel upon agreement)	Cold finished Symbol for steel condition: BK BKW BKS GBK NBK		Grade A of quality Grade C of quality • dimensions • visual • tensile test • flattening* • drift expanding* • optional - upon agreement	50049/2.2 3.1.B			
6323/1,4	CFS 3 CFS 4 CFS 5 CFS 6 CFS 7 CFS 8	Cold finished Symbol for steel condition: BK BKW GBK NBK		• product analysis • tensile test • flattening • leak tightness - upon agreement	Test results			
49-310  49-312	TU37b TU52b TU20MV6  S 470M S 450MG2	Symbol for steel condition: BK BKW BK + S GBK NBK		• tensile test • flattening* • drift expanding* • dimensions • visual • other tests - upon agreement	49-001 • non-specific - 2.2 • specific - 3.1.B - 3.1.C			
7945	Fe280 Fe320 Fe360 Fe410 Fe490	Cold finished Symbol for steel condition: BK BKW GBK NBK		Non-specific Specific: • product analysis • tensile test • dimensions • visual • optional - upon agreement (including NDT)	10204: • 2.2 • 3.1			

Note: \* technological test for heat-treated tubes only



### Designation of steels for precision tubes according to EN:

- machining steel tubes:
  - steel E355 + AR, E 355 + N
    - E – steel for machine part
    - 355 – minimum yield strength
    - + AR – heat treatment not applied, + N – normalized or normalising formed
  - steel 20MnV6
    - steel designated by chemical composition – guaranteed mean C content 0,20% guaranteed content of Mn and V
    - + AR – heat treatment not applied, + N – normalized or normalising formed
- steels for machine parts
  - steels for working without next heat treatment
    - non-alloy steel E 235, E275, E315, E355
    - condition +AR or +N
  - steels with specified impact properties (fine grain) E275K2, E355K2
    - K2 – minimum average absorbed energy 40J (K) at a test temperature of –20 °C
  - steels for heat and chemical-heat treatment of parts after working
    - steel C22E
      - C – steel with C content 0,22%, E – assignment on controlled mean of S and P
    - steel 38Mn6
      - guaranteed mean C content and guaranteed Mn content

## ►►► Precision cold drawn seamless standard steel tubes

Standards	Dimensional standards	Dimensional range	Dimensions				Straightness	Tube ends
			Tolerance D	Tolerance T	Lengths			
STN ČSN	(42 6710)	Delivery upon agreement	see page 36					<ul style="list-style-type: none"> <li>• square cut ends</li> <li>• free from excessive burrs</li> <li>• plain ends</li> </ul>
	42 6711		$D \leq 30 \text{ mm } \pm 0,20 \text{ mm}$ $D = 30\text{--}50 \text{ mm } \pm 0,30 \text{ mm}$ $D = 50\text{--}200 \text{ mm } \pm 0,8 \%$	$D \leq 10 \text{ mm } \pm 0,20 \text{ mm}$ $D > 10 \text{ mm}, T \leq 1 \text{ mm } \pm 0,12 \text{ mm}$ $D > 10 \text{ mm}, T = 1\text{--}3 \text{ mm } -10\% +12\%$ $D > 10 \text{ mm}, T > 3 \text{ mm } \pm 10 \%$	<ul style="list-style-type: none"> <li>• random 3–7 (9) m</li> <li>• fixed with tolerance <math>\pm 500 \text{ mm}</math></li> <li>• exact with tolerance 0 + upon agreement</li> <li>• max length 18 m</li> <li>- upon agreement</li> </ul>	$D \leq 15 \text{ mm}$ Straightened $3 \text{ mm/m}$ $\pm 1$ Precise straightened $1,5 \text{ mm/m} \cdot +2$ (second number behind RN)		
	42 6712		$D \leq 30 \text{ mm } \pm 0,10 \text{ mm}$ $D = 30\text{--}40 \text{ mm } \pm 0,15 \text{ mm}$ $D = 40\text{--}50 \text{ mm } \pm 0,20 \text{ mm}$ $D = 50\text{--}200 \text{ mm } \pm 0,5 \%$ (From $d = 18 \text{ mm}$ possible to order by d)	$D \leq 10 \text{ mm } \pm 0,20 \text{ mm}$ $D > 10 \text{ mm}, T \leq 1 \text{ mm } \pm 0,10 \text{ mm}$ $D > 10 \text{ mm}, T > 1 \text{ mm } \pm 10 \%$	<ul style="list-style-type: none"> <li>• max length 18 m</li> <li>- upon agreement</li> </ul>	$L \leq 3 \text{ m } 0 + 5 \text{ mm}$ $L > 3 \text{ m } 0 + 10 \text{ mm}$		
GOST	8734	Table 25/Page 69 Table 26/Page 70 Table 23/Page 68 (Other dimensions upon agreement)	$D = 5\text{--}10 \text{ mm } \pm 0,15 \text{ mm}$ $D = 10\text{--}30 \text{ mm } \pm 0,30 \text{ mm}$ $D = 30\text{--}50 \text{ mm } \pm 0,4 \text{ mm}$ $D > 50 \text{ mm } \pm 0,8 \%$	$T \leq 1 \text{ mm } \pm 0,12 \text{ mm}$ $T = 1\text{--}5 \text{ mm } \pm 10 \%$ $T > 5 \text{ mm } \pm 8 \%$		Flexion max 1,5 mm/m		
	9567		See dimensional tables (Inside diameter tolerance is also shown in table) <ul style="list-style-type: none"> <li>• other tolerances upon agreement</li> <li>• possibility to shift tolerance</li> <li>• by heat treated tubes increasing of tolerance range</li> <li>• ovality included in D tolerances</li> <li>• eccentricity included in T tolerances</li> </ul>	$D = 5\text{--}108 \text{ mm}$ $T = 0,2\text{--}0,8 \text{ mm } \pm 0,05 \text{ mm}$ $T = 0,8\text{--}5 \text{ mm } \pm 7,5 \%$ $T > 5 \text{ mm } \pm 6 \%$				
	12132		Quality range: <ul style="list-style-type: none"> <li>• usual</li> <li>• increased</li> <li>• high</li> </ul> see article 1.10 of standard					
PN-H	74240 (74220)		See dimensional tables (Inside diameter tolerance is also shown in table) <ul style="list-style-type: none"> <li>• other tolerances upon agreement</li> <li>• possibility to shift tolerance</li> <li>• by heat treated tubes increasing of tolerance range</li> <li>• ovality included in D tolerances</li> <li>• eccentricity included in T tolerances</li> </ul>	$\pm 10 \%$ min $\pm 0,1 \text{ mm}$ Applied for ordering by: <ul style="list-style-type: none"> <li>• D x T</li> <li>• D x T)</li> </ul>	<ul style="list-style-type: none"> <li>• random 3–7 (9) m</li> <li>• fixed with tolerance <math>\pm 500 \text{ mm}</math></li> <li>• exact with tolerance 0 + upon agreement</li> <li>• max length 18 m</li> <li>- upon agreement</li> </ul>	<ul style="list-style-type: none"> <li>• total deviation: ReH &lt; 500 MPa 0,0015 L</li> <li>ReH &gt; 500 MPa 0,002 L</li> <li>• local deviation max 3 mm/m</li> </ul>		
ASTM	A519				See page 18			
JIS	G3445				See page 18			

### Notes:

1. Tolerances of outside or inside diameter are not given like % of diameter as with rolled tubes, but they are usually a part of dimensional tables. Values in Table 25 are taken from EN 10305-1. Exact tolerance values of tubes according to other standards are given in appropriate standards.
2. Tubes shall be ordered: D x d, D x T, d x T (d = inside diameter). The tolerances are valid for these two ordered values.
3. Tubes for mechanical and pressure purposes (page 16–47) upon agreement can be delivered as precision according to dimensional standards for precision tubes.
4. Precision tubes can be delivered also upon bilaterally agreed TDC and technical specifications.
5. Ovality and eccentricity see page 4.

### List of dimensional standards and technical delivery conditions standards

STN 42 0260	ČSN 42 0260 Cold drawn precision seamless steel tubes from steel class 10 to 16.
STN 42 6710	ČSN 42 6710 Cold drawn seamless tubes with normal tolerances. Dimensions.
STN 42 6711	ČSN 42 6711 Precision seamless steel tubes. Dimensions.
STN 42 6712	ČSN 42 6712 Precision seamless steel tubes with increased accuracy. Dimensions.
GOST 8733	Seamless steel tubes cold and hot deformed. TDC.
GOST 8734	Seamless steel tubes cold deformed. Dimensions.
GOST 12132	Electrowelded and seamless steel tubes for automotive and bicycle industries.
GOST 21729	Cold deformed and hot deformed structural carbon and alloyed steel tubes.
PN-H 74220	Seamless steel cold drawn or rolled tubes for general purposes.
PN-H 74240	Seamless cold drawn precision steel tubes.
ASTM A519	Seamless carbon and alloy steel mechanical tubing.
JIS G 3445	Carbon steel tubes for machine structural purposes.
GOST 9267	Precision seamless steel tubes. Dimensions.

TDC standards	Name	Steel grade		Testing and certificates		Marking	Other TDC		
		Condition	Surface	Testing	Certificate		Surface protection	Packing	
42 0260	11 353 11 453 11 503 11 523 11 550 11 650 12 040 12 050 12 060	Cold finished Symbol for steel condition: .0 No heat treatment .1 Normalized  Other conditions upon agreement	.0+ - scaled .1+ - pickled .2+ - free of scale .3+ - bright .4+ - metallic clean .9+ - special agreement (first number behind DS)	• dimensions • tensile test .1, .2, .4 • hardness .3 • flattening .4 • drift expanding .4 • leak tightness .2, .4 • NDT - upon agreement	.1+ - certificate .2+ - inspection .9+ - agreement first digit after TDC	Label with data on bundle Data: • manufacturer • order • dimension • steel • condition • quantity • colour strap on tube	Temporary upon agreement	Bundle with section: • round • hexagonal  Max weight 2000 kg	
8733 21729	1050: 10 20 35 45 4543: 10G2 15ChM 19281: 09G2S	Cold finished Symbol for steel condition: No heat treatment Normalized  Other conditions upon agreement		• product analysis • dimensions • visual • hardness • leak tightness			GOST 10692		
74240 (74220)	84018: 18G2A 18G2 84019: 10 20 35 45 55 84023/7: R35 R45 R55	Cold finished Symbol for steel condition: BK BKW GBK NBK							
A519	See page 19								
G3445	See page 19								

## Steels grades, chemical composition and mechanical properties

Standards	Steel	Chemical composition [%]										Mechanical properties					
		C	Si	Mn	Pmax	Smax	Cr	Ni	Mo	Cu	Other	Re min MPa	min ksi	min MPa	Rm max MPa	min ksi	A5 min %
<b>STN, ČSN</b>																	
	11 353	max.0,18			0,050	0,050							235		340	440	25
	11 453	max.0,24			0,050	0,050							265		441	539	21
	11 503	max.0,18	max.0,40	max.1,40	0,035	0,035	max.0,30	max.0,30			max.0,30	Nb 0,015-0,08	355		490	630	22
	11 523	max.0,20	max.0,55	max.1,60	0,050	0,045						Al min.0,015	353		510	628	23
	11 550	max.0,40			0,050	0,050							314		539	637	17
	11 650	max.0,55			0,050	0,050							363		637	735	12
	12 040	0,32-0,40	0,15-0,40	0,50-0,80	0,040	0,040	max.0,25	max.0,30			max.0,30		295		530	530	18
	12 050	0,42-0,50	0,17-0,37	0,50-0,80	0,040	0,040	max.0,25	max.0,30			max.0,30		325		590	590	17
	12 060	0,52-0,60	0,15-0,40	0,50-0,80	0,040	0,040	max.0,25	max.0,30			max.0,30		375		640	640	13
<b>ASTM</b>																	
A 53*	GradeA	0,25		0,95	0,050	0,045	0,40	0,40	0,15	0,40	V 0,08		205	30	330		48
	GradeB	0,30		1,20	0,050	0,045	0,40	0,40	0,15	0,40	V 0,08		240	35	415		60
A 519	MT 1010	0,05-0,15		0,30-0,60	0,040	0,050											
	MT 1015	0,10-0,20		0,30-0,60	0,040	0,050											
	MT X 1015	0,10-0,20		0,60-0,90	0,040	0,050											
	MT 1020	0,15-0,25		0,30-0,60	0,040	0,050											
	MT X 1020	0,15-0,25		0,70-1,00	0,040	0,050											
	1008	max.0,10		0,30-0,50	0,040	0,050											
	1010	0,08-0,13		0,30-0,60	0,040	0,050											
	1012	0,10-0,15		0,30-0,60	0,040	0,050											
	1015	0,13-0,18		0,30-0,60	0,040	0,050											
	1016	0,13-0,18		0,60-0,90	0,040	0,050											
	1017	0,15-0,20		0,30-0,60	0,040	0,050											
	1018	0,15-0,20		0,60-0,90	0,040	0,050											
	1019	0,15-0,20		0,70-1,00	0,040	0,050											
	1020	0,18-0,23		0,30-0,60	0,040	0,050							221	32	345		50
	1021	0,18-0,23		0,60-0,90	0,040	0,050											
	1022	0,18-0,23		0,70-1,00	0,040	0,050											
	1025	0,22-0,28		0,30-0,60	0,040	0,050							241	35	379		55
	1026	0,22-0,28		0,60-0,90	0,040	0,050											
	1030	0,28-0,34		0,60-0,90	0,040	0,050											
	1035	0,32-0,38		0,60-0,90	0,040	0,050							276	40	448		65
	1040	0,38-0,44		0,60-0,90	0,040	0,050											
	1045	0,43-0,50		0,60-0,90	0,040	0,050							310	45	517		75
	1050	0,48-0,55		0,60-0,90	0,040	0,050							345	50	552		80
	1518	0,15-0,21		1,10-1,40	0,040	0,050											
	1524	0,19-0,25		1,35-1,65	0,040	0,050											
	1541	0,36-0,44		1,35-1,65	0,040	0,050											
<b>DIN</b>																	
1629	St 37.0	max.0,17			0,040	0,040							235		350	480	25
	St 44.0	max.0,21			0,040	0,040							275		420	550	21
	St 52.0	max.0,22	max.0,55	max.1,60	0,040	0,035						Al min.0,020	355		500	650	21
1630	St 37.4	max.0,17	max.0,35	min.0,35	0,040	0,040						Al min.0,020	235		350	480	25
	St 44.4	max.0,20	max.0,35	min.0,40	0,040	0,040						Al min.0,020	275		420	550	21
	St 52.4	max.0,22	max.0,55	max.1,60	0,040	0,035						Al min.0,020	355		500	650	21
2391-2	St 35	max. 0,17	max. 0,35	min.0,40	0,025	0,025							235		340	470	25
	St 45	max. 0,21	max. 0,35	min.0,40	0,025	0,025							255		440	570	21
	St 52	max. 0,22	max. 0,35	max. 1,60	0,025	0,025							355		490	630	22
17204	C22	0,17-0,24	max.0,40	0,30-0,60	0,045	0,045							260		420	550	21
	Ck22	0,17-0,24	max.0,40	0,30-0,60	0,035	0,035							260		420	550	21
	Cm22	0,17-0,24	max.0,40	0,30-0,60	0,035	0,035							260		420	550	21
	C35	0,32-0,39	max.0,40	0,50-0,80	0,045	0,045							300		520	670	17
	Ck35	0,32-0,39	max.0,40	0,50-0,80	0,035	0,035							300		520	670	17
	Cm35	0,32-0,39	max.0,40	0,50-0,80	0,035	0,035							300		520	670	17
	C45	0,42-0,50	max.0,40	0,50-0,80	0,045	0,045							350		610	760	16
	Ck45	0,42-0,50	max.0,40	0,50-0,80	0,035	0,035							350		610	760	16
	Cm45	0,42-0,50	max.0,40	0,50-0,80	0,035	0,035							350		610	760	16
	34CrMo4	0,30-0,37	max.0,40	0,60-0,90	0,035	0,035	0,90-1,20		0,15-0,30				355		610	760	16
17210	C15	0,12-0,18	max.0,40	0,30-0,60	0,045	0,045											
	Ck15	0,12-0,18	max.0,40	0,30-0,60	0,035	0,035											
	Cm15	0,12-0,18	max.0,40	0,30-0,60	0,035	0,035											
	16MnCr5	0,14-0,19	max.0,40	1,00-1,30	0,035	0,035	0,80-1,10										
<b>BS</b>																	
6323	CFS 3	max.0,20	max.0,35	0,60-1,00	0,050	0,050							215		360		24
	CFS 4	max.0,25	max.0,35	max.1,20	0,050	0,050							235		410		22
	CFS 5	max.0,23	max.0,50	max.1,50	0,050	0,050							340		490		20
	CFS 6	0,30-0,40	max.0,35	0,50-0,90	0,050	0,050							280		460		21
	CFS 7	0,20-0,30	max.0,35	1,20-1,50	0,050	0,050							-		-		-
	CFS 8	0,40-0,55	max.0,35	0,50-0,90	0,050	0,050							340		540		18
<b>UNI</b>																	
663	Fe 35-1	max.0,18	-	-	0,045	0,045							240		350	450	25
	Fe 45-1	max.0,22	-	-	0,045	0,045							260		450	550	21
	Fe 55-1	max.0,36	-	-	0,045	0,045							340		550	650	17
	Fe 35-2	max.0,17	0,10-0,35	min.0,40	0,035	0,035							240		350	450	28
	Fe 45-2	max.0,22	0,10-0,35	min.0,50	0,035	0,035							260		450	550	23
	Fe 55-2	max.0,36	0,10-0,35	min.0,50	0,035	0,035							340		550	650	18
7945	Fe 280	max. 0,13		max. 0,60	0,050	0,050							155		280		25
	Fe 320	max. 0,16		max. 0,70	0,050	0,050							195		320		25
	Fe 360	max. 0,17	max. 0,35	max. 0,80	0,050	0,050							215		360		24
	Fe 410	max. 0,21	max. 0,35	max. 1,20	0,050	0,050							235		410		22
	Fe 490	max. 0,23	max. 0,35	max. 1,50	0,050	0,050							285		490		21
<b>NF A</b>																	
49-310	TU 37-b	max.0,18	max.0,35	max. 0,80	0,040	0,040							240		360	500	25
	TU 52-b	max.0,20	max.0,50	max. 1,50	0,040	0,040							350		510	650	22
	TU 20 MV6	max. 0,22	max. 0,50	max. 1,70	0,040	0,040						V max. 0,15	410		550	700	22
49-312	S470M	0,15-0,22	max. 0,50	1,00-1,70	0,030												



Standards	Steel	Chemical composition [%]										Mechanical properties					
		C	Si	Mn	Pmax	Smax	Cr	Ni	Mo	Cu	Other	Re min MPa	min ksi	min MPa	Rm max MPa	min ksi	A5 min %
<b>EN</b>																	
10216-1	P195TR1	max.0,13	max.0,35	max.0,70	0,030	0,020	max.0,30	max.0,30	max.0,08	max.0,30	Nb, Ti, V	195		320	440	27	
	P195TR2	max.0,13	max.0,35	max.0,70	0,030	0,015	max.0,30	max.0,30	max.0,08	max.0,30	Al min. 0,02 Nb, Ti, V	195		320	440	27	
	P235TR1	max.0,16	max.0,35	max.1,20	0,030	0,020	max.0,30	max.0,30	max.0,08	max.0,30	Nb, Ti, V	235		360	500	25	
	P235TR2	max.0,16	max.0,35	max.1,20	0,030	0,015	max.0,30	max.0,30	max.0,08	max.0,30	Al min. 0,02 Nb, Ti, V	235		360	500	25	
	P265TR1	max.0,20	max.0,40	max.1,40	0,030	0,020	max.0,30	max.0,30	max.0,08	max.0,30	Nb, Ti, V	265		410	570	21	
	P265TR2	max.0,20	max.0,40	max.1,40-	0,030	0,015	max.0,30	max.0,30	max.0,08	max.0,30	Al min. 0,02 Nb, Ti, V	265		410	570	21	
10216-3	P355N	max.0,20	max.0,50	0,90-1,70	0,030	0,020	max.0,30	max.0,50	max.0,08	max.0,30	Al min. 0,02 Nb, Ti, V	355		490	650	22	
10294-1 10297-1	E235	max.0,18	max.0,35	max.1,20	0,045	0,045						235		360		25	
	E275	max.0,21	max.0,35	max.1,40	0,045	0,045						275		410		22	
	E315	max.0,21	max.0,30	max.1,50	0,045	0,045						315		450		21	
	E355	max.0,22	max.0,55	max.1,60	0,045	0,045						355		490		20	
	E275K2	max.0,20	max.0,40	max.1,40	0,035	0,030	max.0,30	0,30	max.0,10	max.0,35	V max.0,05	275		410			
	E355K2	max.0,20	max.0,50	max.1,65	0,035	0,030	max.0,30	0,50	max.0,10	max.0,35	V max.0,12	355		490		20	
	C22	0,17-0,24	max.0,40	0,40-0,70	0,045	0,045						260		420		21	
	C35	0,32-0,39	max.0,40	0,50-0,80	0,045	0,045						300		520		17	
	C45	0,42-0,50	max.0,40	0,50-0,80	0,045	0,045						350		610		16	
	C60	0,57-0,65	max.0,40	0,60-0,90	0,045	0,045						390		720		13	
	38Mn6	0,34-0,42	max.0,35	1,40-1,65	0,035	0,035						400		670		14	
	20MnV6	0,16-0,22	0,10-0,50	1,30-1,70	0,035	0,040					V max.0,15	420		600		19	
	10305-1	E 235	max. 0,17	max. 0,35	max. 1,20	0,025	0,025						235		340	480	25
		E 355	max. 0,22	max. 0,55	max. 1,60	0,025	0,025						355		490	630	22
E 255		max.0,21	max.0,35	0,40 - 1,10	0,025	0,025						255		440	570	21	
26Mn5		0,20-0,30	max. 0,40	1,20-1,50	0,035	0,035											
C 35E		0,32-0,39	max. 0,40	0,50-0,80	0,035	0,035	max. 0,40		max. 0,10			280		460		21	
C 45E		0,42-0,55	max. 0,40	0,50-0,80	0,035	0,035	max. 0,40		max. 0,10			340		540		18	
E 410 (20V1)		0,16-0,22	0,10-0,50	1,30-1,70	0,030	0,035					V 0,08-0,15	410		550	700	22	
26Mo2		0,22-0,29	max. 0,40	max. 1,50	0,035	0,035		max. 0,40	0,15-0,25								
25CrMo4		0,22-0,29	max. 0,40	0,60-0,90	0,035	0,035	0,90-1,20	max. 0,40	0,15-0,30								
42CrMo4		0,38-0,45	max. 0,40	0,60-0,90	0,035	0,035	0,90-1,20	max. 0,40	0,15-0,30								
<b>GOST</b>																	
1050	10	0,07-0,14	0,17-0,37	0,35-0,65			max.0,15					205		330		31	
	20	0,17-0,24	0,17-0,37	0,35-0,65			max.0,25					245		410		25	
	35	0,32-0,40	0,17-0,37	0,50-0,80			max.0,25					315		530		20	
	45	0,42-0,50	0,17-0,37	0,50-0,80			max.0,25					355		600		16	
19281	09G2S	max.0,12	0,50-0,80	1,30-1,70			max.0,30	max.0,30		max.0,30		345		490		21	
<b>JIS</b>																	
G 3445	STKM 11A	max.0,12	max.0,35	max.0,60	0,040	0,040								290		35	
	STKM 12A	max.0,20	max.0,35	max.0,60	0,040	0,040						175		340		35	
	STKM 12B	max.0,20	max.0,35	max.0,60	0,040	0,040						275		390		25	
	STKM 12C	max.0,20	max.0,35	max.0,60	0,040	0,040						355		470		20	
	STKM 13A	max.0,25	max.0,35	0,30-0,90	0,040	0,040						215		370		30	
	STKM 13B	max.0,25	max.0,35	0,30-0,90	0,040	0,040						305		440		20	
	STKM 13C	max.0,25	max.0,35	0,30-0,90	0,040	0,040						380		510		15	
	STKM 14A	max.0,30	max.0,35	0,30-1,00	0,040	0,040						245		410		25	
	STKM 14B	max.0,30	max.0,35	0,30-1,00	0,040	0,040						355		500		15	
	STKM 14C	max.0,30	max.0,35	0,30-1,00	0,040	0,040						410		550		15	
	STKM 15A	0,25-0,35	max.0,35	0,30-1,00	0,040	0,040						275		470		22	
	STKM 15C	0,25-0,35	max.0,35	0,30-1,00	0,040	0,040						430		580		12	
	STKM 16A	0,35-0,45	max.0,40	0,40-1,00	0,040	0,040						325		510		20	
	STKM 16C	0,35-0,45	max.0,40	0,40-1,00	0,040	0,040						460		620		12	
	STKM 17A	0,45-0,55	max.0,40	0,40-1,00	0,040	0,040						345		550		20	
	STKM 17C	0,45-0,55	max.0,40	0,40-1,00	0,040	0,040						480		650		10	
	STKM 18A	max.0,18	max.0,55	max.1,50	0,040	0,040						275		440		25	
	STKM 18B	max.0,18	max.0,55	max.1,50	0,040	0,040						315		490		23	
	STKM 18C	max.0,18	max.0,55	max.1,50	0,040	0,040						380		510		15	
	STKM 19A	max.0,25	max.0,55	max.1,50	0,040	0,040						315		490		23	
STKM 19C	max.0,25	max.0,55	max.1,50	0,040	0,040						410		550		15		
STKM 20A	max.0,25	max.0,55	max.1,60	0,040	0,040					V max.0,15	390		540		23		
G3454	STPG 370	max.0,25	max.0,35	0,30-0,90	0,040	0,040						215		370		30	
	STPG 410	max.0,30	max.0,35	0,30-1,00	0,040	0,040						245		410		25	
G3455	STS 370	max.0,25	0,10-0,35	0,30-1,10	0,035	0,035						215		370		30	
	STS 410	max.0,30	0,10-0,35	0,30-1,40	0,035	0,035						245		410		25	
	STS 480	max.0,33	0,10-0,35	0,30-1,50	0,035	0,035						275		480		25	
G3456	STPT 370	max. 0,25	0,10-0,35	0,30-0,90	0,035	0,035						215		370		30	
	STPT 410	max. 0,30	0,10-0,35	0,30-1,00	0,035	0,035						245		410		25	
	STPT 480	max. 0,33	0,10-0,35	0,30-1,00	0,035	0,035						275		480		25	
<b>PN-H</b>																	
84018	18G2A	max.0,20	0,20-0,55	1,0-1,6	0,040	0,040	max.0,30	max.0,30				365		510		22	
	18G2	max.0,22	0,20-0,55	1,0-1,6	0,050	0,040											
84019	10	0,07-0,14	0,15-0,40	0,35-0,65	0,040	0,040	max.0,30	max.0,30	max.0,10	max.0,30		195		345		25	
	20	0,17-0,24	0,15-0,40	0,35-0,65	0,040	0,040	max.0,30	max.0,30	max.0,10	max.0,30		225		440		21	
	35	0,32-0,39	0,10-0,40	0,50-0,80	0,040	0,040	max.0,30	max.0,30	max.0,10	max.0,30		255		540		17	
	45	0,42-0,50	0,10-0,40	0,50-0,80	0,040	0,040	max.0,30	max.0,30	max.0,10	max.0,30		295		640		14	
	55	0,52-0,60	0,10-0,40	0,60-0,90	0,045	0,045	max. 0,40	max. 0,40	max. 0,10	max. 0,30		380		680		11	
84023/07	R35	0,07-0,16	0,12-0,35	0,40-0,75	0,040	0,040	max.0,30	max.0,30	max.0,10	max.0,30		215		360		24	
	R45	0,16-0,22	0,12-0,35	0,60-1,2	0,040	0,040	max.0,30	max.0,30	max.0,10	max.0,30		255		430		22	
	R55	0,32-0,40	0,20-0,35	0,60-0,85	0,045	0,045	max.0,30	max.0,30	max.0,10	max.0,30		295		540		17	

**Dimensions and weight of cold drawn precision seamless tubes according to STN, ČSN, BS, GOST, EN, DIN, UNI, NF standards (dimensions are valid also for other standards)**

**Table 23**

Outside diameter [mm]	Wall thickness [mm]																		
	0,5	1	1,5	2	2,5	3	3,5	4	4,5	5	5,5	6	7	8	9	10	11.0	12.0	13.0
	Tube weight [kg/m]																		
4	0,043	0,074																	
5	0,055	0,099																	
6	0,068	0,123	0,166	0,197															
7	0,08	0,148	0,203	0,247															
8	0,093	0,173	0,24	0,296	0,339	0,37													
9	0,105	0,197	0,277	0,345	0,401	0,444													
10	0,117	0,222	0,314	0,395	0,462	0,518	0,561												
12	0,142	0,271	0,388	0,493	0,586	0,666	0,734	0,789											
14	0,166	0,321	0,462	0,592	0,709	0,814	0,906	0,986	1,054	1,11									
15	0,179	0,345	0,499	0,641	0,771	0,888	0,993	1,085	1,165	1,233									
16	0,191	0,37	0,536	0,691	0,832	0,962	1,079	1,184	1,276	1,356									
18	0,216	0,419	0,61	0,789	0,956	1,11	1,252	1,381	1,498	1,603									
20	0,24	0,469	0,684	0,888	1,079	1,258	1,424	1,578	1,72	1,85	1,967	2,071							
22	0,265	0,518	0,758	0,986	1,202	1,406	1,597	1,777	1,942	2,096	2,24	2,367							
24	0,29	0,567	0,832	1,085	1,326	1,554	1,769	1,973	2,164	2,343	2,509	2,663							
25	0,302	0,592	0,869	1,134	1,387	1,628	1,856	2,072	2,275	2,446	2,645	2,811							
26	0,314	0,617	0,906	1,184	1,449	1,702	1,942	2,17	2,386	2,59	2,78	2,959							
28		0,666	0,98	1,282	1,572	1,85	2,115	2,368	2,608	2,836	3,052	3,255							
30		0,715	1,054	1,381	1,695	1,988	2,287	2,565	2,83	3,083	3,323	3,551	3,97						
32		0,764	1,128	1,48	1,819	2,146	2,46	2,762	3,052	3,329	3,594	3,847	4,316	4,735					
35		0,838	1,239	1,628	2,004	2,367	2,719	3,058	3,385	3,699	4,001	4,291	4,834	5,327					
36		0,863	1,276	1,677	2,065	2,441	2,805	3,157	3,496	3,822	4,137	4,439	5,006	5,524					
38		0,912	1,35	1,766	2,189	2,589	2,978	3,354	3,718	4,069	4,408	4,735	5,352	5,919					
40		0,962	1,424	1,874	2,312	2,737	3,15	3,551	3,94	4,316	4,68	5,031	5,697	6,313	6,88	7,398	7,867		
42		1,011	1,498	1,973	2,435	2,885	3,323	3,749	4,162	4,562	4,951	5,327	6,042	6,708	7,324	7,892	8,41		
45		1,085	1,609	2,12	2,62	3,107	3,582	4,044	4,494	4,932	5,358	5,77	6,56	7,3	7,99	8,631	9,223		
46		1,11	1,646	2,17	2,682	3,181	3,668	4,143	4,605	5,055	5,493	5,919	6,733	7,497	8,212	8,878	9,949		
48		1,159	1,72	2,269	2,805	3,329	3,841	4,34	4,827	5,302	5,764	6,215	7,078	7,892	8,656	9,371	10,04		
50		1,208	1,794	2,368	2,929	3,477	4,014	4,538	5,049	5,549	6,036	6,511	7,423	8,286	9,1	9,864	10,58	11,25	
52			1,868	2,466	3,052	3,625	4,188	4,735	5,271	5,795	6,307	6,807	7,768	8,681	9,544	10,36	11,12	11,84	12,5
55			1,979	2,614	3,237	3,847	4,445	5,031	5,604	6,165	6,714	7,25	8,286	9,273	10,21	11,1	11,94	12,73	13,47
58			2,09	2,762	3,422	4,069	4,704	5,327	5,937	6,535	7,121	7,694	8,804	9,865	10,88	11,84	12,75	13,61	14,43
60			2,164	2,861	3,545	4,217	4,877	5,524	6,159	6,782	7,392	7,99	9,149	10,26	11,32	12,33	13,29	14,21	15,07
62			2,238	2,959	3,668	4,365	5,049	5,721	6,381	7,028	7,663	8,286	9,495	10,65	11,76	12,82	13,84	14,8	15,71
65			2,349	3,107	3,853	4,587	5,308	6,017	6,714	7,398	8,07	8,73	10,01	11,25	12,43	13,56	14,65	15,68	16,67
70			2,534	3,354	4,162	4,957	5,74	6,511	7,269	8,015	8,749	9,47	10,88	12,23	13,54	14,8	16,01	17,16	18,27
75			2,719	3,601	4,47	5,327	6,172	7,004	7,824	8,632	9,427	10,21	11,74	13,22	14,65	16,03	17,36	18,64	19,88
80			2,904	3,874	4,778	5,697	6,603	7,497	8,379	9,248	10,11	10,95	12,6	14,21	15,76	17,26	18,72	20,12	21,48
85			3,089	4,094	5,086	6,067	7,035	7,99	8,934	9,865	10,78	11,69	13,47	15,19	16,87	18,5	20,07	21,6	23,08
90			3,274	4,34	5,395	6,437	7,466	8,484	9,489	10,48	11,46	12,43	14,33	16,18	17,98	19,73	21,43	23,08	24,69
95				4,587	5,703	6,807	7,898	8,977	10,04	11,1	12,14	13,17	15,19	17,16	19,09	20,96	22,79	24,56	26,29
100				4,834	6,011	7,176	8,329	9,47	10,6	11,71	12,82	13,91	16,06	18,15	20,2	22,2	24,14	26,04	27,89
110				5,327	6,628	7,916	9,193	10,46	11,71	12,95	14,17	15,39	17,78	20,12	22,42	24,66	26,86	29	31,1
120				5,82	7,244	8,656	10,06	11,44	12,82	14,18	15,53	16,87	19,51	22,1	24,64	27,13	29,57	31,96	34,3
125						9,026	10,49	11,94	13,37	14,8	16,21	17,61	20,37	23,08	25,75	28,36	30,93	33,44	35,91

Exact value of tolerances depends on:

- the method of ordering of precision tubes (Dxd, DxT, dxT),
- tube delivery condition (drawn hard or heat treated),
- optional tolerance requirements.

Specific figures are given in appropriate standards (generally D < ±0,5 %, T = ±10 %).

**Allowed weight tolerances according to ASTM A450 and ASTM A1016 standards Table 24**

Seamless hot finished	Seamless cold finished	
	D ≤ 1 1/2" (38,1 mm)	D > 1 1/2" (38,1 mm)
0 +16 %	0 +12 %	0 +13 %



**Dimensions and tolerances of drawn precisious seamless steel tubes according to EN, DIN, UNI, NFA, PN-H standards**

**Table 25**

D [mm]	Tolerance	Wall thickness [mm]																							
		0,5	0,8	1	1,2	1,5	1,8	2	2,2	2,5	2,8	3	3,5	4	4,5	5	5,5	6	7	8	9	10	12	13	
		Inside diameter and tolerances																							
4		3±0,15	2,4±0,15	2±0,15	1,6±0,15																				
5		4±0,15	3,4±0,15	3±0,15	2,6±0,15																				
6		5±0,15	4,4±0,15	4±0,15	3,6±0,15	3±0,15	2,4±0,15	2±0,15																	
7		6±0,15	5,4±0,15	5±0,15	4,6±0,15	4±0,15	3,4±0,15	3±0,15																	
8		7±0,15	6,4±0,15	6±0,15	5,6±0,15	5±0,15	4,4±0,15	4±0,15	3,6±0,15	3±0,25															
9		8±0,15	7,4±0,15	7±0,15	6,6±0,15	6±0,15	5,4±0,15	5±0,15	4,6±0,15	4±0,25	3,4±0,25														
10		9±0,15	8,4±0,15	8±0,15	7,6±0,15	7±0,15	6,4±0,15	6±0,15	5,6±0,15	5±0,15	4,4±0,25	4±0,25													
12		11±0,15	10,4±0,15	10±0,15	9,6±0,15	9±0,15	8,4±0,15	8±0,15	7,6±0,15	7±0,15	6,4±0,15	6±0,25	5±0,25	4±0,25											
14		13±0,08	12,4±0,08	12±0,08	11,6±0,15	11±0,15	10,40±0,15	10±0,15	9,6±0,15	9±0,15	8,4±0,15	8±0,15	7±0,15	6±0,25	5±0,25										
15	±0,08	14±0,08	13,4±0,08	13±0,08	12,6±0,08	12±0,15	11,4±0,15	11±0,15	1,60±0,15	10±0,15	9,4±0,15	9±0,15	8±0,15	7±0,15	6±0,25	5±0,25									
16		15±0,08	14,4±0,08	14±0,08	13,6±0,08	13±0,8	12,4±0,15	12±0,15	11,6±0,15	11±0,15	10,4±0,15	10±0,15	9±0,15	8±0,15	7±0,15	6±0,25									
18		17±0,08	16,4±0,08	16±0,08	15,6±0,08	15±0,8	14,4±0,08	14±0,08	13,6±0,15	13±0,15	12,4±0,15	12±0,15	11±0,15	10±0,15	9±0,15	7±0,25									
20		19±0,08	18,4±0,08	18±0,08	17,6±0,08	17±0,08	16,4±0,08	16±0,08	15,6±0,15	15±0,15	14,4±0,15	14±0,15	13±0,15	12±0,15	11±0,15	10±0,15	9±0,15	8±0,25							
22		21±0,08	20,4±0,08	20±0,08	19,6±0,08	19±0,08	18,4±0,08	18±0,08	17,6±0,08	17±0,15	16,4±0,15	16±0,15	15±0,15	14±0,15	13±0,075	12±0,15	11±0,15	10±0,15							
25			23,4±0,08	23±0,08	22,6±0,08	22±0,08	21,4±0,08	21±0,08	20,6±0,08	20±0,08	19,4±0,15	19±0,15	18±0,15	17±0,15	16±0,15	15±0,15	14±0,15	13±0,15							
26			24,4±0,08	24±0,08	23,6±0,08	23±0,08	22,4±0,08	22±0,08	21,6±0,08	21±0,08	20,4±0,15	20±0,15	19±0,15	18±0,15	17±0,15	16±0,15	15±0,15	14±0,15							
28			26,4±0,08	26±0,08	25,6±0,08	25±0,08	24,4±0,08	24±0,08	23,6±0,08	23±0,08	22,4±0,08	22±0,15	21±0,15	20±0,15	19±0,15	18±0,15	17±0,15	16±0,15							
30			28,4±0,08	28±0,08	27,6±0,08	27±0,08	26,4±0,08	26±0,08	25,6±0,08	25±0,08	24,4±0,08	24±0,15	23±0,15	22±0,15	21±0,15	20±0,15	19±0,15	18±0,15	16±0,15						
32			30,4±0,15	30±0,15	29,6±0,15	29±0,15	28,4±0,15	28±0,15	27,6±0,15	27±0,15	26,4±0,15	26±0,15	25±0,15	24±0,15	23±0,15	22±0,15	21±0,15	20±0,15	18±0,15	16±0,15					
35	±0,15		33,4±0,15	33±0,15	32,6±0,15	32±0,15	31,4±0,15	31±0,15	30,6±0,15	30±0,15	29,4±0,15	29±0,15	28±0,15	27±0,15	26±0,15	25±0,15	24±0,15	23±0,15	21±0,15	19±0,15					
38			36,4±0,15	36±0,15	35,6±0,15	35±0,15	34,4±0,15	34±0,15	33,6±0,15	33±0,15	32,4±0,15	32±0,15	31±0,15	30±0,15	29±0,15	28±0,15	27±0,15	26±0,15	24±0,15	22±0,15					
40			38,4±0,15	38±0,15	37,6±0,15	37±0,15	36,4±0,15	36±0,15	35,6±0,15	35±0,15	34,4±0,15	34±0,15	33±0,15	32±0,15	31±0,15	30±0,15	29±0,15	28±0,15	26±0,15	24±0,15	22±0,15	20±0,15			
42				42±0,20	39,6±0,20	39±0,20	38,4±0,20	38±0,20	37,6±0,20	37±0,20	36,4±0,20	36±0,20	35±0,20	34±0,20	33±0,20	32±0,20	31±0,20	30±0,20	28±0,20	26±0,20	24±0,20	22±0,20			
45	±0,20			43±0,20	42,6±0,20	42±0,20	41,4±0,20	41±0,20	40,6±0,20	40±0,20	39,4±0,20	39±0,20	38±0,20	37±0,20	36±0,20	35±0,20	34±0,20	33±0,20	31±0,20	29±0,20	27±0,20	25±0,20			
48				46±0,20	45,6±0,20	45±0,20	44,4±0,20	44±0,20	43,6±0,20	43±0,20	42,4±0,20	42±0,20	41±0,20	40±0,20	39±0,20	38±0,20	37±0,20	36±0,20	34±0,20	32±0,20	30±0,20	28±0,20			
50				48±0,20	47,6±0,20	47±0,20	46,4±0,20	46±0,20	45,6±0,20	45±0,20	44,4±0,20	44±0,20	43±0,20	42±0,20	41±0,20	40±0,20	39±0,20	38±0,20	36±0,20	34±0,20	32±0,20	30±0,20			
55	±0,25				52,6±0,25	52±0,25	51,4±0,25	51±0,25	50,6±0,25	50±0,25	49,4±0,25	49±0,25	48±0,25	47±0,25	46±0,25	45±0,25	44±0,25	43±0,25	41±0,25	39±0,25	37±0,25	35±0,25	31±0,25	29±0,25	
60					57,6±0,25	57±0,25	56,4±0,25	56±0,25	55,6±0,25	55±0,25	54,4±0,25	54±0,25	53±0,25	52±0,25	51±0,25	50±0,25	49±0,25	48±0,25	46±0,25	44±0,25	42±0,25	40±0,25	36±0,25	34±0,25	
65	±0,30				62,6±0,30	62±0,30	61,4±0,30	61±0,30	60,6±0,30	60±0,30	59,4±0,30	59±0,30	58±0,30	57±0,30	56±0,30	55±0,30	54±0,30	53±0,30	51±0,30	49±0,30	47±0,30	45±0,30	41±0,30	39±0,30	
70					67,6±0,30	67±0,30	66,4±0,30	66±0,30	65,6±0,30	65±0,30	64,4±0,30	64±0,30	63±0,30	62±0,30	61±0,30	60±0,30	59±0,30	58±0,30	56±0,30	54±0,30	52±0,30	50±0,30	46±0,30	44±0,30	
75	±0,35				72±0,35	71,4±0,35	71±0,35	70,6±0,35	70±0,35	69,4±0,35	69±0,35	68±0,35	67±0,35	66±0,35	65±0,35	64±0,35	63±0,35	61±0,35	59±0,35	57±0,35	55±0,35	51±0,35	49±0,35		
80					77±0,35	76,4±0,35	76±0,35	75,6±0,35	75±0,35	74,4±0,35	74±0,35	73±0,35	72±0,35	71±0,35	70±0,35	69±0,35	68±0,35	66±0,35	64±0,35	62±0,35	60±0,35	56±0,35	54±0,35		
85	±0,40				82±0,40	81,4±0,40	81±0,40	80,6±0,40	80±0,40	79,4±0,40	79±0,40	78±0,40	77±0,40	76±0,40	75±0,40	74±0,40	73±0,40	71±0,40	69±0,40	67±0,40	65±0,40	61±0,40	59±0,40		
90					87±0,40	86,4±0,40	86±0,40	85,6±0,40	85±0,40	84,4±0,40	84±0,40	83±0,40	82±0,40	81±0,40	80±0,40	79±0,40	78±0,40	76±0,40	74±0,40	72±0,40	70±0,40	66±0,40	64±0,40		
95	±0,45								91±0,45	90,6±0,45	90±0,45	89,4±0,45	89±0,45	88±0,45	87±0,45	86±0,45	85±0,45	84±0,45	83±0,45	81±0,45	79±0,45	77±0,45	75±0,45	71±0,45	69±0,45
100									96±0,46	95,6±0,45	95±0,45	94,4±0,45	94±0,45	93±0,45	92±0,45	91±0,45	90±0,45	89±0,45	88±0,45	86±0,45	84±0,45	82±0,45	80±0,45	76±0,45	74±0,45
110	±0,50								106±0,50	105,6±0,50	105±0,50	104,4±0,50	104±0,50	103±0,50	102±0,50	101±0,50	100±0,50	99±0,50	98±0,50	96±0,50	94±0,50	92±0,50	90±0,50	86±0,50	84±0,50
120									116±0,50	115,6±0,50	115±0,50	114,4±0,50	114±0,50	113±0,50	112±0,50	111±0,50	110±0,50	109±0,50	108±0,50	106±0,50	104±0,50	102±0,50	100±0,50	96±0,50	94±0,50
0,025 < T/D											0,025 < T/D < 0,05							0,005 < T/D							

Other dimensions (up to diameter 162) and tolerances upon agreement.

Tolerances D are valid for conditions BK and BKW according to DIN standards and for conditions +C a +LC according to EN standards. At heat treated tubes (conditions NBK, GBK, BKS according to DIN standards and conditions +N, +A, +SR according to EN standards) can be tolerances enlarged, as is shown in the table on page 70.

This is valid also in other standards.

D [mm]	Tolerance	Wall thickness [mm]																		
		0,5	1	1,5	2	2,5	3	3,5	4	4,5	5	5,5	6	7	8	9	10	11	12	13
Inside diameter and tolerances																				
4		3 ±0,12	2 ±0,12																	
5		4 ±0,12	3 ±0,12																	
6		5 ±0,12	4 ±0,10	3 ±0,12	2 ±0,12															
7		6 ±0,12	5 ±0,10	4 ±0,12	3 ±0,12															
8		7 ±0,10	6 ±0,10	5 ±0,10	4 ±0,12	3 ±0,15	2 ±0,15													
9		8 ±0,10	7 ±0,10	6 ±0,10	5 ±0,12	4 ±0,15	3 ±0,15													
10		9 ±0,08	8 ±0,07	7 ±0,08	6 ±0,12	5 ±0,15	4 ±0,15	3 ±0,15												
12	±0,05	11 ±0,08	10 ±0,07	9 ±0,08	8 ±0,10	7 ±0,15	6 ±0,15	5 ±0,15	4 ±0,20											
14		13 ±0,08	12 ±0,07	11 ±0,07	10 ±0,10	9 ±0,12	8 ±0,15	7 ±0,15	6 ±0,20	5 ±0,20	4 ±0,20									
15		14 ±0,08	13 ±0,07	12 ±0,07	11 ±0,10	10 ±0,12	9 ±0,15	8 ±0,15	7 ±0,15	6 ±0,20	5 ±0,20									
16		15 ±0,08	14 ±0,07	13 ±0,07	12 ±0,10	11 ±0,12	10 ±0,15	9 ±0,15	8 ±0,15	7 ±0,15	6 ±0,20									
18		17 ±0,08	16 ±0,06	15 ±0,05	14 ±0,05	13 ±0,05	12 ±0,05	11 ±0,05	10 ±0,05	9 ±0,15	8 ±0,15									
20		19 ±0,08	18 ±0,06	17 ±0,05	16 ±0,05	15 ±0,05	14 ±0,05	13 ±0,05	12 ±0,05	11 ±0,15	10 ±0,15	9 ±0,15	8 ±0,15							
22		21 ±0,08	20 ±0,06	19 ±0,05	18 ±0,05	17 ±0,05	16 ±0,05	15 ±0,05	14 ±0,05	13 ±0,10	12 ±0,15	11 ±0,15	10 ±0,15							
25		24 ±0,08	23 ±0,08	22 ±0,08	21 ±0,08	20 ±0,08	19 ±0,08	18 ±0,08	17 ±0,06	16 ±0,06	15 ±0,06	14 ±0,06	13 ±0,06							
26		25 ±0,08	24 ±0,08	23 ±0,08	22 ±0,08	21 ±0,08	20 ±0,08	19 ±0,08	18 ±0,06	17 ±0,06	16 ±0,06	15 ±0,06	14 ±0,06							
28	±0,07		26 ±0,08	25 ±0,08	24 ±0,08	23 ±0,08	22 ±0,08	21 ±0,08	20 ±0,08	19 ±0,08	18 ±0,06	17 ±0,06	16 ±0,06							
30			28 ±0,08	27 ±0,08	26 ±0,08	25 ±0,08	24 ±0,08	23 ±0,08	22 ±0,08	21 ±0,08	20 ±0,08	19 ±0,06	18 ±0,06	16 ±0,06						
32	±0,10		30 ±0,12	29 ±0,12	28 ±0,12	27 ±0,10	26 ±0,10	25 ±0,10	24 ±0,10	23 ±0,08	22 ±0,08	21 ±0,08	20 ±0,08	18 ±0,08	16 ±0,08					
35			33 ±0,12	32 ±0,12	31 ±0,12	30 ±0,10	29 ±0,10	28 ±0,10	27 ±0,10	26 ±0,08	25 ±0,08	24 ±0,08	23 ±0,08	21 ±0,08	19 ±0,08					
38	±0,12		36 ±0,14	35 ±0,14	34 ±0,14	33 ±0,10	32 ±0,10	31 ±0,10	30 ±0,10	29 ±0,10	28 ±0,08	27 ±0,08	26 ±0,08	24 ±0,08	22 ±0,08					
40			38 ±0,14	37 ±0,14	36 ±0,14	35 ±0,10	34 ±0,10	33 ±0,10	32 ±0,10	31 ±0,10	30 ±0,08	29 ±0,08	28 ±0,08	26 ±0,08	24 ±0,08	22 ±0,10	20 ±0,10	18 ±0,10		
42	±0,15		40 ±0,18	39 ±0,18	38 ±0,18	37 ±0,18	36 ±0,15	35 ±0,15	34 ±0,15	33 ±0,15	32 ±0,10	31 ±0,10	30 ±0,10	28 ±0,10	26 ±0,10	24 ±0,10	22 ±0,10	20 ±0,10		
45			43 ±0,18	42 ±0,18	41 ±0,18	40 ±0,18	39 ±0,15	38 ±0,15	37 ±0,15	36 ±0,15	35 ±0,10	34 ±0,10	33 ±0,10	31 ±0,10	29 ±0,10	27 ±0,10	25 ±0,10	23 ±0,10		
48			46 ±0,18	45 ±0,18	44 ±0,18	43 ±0,18	42 ±0,15	41 ±0,15	40 ±0,15	39 ±0,15	38 ±0,10	37 ±0,10	36 ±0,10	34 ±0,10	32 ±0,10	30 ±0,10	28 ±0,10	26 ±0,10		
50			48 ±0,18	47 ±0,18	46 ±0,18	45 ±0,18	44 ±0,15	43 ±0,15	42 ±0,15	41 ±0,15	40 ±0,12	39 ±0,10	38 ±0,10	36 ±0,10	34 ±0,10	32 ±0,10	30 ±0,10	28 ±0,15	26 ±0,15	
55	±0,18			52 ±0,18	51 ±0,18	50 ±0,18	49 ±0,15	48 ±0,15	47 ±0,15	46 ±0,15	45 ±0,12	44 ±0,10	43 ±0,10	41 ±0,10	39 ±0,10	37 ±0,15	35 ±0,15	33 ±0,15	31 ±0,15	29 ±0,15
60				57 ±0,18	56 ±0,18	55 ±0,18	54 ±0,15	53 ±0,15	52 ±0,15	51 ±0,15	50 ±0,12	49 ±0,10	48 ±0,10	46 ±0,10	44 ±0,10	42 ±0,15	40 ±0,15	38 ±0,15	36 ±0,15	34 ±0,15
65	±0,20			62 ±0,20	61 ±0,20	60 ±0,20	59 ±0,20	58 ±0,20	57 ±0,20	56 ±0,15	55 ±0,15	54 ±0,15	53 ±0,15	51 ±0,15	49 ±0,15	47 ±0,15	45 ±0,15	43 ±0,15	41 ±0,15	39 ±0,15
70				67 ±0,25	66 ±0,25	65 ±0,25	64 ±0,20	63 ±0,20	62 ±0,20	61 ±0,15	60 ±0,15	59 ±0,15	58 ±0,15	56 ±0,15	54 ±0,15	52 ±0,15	50 ±0,15	48 ±0,15	46 ±0,15	44 ±0,15
75	±0,25			72 ±0,30	71 ±0,30	70 ±0,30	69 ±0,25	68 ±0,25	67 ±0,25	66 ±0,20	65 ±0,20	64 ±0,20	63 ±0,20	61 ±0,20	59 ±0,20	57 ±0,20	55 ±0,20	53 ±0,20	51 ±0,20	49 ±0,20
80				77 ±0,30	76 ±0,30	75 ±0,30	74 ±0,25	73 ±0,25	72 ±0,25	71 ±0,20	70 ±0,20	69 ±0,20	68 ±0,20	66 ±0,20	64 ±0,20	62 ±0,20	60 ±0,20	58 ±0,20	56 ±0,20	54 ±0,20
85	±0,30			82 ±0,32	81 ±0,32	80 ±0,32	79 ±0,30	78 ±0,30	77 ±0,30	76 ±0,25	75 ±0,20	74 ±0,20	73 ±0,20	71 ±0,20	69 ±0,20	67 ±0,20	65 ±0,20	63 ±0,20	61 ±0,20	59 ±0,20
90				87 ±0,32	86 ±0,32	85 ±0,32	84 ±0,30	83 ±0,30	82 ±0,30	81 ±0,25	80 ±0,25	79 ±0,25	78 ±0,20	76 ±0,20	74 ±0,20	72 ±0,20	70 ±0,20	68 ±0,20	66 ±0,20	64 ±0,20
95	±0,35				91 ±0,35	90 ±0,35	89 ±0,35	88 ±0,30	87 ±0,30	86 ±0,30	85 ±0,25	84 ±0,25	83 ±0,22	81 ±0,22	79 ±0,20	77 ±0,20	75 ±0,20	73 ±0,20	71 ±0,20	69 ±0,20
100					96 ±0,35	95 ±0,35	94 ±0,35	93 ±0,30	92 ±0,30	91 ±0,30	90 ±0,25	89 ±0,25	88 ±0,22	86 ±0,22	84 ±0,20	82 ±0,20	80 ±0,20	78 ±0,20	76 ±0,20	74 ±0,20
110					106 ±0,40	105 ±0,40	104 ±0,40	103 ±0,35	102 ±0,35	101 ±0,35	100 ±0,30	99 ±0,30	98 ±0,25	96 ±0,25	94 ±0,25	92 ±0,25	90 ±0,25	88 ±0,25	86 ±0,25	84 ±0,25
120	±0,40				116 ±0,40	115 ±0,40	114 ±0,40	113 ±0,35	112 ±0,35	111 ±0,35	110 ±0,30	109 ±0,30	108 ±0,30	106 ±0,25	104 ±0,25	102 ±0,25	100 ±0,25	98 ±0,25	96 ±0,25	94 ±0,25
125							119 ±0,40	118 ±0,35	117 ±0,35	116 ±0,35	115 ±0,30	114 ±0,30	113 ±0,30	111 ±0,30	109 ±0,30	107 ±0,30	105 ±0,30	103 ±0,30	101 ±0,30	99 ±0,30

Tolerances for heat threaded tubes - inside diameter  
 - dimensions indicated in   tolerance limits to be multiplied by 1,5  
 - dimensions indicated in   tolerance limits to be multiplied by 2

Possible outside diameter tolerances for heat treated precision tubes

Table 27

Ratio T/D	Tolerances are multiplied by:
> 0,05	1
0,05 > T/D > 0,025	1,5
< 0,025	2

**Dimensions and weight of cold drawn steel tubes according to**

**Table 28**

A/SA-999 ---A/SA-333; (A/SA 335) average T (A/SA-1016 -- A/SA-213; upon agreement average T)

BWG - Birmingham Wire Gauge

Weights are valid for nominal wall thickness

Wall thickness			Outside diameter																									
BWG		inch	1/4	5/16	3/8	1/2	5/8	3/4	7/8	1	1 1/4	1 1/2	1 3/4	2	2 1/8	2 1/4	2 1/2	2 3/4	3	3 1/4	3 1/2	3 3/4	4	4 1/4	4 1/2	4 3/4		
Gauge	inch	mm	6,35	7,94	9,53	12,70	15,88	19,05	22,23	25,40	31,75	38,10	44,45	50,80	54,0	57,15	63,50	69,85	76,20	82,55	88,90	95,25	101,60	107,95	114,30	120,65		
25	0,51	kg/m	0,07	0,09	0,11	0,15	0,19	0,23	0,27	0,31																		
	0,020	lbs/ft	0,05	0,06	0,08	0,10	0,13	0,16	0,18	0,21																		
20	0,89	kg/m	0,12	0,15	0,19	0,26	0,33	0,40	0,47	0,54	0,68	0,82																
	0,035	lbs/ft	0,08	0,10	0,13	0,17	0,22	0,27	0,31	0,36	0,45	0,55																
18	1,24	kg/m	0,16	0,21	0,25	0,35	0,45	0,55	0,64	0,74	0,94	1,13	1,33	1,52														
	0,049	lbs/ft	0,11	0,14	0,17	0,24	0,30	0,37	0,43	0,50	0,63	0,76	0,89	1,02														
16	1,65	kg/m	0,19	0,26	0,32	0,45	0,58	0,71	0,84	0,97	1,23	1,48	1,74	2,00	2,13	2,26	2,52	2,78	3,04	3,29	3,55							
	0,065	lbs/ft	0,13	0,17	0,22	0,30	0,39	0,48	0,56	0,65	0,82	1,00	1,17	1,34	1,43	1,52	1,69	1,86	2,04	2,21	2,38							
14	2,11	kg/m		0,30	0,39	0,55	0,72	0,88	1,05	1,21	1,54	1,87	2,20	2,53	2,70	2,86	3,19	3,52	3,85	4,18	4,51	4,84	5,17	5,50	5,83	6,16		
	0,083	lbs/ft		0,20	0,26	0,37	0,48	0,59	0,70	0,81	1,03	1,26	1,48	1,70	1,81	1,92	2,14	2,36	2,59	2,81	3,03	3,25	3,47	3,69	3,92	4,14		
13	2,41	kg/m		0,33	0,42	0,61	0,80	0,99	1,18	1,37	1,75	2,12	2,50	2,88	3,07	3,26	3,64	4,01	4,39	4,77	5,15	5,52	5,90	6,28	6,66	7,04		
	0,095	lbs/ft		0,22	0,28	0,41	0,54	0,66	0,79	0,92	1,17	1,43	1,68	1,93	2,06	2,19	2,44	2,69	2,95	3,20	3,46	3,71	3,96	4,22	4,47	4,72		
12	2,77	kg/m		0,35	0,46	0,68	0,90	1,11	1,33	1,55	1,98	2,41	2,85	3,28	3,50	3,71	4,15	4,58	5,02	5,45	5,88	6,32	6,75	7,19	7,62	8,05		
	0,109	lbs/ft		0,24	0,31	0,46	0,60	0,75	0,89	1,04	1,33	1,62	1,91	2,20	2,35	2,49	2,78	3,07	3,37	3,66	3,95	4,24	4,53	4,82	5,11	5,40		
11	3,05	kg/m				0,73	0,96	1,20	1,44	1,68	2,16	2,64	3,11	3,59	3,83	4,07	4,55	5,02	5,50	5,98	6,46	6,94	7,41	7,89	8,37	8,85		
	0,120	lbs/ft				0,49	0,65	0,81	0,97	1,13	1,45	1,77	2,09	2,41	2,57	2,73	3,05	3,37	3,69	4,01	4,33	4,65	4,97	5,29	5,61	5,93		
10	3,40	kg/m				0,78	1,05	1,31	1,58	1,84	2,38	2,91	3,44	3,97	4,24	4,51	5,04	5,57	6,10	6,64	7,17	7,70	8,23	8,77	9,30	9,83		
	0,134	lbs/ft				0,52	0,70	0,88	1,06	1,24	1,60	1,96	2,31	2,67	2,85	3,03	3,39	3,74	4,10	4,46	4,82	5,18	5,53	5,89	6,25	6,61		
9	3,76	kg/m				0,83	1,12	1,42	1,71	2,01	2,60	3,18	3,77	4,36	4,66	4,95	5,54	6,13	6,72	7,31	7,89	8,48	9,07	9,66	10,25	10,84		
	0,148	lbs/ft				0,56	0,75	0,95	1,15	1,35	1,74	2,14	2,53	2,93	3,13	3,32	3,72	4,11	4,51	4,90	5,30	5,69	6,09	6,48	6,88	7,28		
8	4,19	kg/m				1,21	1,54	1,86	2,19	2,85	3,50	4,16	4,82	5,14	5,47	6,13	6,78	7,44	8,10	8,75	9,41	10,07	10,72	11,38	12,03			
	0,165	lbs/ft				0,81	1,03	1,25	1,47	1,91	2,35	2,79	3,23	3,45	3,67	4,12	4,56	5,00	5,44	5,88	6,32	6,76	7,20	7,64	8,08			
7	4,57	kg/m				1,27	1,63	1,99	2,35	3,06	3,78	4,49	5,21	5,57	5,93	6,64	7,36	8,07	8,79	9,50	10,22	10,94	11,65	12,37	13,08			
	0,180	lbs/ft				0,86	1,10	1,34	1,58	2,06	2,54	3,02	3,50	3,74	3,98	4,46	4,94	5,42	5,90	6,38	6,86	7,34	7,83	8,31	8,79			
6	5,16	kg/m							2,17	2,58	3,38	4,19	5,00	5,81	6,21	6,62	7,42	8,23	9,04	9,85	10,66	11,46	12,27	13,08	13,89	14,70		
	0,203	lbs/ft							1,46	1,73	2,27	2,81	3,35	3,90	4,17	4,44	4,98	5,52	6,06	6,61	7,15	7,69	8,23	8,78	9,32	9,86		
5	5,59	kg/m							2,29	2,73	3,61	4,48	5,36	6,23	6,67	7,11	7,98	8,86	9,73	10,61	11,48	12,36	13,24	14,11	14,99	15,86		
	0,220	lbs/ft							1,54	1,83	2,42	3,01	3,60	4,18	4,48	4,77	5,36	5,95	6,53	7,12	7,71	8,30	8,88	9,47	10,06	10,65		
4	6,05	kg/m								3,83	4,78	5,73	6,68	7,15	7,62	8,57	9,52	10,47	11,41	12,36	13,31	14,26	15,20	16,15	17,10			
	0,238	lbs/ft								2,57	3,21	3,84	4,48	4,80	5,11	5,75	6,39	7,02	7,66	8,29	8,93	9,56	10,20	10,83	11,47			
3	6,58	kg/m									5,11	6,15	7,18	7,69	8,21	9,24	10,27	11,30	12,33	13,36	14,39	15,42	16,45	17,48	18,51			
	0,259	lbs/ft									3,43	4,12	4,82	5,16	5,51	6,20	6,89	7,58	8,27	8,97	9,66	10,35	11,04	11,73	12,42			
2	7,21	kg/m										5,49	6,62	7,75	8,32	8,88	10,01	11,14	12,27	13,40	14,53	15,65	16,78	17,91	19,04			
	0,284	lbs/ft										3,69	4,45	5,21	5,58	5,96	6,72	7,48	8,24	9,00	9,76	10,51	11,27	12,03	12,79			
1	7,62	kg/m											6,92	8,11	8,71	9,31	10,50	11,69	12,89	14,08	15,27	16,47	17,66	18,85	20,05			
	0,300	lbs/ft											4,65	5,45	5,85	6,25	7,05	7,85	8,65	9,45	10,25	11,06	11,86	12,66	13,46			
0	8,64	kg/m												7,63	8,98	9,66	10,33	11,68	13,04	14,39	15,74	17,09	18,45	19,80	21,15			
	0,340	lbs/ft												5,12	6,03	6,48	6,94	7,84	8,75	9,66	10,57	11,48	12,38	13,29	14,20			
2/0	9,65	kg/m													8,28	9,79	10,55	11,31	12,82	14,33	15,84	17,35	18,86	20,38	21,89			
	0,380	lbs/ft													5,56	6,58	7,08	7,59	8,60	9,62	10,63	11,65	12,66	13,68	14,69			
3/0	10,80	kg/m														8,96	10,65	11,50	12,34	14,03	15,72	17,41	19,10	20,79	22,48			
	0,425	lbs/ft														6,01	7,15	7,72	8,28	9,42	10,55	11,69	12,82	13,96	15,09			
4/0	11,53	kg/m															12,97	14,78	16,59	18,39	20,20	22,00	23,81	25,62	27,42			
	0,454	lbs/ft															8,71	9,92	11,13	12,35	13,56	14,77	15,98	17,20	18,41			

**Allowed outside diameter tolerances according to ASTM A450/A450M and ASTM A1016/A1016M standards Table 29**

Outside diameter			
Hot formed	do 4" (101,6 mm)	-1/32 (0,8 mm)	+1/64 (0,4 mm)
	4"-7 1/2" (101,6-190,5 mm)	-3/64 (1,2 mm)	+1/64 (0,4 mm)
Cold drawn	do 1" (25,4 mm)	-0.004 (0,1 mm)	+0.004 (0,1 mm)
	1"-1 1/2" (25,4-38,1 mm)	-0.006 (0,15 mm)	+0.006 (0,15 mm)
	nad 1 1/2"-2" (38,1-50,8 mm)	-0.008 (0,2 mm)	+0.008 (0,2 mm)
	2"-2 1/2" (50,8-63,5 mm)	-0.010 (0,25 mm)	+0.010 (0,25 mm)
	2 1/2"-3" (63,5-76,2 mm)	-0.012 (0,3 mm)	+0.012 (0,3 mm)
	3"-4" (76,2-101,6 mm)	-0.015 (0,38 mm)	+0.015 (0,38 mm)
	4"-7 1/2" (101,6-190,5 mm)	-0.015 (0,38 mm)	+0.025 (0,64 mm)

**Dimensions and weight of cold drawn steel tubes according to**

**Table 30**

A/SA-450 -- A/SA 179; A/SA-192; A/SA-210; A/SA556 - min T

A/SA-1016 -- A/SA-209; A/SA-213; A/SA-334 - min T (A/SA-999 -- A/SA-335 - upon agreement min T)

BWG - Birmingham Wire Gauge

Weights are valid for nominal wall thickness

Wall thickness			Outside diameter																									
BWG		inch	1/4	5/16	3/8	1/2	5/8	3/4	7/8	1	1 1/4	1 1/2	1 3/4	2	2 1/8	2 1/4	2 1/2	2 3/4	3	3 1/4	3 1/2	3 3/4	4	4 1/4	4 1/2	4 3/4		
Gauge	inch	mm	6,35	7,94	9,53	12,70	15,88	19,05	22,23	25,40	31,75	38,10	44,45	50,80	54,0	57,15	63,50	69,85	76,20	82,55	88,90	95,25	101,60	107,95	114,30	120,65		
25	0,51	kg/m	0,08	0,10	0,12	0,17	0,21	0,25	0,30	0,34																		
	0,020	lbs/ft	0,05	0,07	0,08	0,11	0,14	0,17	0,20	0,23																		
20	0,89	kg/m	0,13	0,17	0,21	0,28	0,36	0,44	0,51	0,59	0,74	0,90	1,05															
	0,035	lbs/ft	0,09	0,11	0,14	0,19	0,24	0,29	0,34	0,40	0,50	0,60	0,70															
18	1,24	kg/m	0,17	0,22	0,28	0,38	0,49	0,60	0,70	0,81	1,03	1,24	1,45	1,67														
	0,049	lbs/ft	0,11	0,15	0,18	0,26	0,33	0,40	0,47	0,54	0,69	0,83	0,98	1,12														
16	1,65	kg/m	0,20	0,27	0,35	0,49	0,63	0,77	0,91	1,06	1,34	1,63	1,91	2,19	2,34	2,48	2,76	3,05	3,33	3,62	3,90							
	0,065	lbs/ft	0,14	0,18	0,23	0,33	0,42	0,52	0,61	0,71	0,90	1,09	1,28	1,47	1,57	1,66	1,85	2,05	2,24	2,43	2,62							
14	2,11	kg/m		0,32	0,41	0,59	0,78	0,96	1,14	1,32	1,68	2,05	2,41	2,77	2,95	3,14	3,50	3,86	4,22	4,59	4,95	5,31	5,68	6,04	6,40	6,77		
	0,083	lbs/ft		0,22	0,28	0,40	0,52	0,64	0,76	0,89	1,13	1,37	1,62	1,86	1,98	2,11	2,35	2,59	2,84	3,08	3,32	3,57	3,81	4,06	4,30	4,54		
13	2,41	kg/m		0,35	0,45	0,66	0,87	1,07	1,28	1,49	1,90	2,32	2,74	3,15	3,36	3,57	3,98	4,40	4,81	5,23	5,65	6,06	6,48	6,89	7,31	7,72		
	0,095	lbs/ft		0,23	0,30	0,44	0,58	0,72	0,86	1,00	1,28	1,56	1,84	2,12	2,26	2,39	2,67	2,95	3,23	3,51	3,79	4,07	4,35	4,63	4,91	5,19		
12	2,77	kg/m		0,37	0,49	0,73	0,96	1,20	1,44	1,68	2,16	2,63	3,11	3,59	3,83	4,07	4,54	5,02	5,50	5,97	6,45	6,93	7,41	7,88	8,36	8,84		
	0,109	lbs/ft		0,25	0,33	0,49	0,65	0,81	0,97	1,13	1,45	1,77	2,09	2,41	2,57	2,73	3,05	3,37	3,69	4,01	4,33	4,65	4,97	5,29	5,61	5,93		
11	3,05	kg/m				0,77	1,04	1,30	1,56	1,82	2,35	2,87	3,40	3,93	4,19	4,45	4,98	5,50	6,03	6,55	7,08	7,60	8,13	8,65	9,18	9,70		
	0,120	lbs/ft				0,52	0,70	0,87	1,05	1,22	1,58	1,93	2,28	2,63	2,81	2,99	3,34	3,69	4,04	4,40	4,75	5,10	5,45	5,81	6,16	6,51		
10	3,40	kg/m				0,83	1,12	1,41	1,70	2,00	2,58	3,17	3,75	4,34	4,63	4,93	5,51	6,10	6,68	7,27	7,85	8,44	9,03	9,61	10,20	10,78		
	0,134	lbs/ft				0,56	0,75	0,95	1,15	1,34	1,74	2,13	2,52	2,92	3,11	3,31	3,70	4,10	4,49	4,88	5,28	5,67	6,07	6,46	6,85	7,25		
9	3,76	kg/m				0,87	1,20	1,52	1,85	2,17	2,82	3,46	4,11	4,76	5,08	5,41	6,06	6,70	7,35	8,00	8,65	9,29	9,94	10,59	11,24	11,88		
	0,148	lbs/ft				0,59	0,80	1,02	1,24	1,46	1,89	2,33	2,76	3,19	3,41	3,63	4,06	4,50	4,93	5,37	5,80	6,24	6,67	7,11	7,54	7,98		
8	4,19	kg/m				1,28	1,64	2,00	2,36	3,08	3,81	4,53	5,25	5,61	5,97	6,69	7,42	8,14	8,86	9,58	10,30	11,02	11,75	12,47	13,19			
	0,165	lbs/ft				0,86	1,10	1,34	1,59	2,07	2,56	3,04	3,53	3,77	4,01	4,49	4,98	5,46	5,95	6,43	6,92	7,40	7,89	8,37	8,86			
7	4,57	kg/m				1,34	1,74	2,13	2,53	3,31	4,10	4,89	5,67	6,07	6,46	7,25	8,04	8,82	9,61	10,40	11,19	11,97	12,76	13,55	14,33			
	0,180	lbs/ft				0,90	1,17	1,43	1,70	2,22	2,75	3,28	3,81	4,08	4,34	4,87	5,40	5,93	6,45	6,98	7,51	8,04	8,57	9,10	9,63			
6	5,16	kg/m								2,32	2,76	3,65	4,54	5,43	6,32	6,76	7,21	8,09	8,98	9,87	10,76	11,65	12,54	13,43	14,32	15,21	16,09	
	0,203	lbs/ft								1,55	1,85	2,45	3,05	3,64	4,24	4,54	4,83	5,43	6,03	6,62	7,22	7,82	8,41	9,01	9,60	10,20	10,80	
5	5,59	kg/m								2,44	2,92	3,88	4,85	5,81	6,77	7,25	7,73	8,70	9,66	10,62	11,59	12,55	13,51	14,47	15,44	16,40	17,36	
	0,220	lbs/ft								1,64	1,96	2,61	3,25	3,90	4,54	4,87	5,19	5,84	6,48	7,13	7,78	8,42	9,07	9,71	10,36	11,01	11,65	
4	6,05	kg/m									4,12	5,16	6,20	7,25	7,77	8,29	9,33	10,37	11,41	12,46	13,50	14,54	15,58	16,62	17,67	18,71		
	0,238	lbs/ft									2,76	3,46	4,16	4,86	5,21	5,56	6,26	6,96	7,66	8,36	9,06	9,75	10,45	11,15	11,85	12,55		
3	6,58	kg/m										5,51	6,64	7,78	8,34	8,91	10,04	11,18	12,31	13,44	14,58	15,71	16,84	17,98	19,11	20,24		
	0,259	lbs/ft										3,70	4,46	5,22	5,60	5,98	6,74	7,50	8,26	9,02	9,78	10,54	11,31	12,07	12,83	13,59		
2	7,21	kg/m											5,90	7,14	8,38	9,01	9,63	10,87	12,11	13,35	14,59	15,84	17,08	18,32	19,56	20,80	22,05	
	0,284	lbs/ft											3,96	4,80	5,63	6,05	6,47	7,30	8,13	8,97	9,80	10,64	11,47	12,31	13,14	13,97	14,81	
1	7,62	kg/m												7,46	8,77	9,42	10,08	11,39	12,71	14,02	15,33	16,64	17,96	19,27	20,58	21,89	23,21	
	0,300	lbs/ft												5,01	5,89	6,33	6,77	7,65	8,53	9,41	10,29	11,17	12,06	12,94	13,82	14,70	15,58	
0	8,64	kg/m													8,19	9,68	10,42	11,16	12,65	14,14	15,63	17,11	18,60	20,09	21,58	23,06	24,55	26,04
	0,340	lbs/ft													5,50	6,50	6,99	7,49	8,49	9,49	10,49	11,49	12,49	13,49	14,49	15,48	16,48	17,48
2/0	9,65	kg/m													8,86	10,52	11,35	12,18	13,85	15,51	17,17	18,83	20,50	22,16	23,82	25,49	27,15	28,81
	0,380	lbs/ft													5,95	7,06	7,62	8,18	9,30	10,41	11,53	12,64	13,76	14,88	15,99	17,11	18,23	19,34
3/0	10,80	kg/m													9,54	11,40	12,33	13,26	15,12	16,98	18,84	20,70	22,56	24,42	26,28	28,14	29,99	31,85
	0,425	lbs/ft													6,40	7,65	8,28	8,90	10,15	11,40	12,65	13,89	15,14	16,39	17,64	18,89	20,14	21,38
4/0	11,53	kg/m																13,91	15,90	17,88	19,87	21,86	23,84	25,83	27,82	29,80	31,79	33,78
	0,454	lbs/ft																9,34	10,67	12,01	13,34	14,67	16,01	17,34	18,67	20,01	21,34	22,67

**Notes:**

1. Weights are valid for average (nominal) wall thickness. See also notes on page 46
2. Other dimensions upon agreement. Wall thickness according BWG and SWG (see table 55 on page 117) within range 25 – 2/0 (BWG) and 25 – 3/0 (SWG).

**Allowed wall thickness tolerances according to ASTM A450/A450M a ASTM A1016 standards**

**Table 31**

Wall thickness				
Hot formed	do 0,095" (2,4 mm)	0,095"–0,15" (2,4–3,8 mm)	0,15"–0,18" (3,8–4,6 mm)	nad 0,18" (4,6 mm)
	0 +40%	0 +35%	0 +33%	0 +28%
Cold drawn	With outside diameter			
	do 1 1/2" (38,1 mm)	0 +20%	above 1 1/2" (38,1 mm)	0 +22%

## Steel tubes for automotive industry

Production programm – see Tables 23–31 at pages 68–72.

### Production process

Precision seamless steel tubes - cold finished

Standards	Steel
EN 10305 Part1	E215, E235, E355 (others upon agreement)
ASTM A519	Table 1 and 2 of Standard
DIN 2391	St 35, St 45, St 52
BS 6323 Part 4	CFS 3, CFS 4, CFS 5, CFS 8
NF A49-310	TU 37-b, TU 52-b, TU 20MV6

Deliveries according to TDC of customer upon agreement.

Steel grades chemical composition and mechanical properties can be found in tables in the chapter of Precision standard steel tubes.

### List of dimensional standards and technical delivery conditions standards

ASTM A519	Seamless carbon and alloy steel mechanical tubing.
DIN 2391	Seamless precision steel tubes.
BS 6323-4	Specification for seamless and welded steel tubes for automobile, mechanical and general engineering purposes. Part 4: Specific requirements for cold finished seamless steel tubes.
NF A49-310	Steel tubes - Seamless precision tubes for mechanical application.

### Lengths

- random 3–9 m
- exact cut lengths
- cutting of tubes (tubes can be also worked by other technologies – see page 86)

### Steel grade

Steel is shown in the table of chemical composition and mechanical properties.

### Delivery conditions (see page 104)

- +C (BK) – cold finished/hard (without heat treatment)
- +LC (BKW) – cold finished/soft
- +SR (BKS) – cold drawn and stress relieve annealed
- +N (NBK) – normalized

### Testing

Tubes are tested according to the production standards. Eddy current test upon request according to EN ISO 10893-1,-2.

### Marking

According to the production standards or, on request, colour stencilling along whole tube length according to customer specification.

### Surface protection

Without protection or oiled.

### Packaging

In round bundles of maximum weight 2 tons each, fastened with steel strips.

### Certified test report

According to EN10204 -2.2, 3.1., 3.2 (See also page 7).

## Injection tubes

Tubes for injection system of Diesel engines are produced upon agreement. (ČSN 42 6718, DIN 73000, ISO 8353-1, steel grades 12015, St 30Al, St 30Si).

## Tubes, galvanized with PVC coating

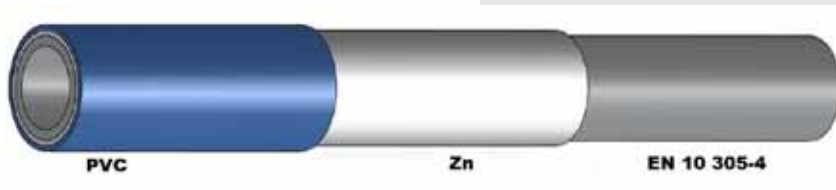

For the plastic coating of the tubes the following assortment range is used:  
Precision seamless steel galvanized HPL pipes (page 79).  
Grades: E 235+N, according to DIN 10 305-1 or 4, other grades are possible by arrangement.

### Dimensions of pipes with PVC coating

Tubes are supplied in the dimension 6.0 x 1.0 mm, other dimensions are possible by arrangement. Lengths are 6 000 mm and are supplied in bundles or in a flat condition.

### Marking tubes with PVC coating

Each meter of a tube is marked as follows, font size 2 mm:  
CUSTOMER - 6 x 1 SEAMLESS CNG ISO 15500 GASTEC approval 122779/1 110R-000130H1

### Packaging of the tubes with PVC coating

Bundles of tubes diameter from 200 to 300 mm, are packed in cardboard boxes and shipped on a pallet, straight tubes are tied in bundles with steel tape, underlined with paper or plastic.

### Testing of tubes with PVC coating

The tubes are eddy current tested according to EN 10246-3 standard.

### Properties of the PVC coating

This is the material free of lead (Pb) and cadmium (Cd), the surface color is white, matt. Operating temperature between -55 and 135 ° C, in case of fire coating is flame-retardant. The protective layer PVC does not corrode and is well resistant to chemicals.

Tubes are designed for gas distribution in CNG-powered cars. Distribution of gas in vehicles with CNG consists of high and low pressure parts. High pressure parts connect the pressure vessel portion in which the gas pressure reaches 22 MPa with filling connection and pressure regulator located in the engine compartment.

## Special tubular sections

Special sections for power transmissions for the agricultural industry are manufactured in various sections (lemon, star, triangular) in accordance with international and European standards.

Special tubes with cylindrical or octagonal outside sections with rifling inside. The inside rifling is produced directly by lamination during the cold drawing. These tubes are manufactured in carbon steel or alloyed steel grades.

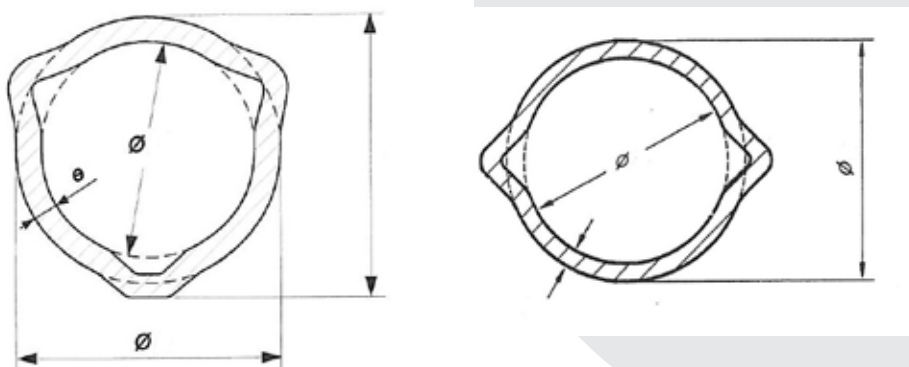



## Tubes for hydraulic and pneumatic cylinders

### Precision tubes for mechanical treatment – HPZ

---

#### Dimensions

Dimensions of HPZ tubes are given in Table 32/Page 76.

#### Tolerances

- outside diameter according to standards DIN 2391-1, EN 10305-1, ČSN/STN 42 6712
- inside diameter – Table 32
- wall thickness  $\pm 7,5\%$
- eccentricity is included in the tolerances of wall thickness

#### Lengths

- random lengths 3–6 m
- fixed lengths max. 6 m

#### Straightness

1 mm/m (1 : 1 000) – measured on outside surface.

#### Tube ends

Plain, upon request ends could be plugged with plastic caps.

#### Steel grade

- 11 523 according to STN, ČSN
- St 52 according to DIN 2391, St 52-3 according to DIN 17100
- E 355 according to EN 10305-1
- 20 Mn V 6 according to EN 10294-1
- another steel upon agreement

#### Delivery condition

BKS (+SR) – cold finished / stress relieve annealed. Other conditions upon agreement.

#### Outside diameter

Smooth after cold drawing (DIN 2391).

#### Testing

- cast analysis
- tensile test
- visual test
- dimensional test
- NDT (eddy current test)
- other tests upon agreement

#### Marking

Colour stencilling along whole tube length:

- producer's logo
- size (D – d)
- steel
- heat No.
- standard number (or according to customer's specification)

#### Surface protection

Tubes are oiled.

#### Packaging

Tubes are packed in round or hexagonal bundles with weight max. 2000 kg, fastened with steel strips.

#### Certified test report

According to EN 10204 - 3.1.

**Dimensions and weight of HPZ tubes for mechanical machining**
**Table 32**

Inside diameter [mm]	Tolerance of inside diameter [mm]	D x T [mm]	Weight [kg/m]
<b>40</b>	-0,20 / -0,40	50 x 5	5,55
		52 x 6	6,80
		55 x 7,5	8,78
		60 x 10	12,33
<b>45</b>		55 x 5	6,16
		57 x 6	7,55
		60 x 7,5	9,71
		65 x 10	13,56
<b>50</b>		60 x 5	6,78
		62 x 6	8,28
		65 x 7,5	10,64
		70 x 10	14,80
<b>55</b>	-0,20 / -0,50	65 x 5	7,40
		67 x 6	9,03
		70 x 7,5	11,56
		75 x 10	16,03
<b>60</b>		70 x 5	8,01
		72 x 6	9,77
		75 x 7,5	12,48
		80 x 10	17,26
<b>63</b>		73 x 5	8,38
		75 x 6	10,21
		78 x 7,5	13,04
		83 x 10	18,00
<b>65</b>	75 x 5	8,64	
	77 x 6	10,51	
	80 x 7,5	13,41	
	85 x 10	18,50	
<b>70</b>	80 x 5	9,25	
	82 x 6	11,25	
	85 x 7,5	14,33	
	90 x 10	19,73	

Inside diameter [mm]	Tolerance of inside diameter [mm]	D x T [mm]	Weight [kg/m]	
<b>75</b>	-0,20 / -0,55	85 x 5	9,86	
		87 x 6	11,99	
		90 x 7,5	15,26	
		95 x 10	20,96	
<b>80</b>		90 x 5	10,48	
		92 x 6	12,72	
		95 x 7,5	16,18	
		100 x 10	22,20	
<b>85</b>		95 x 5	11,10	
		97 x 6	13,46	
		100 x 7,5	17,11	
		105 x 10	23,43	
<b>90</b>	-0,25 / -0,70	100 x 5	11,71	
		102 x 6	14,20	
		105 x 7,5	18,03	
		110 x 10	24,66	
<b>100</b>		110 x 5	12,95	
		112 x 6	15,68	
		115 x 7,5	19,88	
		120 x 10	27,13	
<b>105</b>		-0,25 / -0,75	115 x 5	13,56
			117 x 6	16,42
			120 x 7,5	20,81
			125 x 10	28,36
<b>110</b>	120 x 5		14,18	
	122 x 6		17,16	
	125 x 7,5		21,73	
	130 x 10		29,59	
<b>115</b>	125 x 5		14,80	
	127 x 6		17,90	
	130 x 7,5		22,66	

Upon agreement also tubes with inside diameter 30 mm with T 5 / 6 / 7,5 / 10 mm. Tolerances d according to agreement. The tube weight according to the formula (see page 4).

**Chemical composition and mechanical properties of steel for HPZ tubes  
Delivery condition BKS (+SR)**

Steel	C max %	Mn max %	Si max %	P max %	S max %	Al min %	R <sub>eH</sub> (N/mm <sup>2</sup> )	R <sub>m</sub> (N/mm <sup>2</sup> )	A %
<b>St 52</b>	0,22	1,60	0,55	0,025	0,025	0,020	min. 420	min. 580	min. 10
<b>E 355</b>	0,22	1,60	0,55	0,025	0,025	0,020	min. 450	min. 580	min. 10

Chemical composition and mechanical properties of steel 11 523 and St 52-3 are approximately identical to steel grades in table. Steel 20 Mn V 6 includes V (0,08 - 0,15%), or a part of V is possible to replace with Nb providing that Vmin is 0,05% and contents V + Nb is under 0,15%.

## Tubes for hydraulic and pneumatic cylinders - tubes ready to use

### Precision hydraulic tubes – HP – „ready to use“

---

#### Dimensions

Dimensions and HP tube weight are given in Table 33/78.

#### Tolerances

- outside diameter according to standards DIN 2391-1, EN 10305-1, ČSN/STN 42 6712
- inside diameter – ISO H8, H9 – Table 33
- wall thickness  $\pm 7,5\%$  or  $\pm 10\%$
- eccentricity is included in the tolerances of wall thickness

#### Lengths

- random lengths 2 – 6 m
- fixed lengths max. 6 m

#### Straightness

1 mm / m (1 : 1000) – measured on outside surface.

#### Tube ends

Plain, upon request ends could be plugged with plastic caps.

#### Steel grade

- 11 523 according to STN, ČSN
- St 52 (1.0580) according to DIN 2391, St 52-3 (1.0570) according to DIN 17100
- E 355 (1.0580) according to EN 10305-1
- 20 Mn V 6 according to EN 10294-1 (see pages 21, 114, 115)
- another steel upon agreement

#### Delivery condition

BKS (+SR) - cold finished / stress relieve annealed. Other upon agreement (NBK, +N, BK, +C).

#### Outside surface

Smooth after cold drawing (DIN 2391).

#### Inside surface

Roughness  $R_a \leq 0,4 \mu\text{m}$ ,  $R_z \leq 1,5 \mu\text{m}$ .

#### Testing

- cast analysis
- tensile test
- visual test
- dimensional test
- NDT (eddy current test) according to SEP 1925, EN 10246-1 or another agreed method
- other tests upon agreement

#### Marking

Colour stencilling along whole tube length:

- producer's logo
- size (inside diameter x wall thickness)
- steel
- heat No.
- standard number (or according to customer's specification)
- bundle with label with supplementary informations

#### Surface protection

Tubes are oiled.

#### Packaging

Tubes are packed in round or hexagonal bundles with weight max. 2 000 kg, fastened with steel strips.

#### Certified test report

According to EN 10204 - 3.1.

**Dimensions, tolerances and weight of HP tubes**

**Table 33**

Inside diameter [mm]	Tolerance of inside diameter [mm]		D x T [mm]	Weight [kg/m]	Maximum length [mm]
	H8	H9			
40	0 / +0,039	0 / +0,062	48 x 4	4,34	3 000
			50 x 5	5,55	
			52 x 6	6,81	
			55 x 7,5	8,79	
50	0 / +0,039	0 / +0,062	60 x 5	6,78	4 000
			62 x 6	8,29	
			65 x 7,5	10,64	
60	0 / +0,046	0 / +0,074	70 x 5	8,01	5 000
			72 x 6	9,77	
			75 x 7,5	12,48	
63	0 / +0,046	0 / +0,074	73 x 5	8,38	5 000
			75 x 6	10,21	
			78 x 7,5	13,04	
70	0 / +0,046	0 / +0,074	80 x 5	9,25	6 000
			82 x 6	11,25	
			85 x 7,5	14,33	
			90 x 10	19,73	
80	0 / +0,046	0 / +0,074	90 x 5	10,48	6 000
			92 x 6	12,73	
			95 x 7,5	16,18	
			100 x 10	22,20	
90	0 / +0,054	0 / +0,087	100 x 5	11,71	6 000
			102 x 6	14,21	
			105 x 7,5	18,03	
			110 x 10	24,66	
100	0 / +0,054	0 / +0,087	115 x 7,5	19,88	6 000
			120 x 10	27,13	
110	0 / +0,054	0 / +0,087	125 x 7,5	21,73	6 000
			130 x 10	29,59	

The diameters 80 x 10 mm (17,26 kg/m) and 126 x 8 mm (23,28kg/m) upon agreement

**Chemical composition and mechanical properties of steel for HP tubes**  
**Delivery condition BKS (+SR)**

Steel	C max %	Mn max %	Si max %	P max %	S max %	Al min %	R <sub>eH</sub> (N/mm <sup>2</sup> )	R <sub>m</sub> (N/mm <sup>2</sup> )	A %
<b>St 52</b>	0,22	1,60	0,55	0,025	0,025	0,020	min. 420	min. 580	min. 10
<b>E 355</b>	0,22	1,60	0,55	0,025	0,025	0,020	min. 450	min. 580	min. 10

Chemical composition and mechanical properties of steel 11 523 and St 52-3 are approximately identical to steel grades in table. Steel 20 Mn V 6 includes V (0,08 - 0,15%), or a part of V is possible to replace with Nb providing that V<sub>min</sub> is 0,05% and contents V + Nb is under 0,15%.

## Tubes for hydraulic and pneumatic pressure circuits and galvanized tubes - HPL

Tubes are used in hydraulic and pneumatic power systems.

### A list of standards according to which HPL tubes are delivered:

Standards	Dimensional standards	Dimensions	Technical delivery conditions	Steel grade
<b>STN</b> <b>ČSN</b>	42 6711 42 6712	Table 35/Page 83	42 0260	11 353, 11 523
<b>ASTM</b>	A 822	Tab. 28,30/Page 71,72	A 822/A 450	A 822
<b>DIN</b>	2391-1 2445-2	Table 35/Page 83	2391-2C 2445-2 1630	St 35 St 37.4, St 44.4, St 52.4
<b>BS</b>	7416		7416	CFS 360, CFS 430
<b>UNI</b>	7945		7945	Fe 280, Fe 320, Fe 360, Fe 410, Fe 490
<b>NF A</b>	49-330		49-330	TU 37b, TU 42b, TU 52b
<b>EN</b>	10305-4		10305-4	E 215, E 235, E 355
<b>JIS</b>	JOHS-102		Table 13/Page 50	JOHS-102
<b>PN-H</b>	74245	Table 35/Page 83	74245	10, 20, 18G2A

### List of dimensional standards and technical delivery conditions standards

STN 42 0260	ČSN 42 0260 Cold drawn precision seamless steel tubes from steel class 10 to 16. TDC.
STN 42 6711	ČSN 42 6711 Precision seamless steel tubes. Dimensions.
STN 42 6712	ČSN 42 6712 Precision seamless steel tubes with increased accuracy. Dimensions.
ASTM A450	General requirements for carbon, ferritic alloy and austenitic alloy steel tubes.
ASTM A822	Seamless cold drawn carbon steel tubing for hydraulic system service.
DIN 1630	Seamless circular tubes of non-alloy steel with very high quality requirements. TDC.
DIN 2391	Seamless precision steel tubes.
DIN 2413/1	Steel tubes, calculation of wall thickness of steel tubes subjected to internal pressure.
DIN 2445	Seamless steel tubes for dynamic loads. Part 1: Hot finished tubes in fluid systems, PN 100 to PN 500. Part 2: Steel tubes for precision application in fluid systems, PN 100 to PN 500. Supplement: Design rules.
BS 7416	Precision finished seamless cold drawn low carbon steel tubes for use in hydraulic fluid power systems.
UNI 7945	Plain end seamless precision steel tubes.
NFA 49-330	Seamless cold drawn tubes for hydraulic and pneumatic power systems.
EN 10305-4	Steel tubes for precision applications. Part 4: Seamless cold drawn tubes for hydraulic and pneumatic power systems.
JOHS-102	Carbon steel precision tubes for hydraulic line service.
PN-H 74245	Cold drawn or rolled seamless steel tubes of specified application.

## Dimensions

Dimensions are given in Table 35.

## Tolerances

According to standards, special tolerances could be agreed on request.

## Lengths

- exact lengths 6 000 mm (tolerances - standard lengths 0+50 mm, exact lengths 0+10 mm)
- on request other fixed lengths in the range 3 000 – 9 000 mm

## Straightness

3 mm/m, totally max 0,0015% of tube length.

## Tube ends

Plain ends, plugged with plastic caps.

## Steel grade

Steel is shown in the table of chemical composition and mechanical properties (see page 81).

## Delivery condition

Normalized:

.1 – STN, ČSN NBK - DIN

+N – EN

N – ASTM

Roughness (D and d), d over 15 mm,  $R_a \leq 4 \mu\text{m}$ .

## Micropurity (data upon agreement)

According to NFA 04-106 or ASTM E45 (ranking JK) max. A4 - B2 - C2 - D2. Also according to ISO 4967 or EN 10 247 upon agreement. A - sulphide, B - Alumina, C - Silicate, D - Oxides, DS - Oxides)

## Grain size (data upon agreement)

According to EN ISO 643 - 5 and finer.

## Testing

Non specific inspection or specific inspection. In both cases leak tightness test will be carried out in accordance with EN 10246-1 (electromagnetic test). Other tests according to standards.

## Marking

Each tube shall be marked with Ink-Jet system along whole tube length according to standard or customer's specification. The bundle of tubes shall be marked with a label attached to the bundle.

## Surface protection

- oiled
- phosphated and oiled
- outside surface of tube as chromating – upon agreement only - see page 81

## Packaging

Tubes are packed in round or hexagonal bundles of maximum 2000 kg each, fastened with steel strips. On request – paper below the stripes and plastic bags at the bundle ends.

## Certified test report

According to DIN 50049 and EN 10204:2004

- non specific inspection - 2.2
- specific inspection - 3.1.B., according to EN 3.1
- upon agreement - 3.1.C., according to EN 2.2 (See also page 7)

Pressure chart for hydraulic tubes – see tables 36 (A,B,C,D) page 84 - 87. (Calculation according to DIN 2413)



## Protection of the outer surface of the HPL tubes

### A. GALVANIC PROTECTION OF TUBE SURFACE

The outer surface of HPL tubes (or other types of tubes) can be protected by galvanizing. Coatings in addition to corrosion protection also improve the aesthetic appearance of the product.

The coating usually consists of several layers.

**The first (lower) layer** is galvanic excluded zinc (Zn) or zinc alloy. Layer thickness is 5 - 30 µm.

**The second (eventually middle) layer** consists chromium (Cr). In the past were used Cr 6+ salts, which is toxic. According to the valence of chromium process is called chromating. Using this type of Cr has been forbidden – European Community Directive Nr. 2000/53/EC ( ELV Directive – End of Life Vehicles) and Directive Nr. 2002/95/EC – so-called RoHS conformity – The **Restriction** of use of certain **Hazardous Substances** - Pb, Hg, Cr6+, Cd, PBB-polybrominated biphenyls, PBDE-polybrominated diphenylether. This directive restricts the use of hazardous substances in electrical engineering. Procedures, which are not used banned substances are comply with the Directive. Currently used in the process the Cr3+ salts and process is called chromiting or passivation.

**Last (top) layer** increases the resistance and stability of surface and consists of organic matter containing Si. This process is called impregnation or sealing. This layer may not be applied.

Depending on changes of used procedures (Cr6+ was replaced with Cr3+) has also changed the applicable standards. In the past were valid the standards DIN 50961 and EN 12 229. The Standard EN ISO 2081 has been in use since year 2008. Not even the procedures according to ISO do not guarantee the conformity with requirements of RoHS.

Now is valid new EN ISO 2081, which defines the parameters of the surfaces and their marking. In practice are used two types of surfaces:

- **transparent passivation (thin layer)** is colorless to colored iridescent. For marking is used code **A**.
- **iridescent passivation (thick layer)** is colored iridescent. For marking is used code **C**.
- surface without sealing has not any code, surface with sealing has the code T2
- required thickness of Zn layer in µm (range 5 – 30 µm)
- example for marking of the surface: Fe/Zn8/C means: basic material – steel, layer of Zn min. 8 µm, iridescent passivation, without sealing.

**Dimensional table of Železiarne Podbrezová and Transmesa is in Table 34, page 82.**

### B. PROTECTION OF THE SURFACE OF TUBES WITH PLASTIC LAYER – WITH POLYOLEFIN.

The layer of polyolefin protects the outer surface. It provides mechanical protection, anticorrosion, against chemicals, thermal - insulation and is used for decorative purposes.

Types of tubes coated with polyolefin:

1. HPL tubes non galvanized
2. HPL tubes galvanized with Zn layer 8 – 12 µm
  - iridescent passivation – Fe/Zn8/C
3. Other types of tubes in the size range:

Wall thickness	Outside diameter
1	8 - 22
1,5	8 - 22
2	8 - 22
2,5	14 - 22
3	18 - 22

L = 4 000 – 6 000 mm.

Material – thin-walled, halogen-free polyolefin according to EN 60684, operating temperature - 40 °C until +105°C (short +150°C), tensile strength min. 10 N/mm<sup>2</sup>, elongation min. 300 %, nonflammable, resistant to mildew, oil and chemicals.

## Steels grades, chemical composition and mechanical properties

Standards	Steel	Chemical composition [%]										Mechanical properties					
		C	Si	Mn	Pmax	Smax	Cr	Ni	Mo	Cu	Other	Re min MPa	min ksi	min MPa	Rm max MPa	min ksi	A5 min %
<b>STN, ČSN</b>																	
	11 353	max.0,18			0,050	0,050							235		340	440	25
	11 523	max.0,20	max.0,55	max.1,60	0,050	0,045						Al min.0,015	353		510	628	23
<b>ASTM</b>																	
	A 822	max.0,18		0,27-0,63	0,048	0,058							170	25	310		45 35
<b>DIN</b>																	
1630	St 37.4	max.0,17	max.0,35	min.0,35	0,040	0,040							235		350	480	25
	St 44.4	max.0,20	max.0,35	min.0,40	0,040	0,040							275		420	550	21
	St 52.4	max.0,22	max.0,55	max.1,60	0,040	0,035							355		500	650	21
<b>BS</b>																	
3602/1	CFS 360	max.0,17	max.0,35	0,30-0,80	0,035	0,035						Al max.0,06	235		360	500	25
	CFS 430	max.0,21	max.0,35	0,40-1,20	0,035	0,035						Al max.0,06	275		430	570	22
3603	430 LT	max.0,20	max.0,35	0,60-1,20	0,035	0,035						min.0,020	275		430	570	22
<b>UNI</b>																	
7945	Fe 280	max.0,13		max.0,60	0,050	0,050							155		280		25
	Fe 320	max.0,16		max.0,70	0,050	0,050							195		320		25
	Fe 360	max.0,17	max.0,35	max.0,80	0,050	0,050							215		360		24
	Fe 410	max.0,21	max.0,35	max.1,20	0,050	0,050							235		410		22
	Fe 490	max.0,23	max.0,35	max.1,50	0,050	0,050							285		490		21
<b>NF A</b>																	
49-330	TU 37b	max.0,20	max.0,40	max.0,85	0,045	0,045							220		360	480	23
	TU 42b	max.0,22	max.0,40	max.1,15	0,040	0,040							235		410	510	23
	TU 52b	max.0,22	max.0,55	max.1,60	0,045	0,045							350		510	630	19
<b>EN</b>																	
10305-4	E215	max.0,10	max.0,05	max.0,70	0,025	0,015						Al min.0,025	215		290	430	30
	E235	max.0,17	max.0,35	max.1,20	0,025	0,015							235		350	480	25
	E355	max.0,22	max.0,55	max.1,60	0,025	0,015							355		490	630	22
<b>JIS</b>																	
JOHS-102	OST 1	max.0,20	max.0,55	0,25-0,60	0,040	0,040							180		450		
	OST 2	0,08-0,18	0,10-0,35	0,30-0,60	0,035	0,035					max.0,20		200		450		

Steels according to PN-H type 10, 20, 18G2A, see page 67

### HPL tubes EN 10305-4, steel grade E235+N (optional requirement no. 6)

Surface - Electrolytical layer EN ISO 2081-Fe/Zn8/C (Cr3+) Weight kg/m

Table 34

D [mm]	Wall thickness [mm]														
	0,5	0,75	0,89	1	1,24	1,5	1,65	2	2,11	2,3	2,5	3	3,5	4	5
4	0,043	0,06		0,074											
5		0,079		0,099											
6		0,097		0,123		0,166		0,197							
6,35			0,12		0,156										
8				0,173		0,240		0,296			0,339				
9,52			0,189		0,235		0,320								
10				0,222		0,314		0,395			0,462				
12				0,271		0,388		0,493							
12,7			0,259		0,350		0,450		0,551						
13				0,296		0,425		0,543							
13,5										0,635					
14				0,321		0,462		0,592			0,709	0,814			
15				0,345		0,499		0,641			0,771	0,888			
15,87			0,329		0,445		0,579		0,716						
16				0,370		0,536		0,690			0,832	0,961			
18						0,610		0,789			0,956	1,100			
20				0,469		0,684		0,888			1,079	1,258			
22						0,758		0,986			1,202	1,406	1,597		
25						0,869		1,134			1,387	1,628		2,071	
28						0,980		1,282			1,572	1,85		2,367	
30								1,381				1,997	2,287	2,565	
32								1,488							
35								1,628				2,367		3,058	
38								1,866				2,589		3,354	4,069
42								1,973				2,885		3,748	

TRANSMESA tubes

ŽELEZIARNE PODBREZOVA or TRANSMESA tubes

ŽELEZIARNE PODBREZOVA tubes

- tube marking - INK-JET

- ZP - EN 10305-4 - E235+N - D x T - heat number - Cr VI FREE

- tube length - standard - 6 000 +50 mm

**Dimensions, cross sectional area and weight of HPL tubes**

**Table 35**

Outside diameter [mm]	Wall thickness [mm]	Inside diameter [mm]	Tolerance of inside diameter	Cross sectional area [cm <sup>2</sup> ]	Weight [kg/m]
6	1	4	± 0,12	0,13	0,123
6	1,5	3	± 0,15	0,071	0,166
6	2	2	± 0,15	0,031	0,197
8	1	6	± 0,10	0,28	0,173
8	1,5	5	± 0,10	0,20	0,240
8	2	4	± 0,15	0,13	0,296
10	1	8	± 0,08	0,50	0,222
10	1,5	7	± 0,12	0,38	0,314
10	2	6	± 0,15	0,28	0,395
10	2,5	5	± 0,15	0,20	0,462
12	1	10	± 0,08	0,79	0,271
12	1,5	9	± 0,10	0,64	0,389
12	2	8	± 0,12	0,50	0,493
12	2,5	7	± 0,15	0,38	0,586
12	3	6	± 0,15	0,28	0,666
14	1	12	± 0,08	1,13	0,321
14	1,5	11	± 0,08	0,95	0,462
14	2	10	± 0,12	0,79	0,592
14	3	8	± 0,15	0,50	0,814
15	1	13	± 0,08	1,33	0,345
15	1,5	12	± 0,08	1,13	0,499
15	2	11	± 0,10	0,95	0,641
15	3	9	± 0,15	0,64	0,888
16	1,5	13	± 0,08	1,33	0,536
16	2	12	± 0,15	1,13	0,691
16	2,5	11	± 0,12	0,95	0,832
16	3	10	± 0,15	0,79	0,962
18	1,5	15	± 0,08	1,77	0,610
18	2	14	± 0,08	1,54	0,789
18	2,5	13	± 0,15	1,33	0,956
18	3	12	± 0,15	1,13	1,11
20	1,5	17	± 0,08	2,27	0,684
20	2	16	± 0,08	2,01	0,888
20	2,5	15	± 0,15	1,77	1,08
20	3	14	± 0,15	1,54	1,26
20	4	12	± 0,15	1,13	1,58
22	1,5	19	± 0,08	2,84	0,758
22	2	18	± 0,08	2,55	0,986
22	3	16	± 0,15	2,01	1,41
25	2	21	± 0,08	3,46	1,13
25	2,5	20	± 0,08	3,14	1,39
25	3	19	± 0,15	2,84	1,63
25	4	17	± 0,15	2,27	2,07
25	5	15	± 0,15	1,77	2,47

Outside diameter [mm]	Wall thickness [mm]	Inside diameter [mm]	Tolerance of inside diameter	Cross sectional area [cm <sup>2</sup> ]	Weight [kg/m]
28	1,5	25	± 0,08	4,91	0,980
28	2	24	± 0,08	4,52	1,28
28	3	22	± 0,15	3,80	1,85
28	4	20	± 0,15	3,14	2,37
28	5	18	± 0,15	2,55	2,84
30	2	26	± 0,08	5,31	1,38
30	2,5	25	± 0,08	4,91	1,70
30	3	24	± 0,15	4,52	2,00
30	4	22	± 0,15	3,80	2,57
30	5	20	± 0,15	3,14	3,08
30	6	18	± 0,15	2,55	3,55
35	2	31	± 0,15	7,55	1,63
35	3	29	± 0,15	6,61	2,37
35	4	27	± 0,15	5,73	3,06
35	5	25	± 0,15	4,91	3,70
35	6	23	± 0,15	4,16	4,29
38	2,5	33	± 0,15	8,55	2,19
38	3	32	± 0,15	8,04	2,59
38	4	30	± 0,15	7,07	3,35
38	5	28	± 0,15	6,16	4,07
38	6	26	± 0,15	5,31	4,74
42	2	38	± 0,20	11,34	1,97
42	3	36	± 0,20	10,18	2,89
42	4	34	± 0,20	9,08	3,75
50	4	42	± 0,20	13,85	4,54
50	5	40	± 0,20	12,57	5,55
50	6	38	± 0,20	11,34	6,51
50	8	34	± 0,20	9,08	8,29
55	4	47	± 0,25	17,34	5,03
55	6	43	± 0,25	14,51	7,25
55	8	39	± 0,25	11,95	9,27
55	10	35	± 0,25	9,62	11,10
60	5	50	± 0,25	19,63	6,78
60	8	44	± 0,25	15,20	10,26
60	10	40	± 0,25	12,57	12,33
60	12,5	35	± 0,25	9,62	14,64
70	5	60	± 0,30	28,26	8,02
70	8	54	± 0,30	22,89	12,23
70	10	50	± 0,30	19,63	14,80
70	12,5	45	± 0,30	15,90	17,72
80	6	68	± 0,35	36,30	10,95
80	8	64	± 0,35	32,15	14,21
80	10	60	± 0,35	28,26	17,26
80	12,5	55	± 0,35	23,75	20,81

Tolerances of outside diameter:

D: 6–30 mm ±0,08 mm

D: 35–38 mm ±0,15 mm

D: 42–50 mm ±0,20 mm

D: 55–60 mm ±0,25 mm

D: 70 mm ±0,30 mm

D: 80 mm ±0,35 mm

Other dimensions upon agreement.

**Table of pressures for hydraulic tubes (MPa)  
Steel 37.4 (E235) without specific testing according to 3.1.B (3.1)**

**Table 36A**

Outside diameter [mm]	Wall thickness [mm]														
	0,5	1,0	1,5	2,0	2,5	3,0	3,5	4,0	4,5	5,0	6,0	7,0	8,0	9,0	10,0
5	25,0	49,9													
6	20,8	41,6													
7	17,8	35,7													
8	15,6	31,2	46,8												
9	13,9	27,7	41,6												
10	12,5	25,0	37,4	49,9											
12	10,4	20,8	31,2	41,6											
14	8,9	17,8	26,7	35,7	44,6										
15	8,3	16,6	25,0	33,3	41,6	49,9									
16	7,8	15,6	23,4	31,2	39,0	46,8									
18	6,9	13,9	20,8	27,7	34,7	41,6	48,5								
20	6,2	12,5	18,7	25,0	31,2	37,4	43,7	49,9							
22		11,3	17,0	22,7	28,4	34,0	39,7	45,4	51,0						
24		10,4	15,6	20,8	26,0	31,2	36,4	41,6	46,8						
25		10,0	15,0	20,0	25,0	29,9	34,9	39,9	44,9	49,9					
28		8,9	13,4	17,8	22,3	26,7	31,2	35,7	40,1	44,6					
30		8,3	12,5	16,6	20,8	25,0	29,1	33,3	37,4	41,6	49,9				
32		7,8	11,7	15,6	19,5	23,4	27,3	31,2	35,1	39,0	46,8				
35		7,1	10,7	14,3	17,8	21,4	25,0	28,5	32,1	35,7	42,8				
36		6,9	10,4	13,9	17,3	20,8	24,3	27,7	31,2	34,7	41,6				
38		6,6	9,9	13,1	16,4	19,7	23,0	26,3	29,6	32,8	39,4	46,0			
40		6,2	9,4	12,5	15,6	18,7	21,8	25,0	28,1	31,2	37,4	43,7	49,9		
42			8,9	11,9	14,9	17,8	20,8	23,8	26,7	29,7	35,7	41,6	47,5		
45			8,3	11,1	13,9	16,6	19,4	22,2	25,0	27,7	33,3	38,8	44,4		
48			7,8	10,4	13,0	15,6	18,2	20,8	23,4	26,0	31,2	36,4	41,6	46,8	
50			7,5	10,0	12,5	15,0	17,5	20,0	22,5	25,0	29,9	34,9	39,9	44,9	49,9
52			7,2	9,6	12,0	14,4	16,8	19,2	21,6	24,0	28,8	33,6	38,4	43,2	48,0
55			6,8	9,1	11,3	13,6	15,9	18,2	20,4	22,7	27,2	31,8	36,3	40,8	45,4
58			6,5	8,6	10,8	12,9	15,1	17,2	19,4	21,5	25,8	30,1	34,4	38,7	43,0
60			6,2	8,3	10,4	12,5	14,6	16,6	18,7	20,8	25,0	29,1	33,3	37,4	41,6
62			6,0	8,1	10,1	12,1	14,1	16,1	18,1	20,1	24,2	28,2	32,2	36,2	40,3
65			5,8	7,7	9,6	11,5	13,4	15,4	17,3	19,2	23,0	26,9	30,7	34,6	38,4
70			5,3	7,1	8,9	10,7	12,5	14,3	16,0	17,8	21,4	25,0	28,5	32,1	35,7
75			5,0	6,7	8,3	10,0	11,6	13,3	15,0	16,6	20,0	23,3	26,6	29,9	33,3
80			4,7	6,2	7,8	9,4	10,9	12,5	14,0	15,6	18,7	21,8	25,0	28,1	31,2
85				5,9	7,3	8,8	10,3	11,7	13,2	14,7	17,6	20,6	23,5	26,4	29,4
90				5,5	6,9	8,3	9,7	11,1	12,5	13,9	16,6	19,4	22,2	25,0	27,7
100				5,0	6,2	7,5	8,7	10,0	11,2	12,5	15,0	17,5	20,0	22,5	25,0
110				4,5	5,7	6,8	7,9	9,1	10,2	11,3	13,6	15,9	18,2	20,4	22,7
120					5,2	6,2	7,3	8,3	9,4	10,4	12,5	14,6	16,6	18,7	20,8

Theoretical allowed operating pressure without test certificate [MPa] is calculated according to DIN 2413-93 by 20°C (1 MPa = 10 bar)

The data are informative. The real expected pressures have to fulfill the construction requirements of the device.

**Table of pressure for hydraulic tubes (MPa)  
Steel 37.4 (E235) with specific testing 3.1.B (3.1)**

**Table 36 B**

Outside diameter [mm]	Wall thickness [mm]														
	0,5	1,0	1,5	2,0	2,5	3,0	3,5	4,0	4,5	5,0	6,0	7,0	8,0	9,0	10,0
5	28,3	56,7													
6	23,6	47,2													
7	20,2	40,5													
8	17,7	35,4	53,1												
9	15,7	31,5	47,2												
10	14,2	28,3	42,5	56,7											
12	11,8	23,6	35,4	47,2											
14	10,1	20,2	30,4	40,5	50,6										
15	9,4	18,9	28,3	37,8	47,2	56,7									
16	8,9	17,7	26,6	35,4	44,3	53,1									
18	7,9	15,7	23,6	31,5	39,4	47,2	55,1								
20	7,1	14,2	21,3	28,3	35,4	42,5	49,6	56,7							
22		12,9	19,3	25,8	32,2	38,6	45,1	51,5	58,0						
24		11,8	17,7	23,6	29,5	35,4	41,3	47,2	53,1						
25		11,3	17,0	22,7	28,3	34,0	39,7	45,3	51,0	56,7					
28		10,1	15,2	20,2	25,3	30,4	35,4	40,5	45,5	50,6					
30		9,4	14,2	18,9	23,6	28,3	33,1	37,8	42,5	47,2	56,7				
32		8,9	13,3	17,7	22,1	26,6	31,0	35,4	39,9	44,3	53,1				
35		8,1	12,1	16,2	20,2	24,3	28,3	32,4	36,4	40,5	48,6				
36		7,9	11,8	15,7	19,7	23,6	27,6	31,5	35,4	39,4	47,2				
38		7,5	11,2	14,9	18,6	22,4	26,1	29,8	33,6	37,3	44,7	52,2			
40		7,1	10,6	14,2	17,7	21,3	24,8	28,3	31,9	35,4	42,5	49,6	56,7		
42			10,1	13,5	16,9	20,2	23,6	27,0	30,4	33,7	40,5	47,2	54,0		
45			9,4	12,6	15,7	18,9	22,0	25,2	28,3	31,5	37,8	44,1	50,4		
48			8,9	11,8	14,8	17,7	20,7	23,6	26,6	29,5	35,4	41,3	47,2	53,1	
50			8,5	11,3	14,2	17,0	19,8	22,7	25,5	28,3	34,0	39,7	45,3	51,0	56,7
52			8,2	10,9	13,6	16,4	19,1	21,8	24,5	27,3	32,7	38,2	43,6	49,1	54,5
55			7,7	10,3	12,9	15,5	18,0	20,6	23,2	25,8	30,9	36,1	41,2	46,4	51,5
58			7,3	9,8	12,2	14,7	17,1	19,5	22,0	24,4	29,3	34,2	39,1	44,0	48,9
60			7,1	9,4	11,8	14,2	16,5	18,9	21,3	23,6	28,3	33,1	37,8	42,5	47,2
62			6,9	9,1	11,4	13,7	16,0	18,3	20,6	22,9	27,4	32,0	36,6	41,1	45,7
65			6,5	8,7	10,9	13,1	15,3	17,4	19,6	21,8	26,2	30,5	34,9	39,2	43,6
70			6,1	8,1	10,1	12,1	14,2	16,2	18,2	20,2	24,3	28,3	32,4	36,4	40,5
75			5,7	7,6	9,4	11,3	13,2	15,1	17,0	18,9	22,7	26,5	30,2	34,0	37,8
80			5,3	7,1	8,9	10,6	12,4	14,2	15,9	17,7	21,3	24,8	28,3	31,9	35,4
85				6,7	8,3	10,0	11,7	13,3	15,0	16,7	20,0	23,3	26,7	30,0	33,3
90				6,3	7,9	9,4	11,0	12,6	14,2	15,7	18,9	22,0	25,2	28,3	31,5
100				5,7	7,1	8,5	9,9	11,3	12,8	14,2	17,0	19,8	22,7	25,5	28,3
110				5,2	6,4	7,7	9,0	10,3	11,6	12,9	15,5	18,0	20,6	23,2	25,8
120					5,9	7,1	8,3	9,4	10,6	11,8	14,2	16,5	18,9	21,3	23,6

Theoretical allowed operating pressure without test certificate [MPa] is calculated according to DIN 2413-93 by 20°C (1 MPa = 10 bar)

The data are informative. The real expected pressures have to fulfill the construction requirements of the device.

**Table of pressure for hydraulic tubes (MPa)  
Steel St 52.4 (E355) without specific testing according to 3.1.B (3.1)**

**Table 36 C**

Outside diameter [mm]	Wall thickness [mm]														
	0,5	1,0	1,5	2,0	2,5	3,0	3,5	4,0	4,5	5,0	6,0	7,0	8,0	9,0	10,0
5	36,4	72,8													
6	30,4	60,7													
7	26,0	52,0													
8	22,8	45,5	68,3												
9	20,2	40,5	60,7												
10	18,2	36,4	54,6	72,8											
12	15,2	30,4	45,5	60,7											
14	13,0	26,0	39,0	52,0	65,0										
15	12,1	24,3	36,4	48,6	60,7	72,8									
16	11,4	22,8	34,1	45,5	56,9	68,3									
18	10,1	20,2	30,4	40,5	50,6	60,7	70,8								
20	9,1	18,2	27,3	36,4	45,5	54,6	63,7	72,8							
22		16,6	24,8	33,1	41,4	49,7	57,9	66,2	74,5						
24		15,2	22,8	30,4	37,9	45,5	53,1	60,7	68,3						
25		14,6	21,9	29,1	36,4	43,7	51,0	58,3	65,6	72,8					
28		13,0	19,5	26,0	32,5	39,0	45,5	52,0	58,5	65,0					
30		12,1	18,2	24,3	30,4	36,4	42,5	48,6	54,6	60,7	72,8				
32		11,4	17,1	22,8	28,5	34,1	39,8	45,5	51,2	56,9	68,3				
35		10,4	15,6	20,8	26,0	31,2	36,4	41,6	46,8	52,0	62,4				
36		10,1	15,2	20,2	25,3	30,4	35,4	40,5	45,5	50,6	60,7				
38		9,6	14,4	19,2	24,0	28,8	33,5	38,3	43,1	47,9	57,5	67,1			
40		9,1	13,7	18,2	22,8	27,3	31,9	36,4	41,0	45,5	54,6	63,7	72,8		
42			13,0	17,3	21,7	26,0	30,4	34,7	39,0	43,4	52,0	60,7	69,4		
45			12,1	16,2	20,2	24,3	28,3	32,4	36,4	40,5	48,6	56,7	64,8		
48			11,4	15,2	19,0	22,8	26,6	30,4	34,1	37,9	45,5	53,1	60,7	68,3	
50			10,9	14,6	18,2	21,9	25,5	29,1	32,8	36,4	43,7	51,0	58,3	65,6	72,8
52			10,5	14,0	17,5	21,0	24,5	28,0	31,5	35,0	42,0	49,0	56,0	63,0	70,0
55			9,9	13,2	16,6	19,9	23,2	26,5	29,8	33,1	39,7	46,4	53,0	59,6	66,2
58			9,4	12,6	15,7	18,8	22,0	25,1	28,3	31,4	37,7	44,0	50,2	56,5	62,8
60			9,1	12,1	15,2	18,2	21,2	24,3	27,3	30,4	36,4	42,5	48,6	54,6	60,7
62			8,8	11,7	14,7	17,6	20,6	23,5	26,4	29,4	35,2	41,1	47,0	52,9	58,7
65			8,4	11,2	14,0	16,8	19,6	22,4	25,2	28,0	33,6	39,2	44,8	50,4	56,0
70			7,8	10,4	13,0	15,6	18,2	20,8	23,4	26,0	31,2	36,4	41,6	46,8	52,0
75			7,3	9,7	12,1	14,6	17,0	19,4	21,9	24,3	29,1	34,0	38,9	43,7	48,6
80			6,8	9,1	11,4	13,7	15,9	18,2	20,5	22,8	27,3	31,9	36,4	41,0	45,5
85				8,6	10,7	12,9	15,0	17,1	19,3	21,4	25,7	30,0	34,3	38,6	42,9
90				8,1	10,1	12,1	14,2	16,2	18,2	20,2	24,3	28,3	32,4	36,4	40,5
100				7,3	9,1	10,9	12,7	14,6	16,4	18,2	21,9	25,5	29,1	32,8	36,4
110				6,6	8,3	9,9	11,6	13,2	14,9	16,6	19,9	23,2	26,5	29,8	33,1
120					7,6	9,1	10,6	12,1	13,7	15,2	18,2	21,2	24,3	27,3	30,4

Theoretical allowed operating pressure without test certificate [MPa] is calculated according to DIN 2413-93 by 20°C (1 MPa = 10 bar)

The data are informative. The real expected pressures have to fulfill the construction requirements of the device.



**Table of pressure for hydraulic tubes (MPa)  
Steel St 52.4 (E355) with specific testing 3.1.B (3.1)**

**Table 36D**

Outside diameter [mm]	Wall thickness [mm]														
	0,5	1,0	1,5	2,0	2,5	3,0	3,5	4,0	4,5	5,0	6,0	7,0	8,0	9,0	10,0
5	40,3	80,5													
6	33,5	67,1													
7	28,8	57,5													
8	25,2	50,3	75,5												
9	22,4	44,7	67,1												
10	20,1	40,3	60,4	80,5											
12	16,8	33,5	50,3	67,1											
14	14,4	28,8	43,1	57,5	71,9										
15	13,4	26,8	40,3	53,7	67,1	80,5									
16	12,6	25,2	37,7	50,3	62,9	75,5									
18	11,2	22,4	33,5	44,7	55,9	67,1	78,3								
20	10,1	20,1	30,2	40,3	50,3	60,4	70,4	80,5							
22		18,3	27,4	36,6	45,7	54,9	64,0	73,2	82,3						
24		16,8	25,2	33,5	41,9	50,3	58,7	67,1	75,5						
25		16,1	24,2	32,2	40,3	48,3	56,4	64,4	72,5	80,5					
28		14,4	21,6	28,8	35,9	43,1	50,3	57,5	64,7	71,9					
30		13,4	20,1	26,8	33,5	40,3	47,0	53,7	60,4	67,1	80,5				
32		12,6	18,9	25,2	31,5	37,7	44,0	50,3	56,6	62,9	75,5				
35		11,5	17,3	23,0	28,8	34,5	40,3	46,0	51,8	57,5	69,0				
36		11,2	16,8	22,4	28,0	33,5	39,1	44,7	50,3	55,9	67,1				
38		10,6	15,9	21,2	26,5	31,8	37,1	42,4	47,7	53,0	63,6	74,2			
40		10,1	15,1	20,1	25,2	30,2	35,2	40,3	45,3	50,3	60,4	70,4	80,5		
42			14,4	19,2	24,0	28,8	33,5	38,3	43,1	47,9	57,5	67,1	76,7		
45			13,4	17,9	22,4	26,8	31,3	35,8	40,3	44,7	53,7	62,6	71,6		
48			12,6	16,8	21,0	25,2	29,4	33,5	37,7	41,9	50,3	58,7	67,1	75,5	
50			12,1	16,1	20,1	24,2	28,2	32,2	36,2	40,3	48,3	56,4	64,4	72,5	80,5
52			11,6	15,5	19,4	23,2	27,1	31,0	34,8	38,7	46,5	54,2	61,9	69,7	77,4
55			11,0	14,6	18,3	22,0	25,6	29,3	32,9	36,6	43,9	51,2	58,6	65,9	73,2
58			10,4	13,9	17,4	20,8	24,3	27,8	31,2	34,7	41,6	48,6	55,5	62,5	69,4
60			10,1	13,4	16,8	20,1	23,5	26,8	30,2	33,5	40,3	47,0	53,7	60,4	67,1
62			9,7	13,0	16,2	19,5	22,7	26,0	29,2	32,5	39,0	45,5	51,9	58,4	64,9
65			9,3	12,4	15,5	18,6	21,7	24,8	27,9	31,0	37,2	43,4	49,5	55,7	61,9
70			8,6	11,5	14,4	17,3	20,1	23,0	25,9	28,8	34,5	40,3	46,0	51,8	57,5
75			8,1	10,7	13,4	16,1	18,8	21,5	24,2	26,8	32,2	37,6	42,9	48,3	53,7
80			7,5	10,1	12,6	15,1	17,6	20,1	22,6	25,2	30,2	35,2	40,3	45,3	50,3
85				9,5	11,8	14,2	16,6	18,9	21,3	23,7	28,4	33,2	37,9	42,6	47,4
90				8,9	11,2	13,4	15,7	17,9	20,1	22,4	26,8	31,3	35,8	40,3	44,7
100				8,1	10,1	12,1	14,1	16,1	18,1	20,1	24,2	28,2	32,2	36,2	40,3
110				7,3	9,1	11,0	12,8	14,6	16,5	18,3	22,0	25,6	29,3	32,9	36,6
120					8,4	10,1	11,7	13,4	15,1	16,8	20,1	23,5	26,8	30,2	33,5

Theoretical allowed operating pressure without test certificate [MPa] is calculated according to DIN 2413-93 by 20°C (1 MPa = 10 bar)

The data are informative. The real expected pressures have to fulfill the construction requirements of the device.

## Tubes for bearing production

### Dimensions of precision tubes for manufacturing of bearing:

Table 37

Outside diameter [mm]	Wall thickness [mm]
22–25	3–4,1
25,01–29	3–5
29,01–32	3–6,7
32,01–40	3–7,8
40,01–70	3–8

#### Tolerances

##### outside diameter

D < 50 mm:	0 + 0,15 mm
D ≥ 50 mm:	0 + 0,25 mm

##### wall thickness

± 7,5 % (upon agreement ± 5 %)

#### Lengths

3 000 ± 500 mm

#### Straightness

1 mm/1000 mm, max 2,5 mm/3000 mm

#### Steel grade

DIN 17 230 – 100Cr6 (or 14 109 according STN, ČSN).

C	Mn	Si	P	S	Cr	Ni	Cu	Sn
0,90 1,10	0,30 0,50	0,15 0,30	max 0,017	max 0,015	1,30 1,65	max 0,10	max 0,15	max 0,010

#### Delivery condition (heat treatment)

GKZ + K + G – annealed for globular carbide + cold finished + soft annealed.

#### Hardness

After soft annealing is 174 – 220 HB. Dispersion of hardness along the tube length max 15 HB. Hardness by quenching test is min 61 HRC.

#### Surface condition

The tubes are delivered with surface after soft annealing. Max depth of defects is 0,25 mm inclusive decarbonizing.

#### Microstructure

Tested according to SEP 1520:

- size of carbide 2.1 – 2.3
- lamellar pearlite 3.0
- carbide net 5.2
- carbide line spacing max 6.3 – continuous  
max 7.3 – released

#### Micropurity

Tested according to DIN 50602. Total value (oxide + sulphide) K3 ≤ 10.

#### Demagnetizing

Residual magnetism max 10 Oe.

#### Tube ends

Plain square cut ends, one end bevelled 0,5–4 mm x 45°.

#### Testing

Testing according to DIN 17 230. NDT upon agreement according to EN 10246-3 E2H and EN 10246-7 U2/B and test of material identification of alloy steel.

#### Marking

Bundles are marked with label.

#### Surface protection

Oiled.

#### Packaging

Tubes are packed in bundles of weight of 1 000–3 000 kg.

#### Certified test report

According to DIN 50049 - EN 10204 - 3.1.B. (3.1).

#### Notes:

1. Possible to deliver also in condition Hot finished.
2. Deliveries according standard EN ISO 683-17 too:
  - Dimensions and tolerances upon agreement.
  - Surface condition and designation:
    - Hot formed – without or HW
    - Cold drawn – CD
  - Heat treatment and delivery condition:
    - Without heat treatment – without or +U
    - Heat treatment for spheroidization and cold drawn +AC+C
    - Heat treatment for spheroidization +AC

## Precision tubes, delivered in coils

Precision steel tubes, delivered in coils, find its application in many fields of industry for example as injection tubes for diesel engines, tubes for distribution of oil or fuel. Tubes in coils are delivered in accordance with EN 10305-1 (EN 10305-2) and DIN 2391 (DIN 2393).

### Dimensions of tubes in coils

Tubes are delivered in a range, outside diameter between 4 and 18 mm, wall thickness between 0.45 and 2.5 mm. Other dimensions may be delivered upon agreement. For application to injection equipments of combustion engines (diesel) following dimensions of tubes may be delivered: 6x1, 8; 6x2,1; 6x2,125; 6x2,2; 6x2,25 mm. Diameter of the coil alone is between 750 and 1200 mm depending upon the outside diameter of the tubes. Depending upon the outside diameter of the tube, inside in the bundle there is a tube with a length between 60 to 560 m (max coil weight is 50 kg).

### The types of tubes' steel in coils

E 215, E 235, E 255, E 355, C 15, other grades upon agreement. Injection tubes are produced from the St 30Al steel a SAE 1010.

### Tubes in bundles – delivery condition

+C (BK)	Cold drawn / hard. After the last cold forming, thermally not processed.
+N (NBK)	Normalized. After the last cold drawing the tubes are normalized in protective atmosphere.
+LC +A +SR	

### Tolerances

Tube tolerances are in accordance with EN 10305-1, see table 25 page 69. D tolerances for product range is  $\pm 0,08$  mm, d tolerances are  $\pm 0,08$  mm or  $\pm 0,15$  mm depends on D and wall thickness tolerances are  $\pm 10$  %. The reduced tolerances have to be agreed.

### Surface conditions

Surface fulfilled requirements of EN 10305 – 1.  $R_a \leq 3\mu\text{m}$ .

### Packaging of the tubes in coils

Bundles of tubes are packaged into paper boxes weighing between 100 to 120 kilograms which are subsequently stored on wooden pallets or into metal containers weighing up to 400 kilograms.

### Surface protection and marking

Tubes in coils are marked with labels. A label contains all information requested by the standards. The tube outside surface is oiled. The tube inside surface is oiled in delivery condition +C or +LC. There is not tube surface protection in delivery conditions +N, +SR and +A.

### Testing of the tubes in coils

Tubes are tested by eddy current according to EN 10246-3.

### Certificates for tubes in coils

Certificates are issued according to EN 10204/3.1.

## Cut and bent tubes

Specially designed tube semi-finished products, tailored to customer's needs are available upon request. Cold drawn precise tubes are machined, but when requested, hot finished tubes are furnished as various forms of semi finished products.

### Products

- Tube cut in short exact lengths by:
  - sawing
  - shearing
  - rotary cut-off head with slides
- Tube with bevelled ends
- Tube bending

Dimensions of tube bends

Table 38

	Bend angle Rm											
	20	25	32	40	50	60	80	100	125	160	200	250
D = 10 t ≥ 1												
D = 12 t ≥ 1												
D = 14 t ≥ 1												
D = 15 t ≥ 1												
D = 16 t ≥ 1												
D = 18 t ≥ 1												
D = 20 t ≥ 1												
D = 22 t ≥ 1												
D = 24 t ≥ 1												
D = 25 t ≥ 1												
D = 28 t ≥ 1												
D = 30 t ≥ 1,5												
D = 32 t ≥ 1,5												
D = 35 t ≥ 1,5												
D = 38 t ≥ 1,5												
D = 40 t ≥ 1,5												
D = 42 t ≥ 1,5												

$t = D/20$   
 $R_i = 2D$

$t = D/30$   
 $R_i = 3D$

$t = D/50$   
 $R_i = 4,5D$

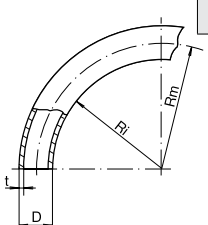

It is possible to bend the tubes in three planes without destroying the tube at the bend point (see table) by CNC tube bender. Bend parameters:

- max. size of bent tube – 42 x 2,5 mm
- bend radius – 12–260 mm
- max. bend angle – 187 °
- tolerance on bend angle – ±0,1°
- tube length under the final bend – max 3 000 mm
- tolerance of length – ±0,1 mm

### Packaging

Semi-finished products are delivered according to customer specifications in mettalic box pallets, collapsible pallets, cardboard cartons placed on wooden europallets or bundled.

### Certified test report

According to DIN 50049 - EN 10204 - 2.2 or 3.1.

Parameter	Method			
	Sawing 1	Sawing 2	Shearing	Rotary cutt-off
<b>Outside diameter</b>	12–102 mm	10–81 mm	15–152 mm	20–90 mm
<b>Wall thickness</b>	1–3 mm	0,5–7 (12) mm	max. 7% D	0,7–12 mm
<b>Lenghts</b>	20 (130)–3250 mm	15–600 mm	25–780 mm	150–2000 mm
<b>Tolerances</b>	±0,25 mm	±0,025 mm	±0,25 mm	±0,11– ±0,19 mm
<b>Stabilization of production process</b>		CpK > 1,67		CpK > 1,67
<b>Tube ends</b>	Brushing L = 130(250)–3980 mm	Tube ends bevelling		
		D = 10–81 mm L = 15–340 mm 5°–85° (min. d = 12 mm)	D = 15–70 mm L = 30–690 mm	D = 20–90 mm L = 150–2000 mm 5°–85° (min. d = 18 mm)
<b>Surface protection</b>	Washing and passivating at L = 100–3000 mm	Without protection or oiled		

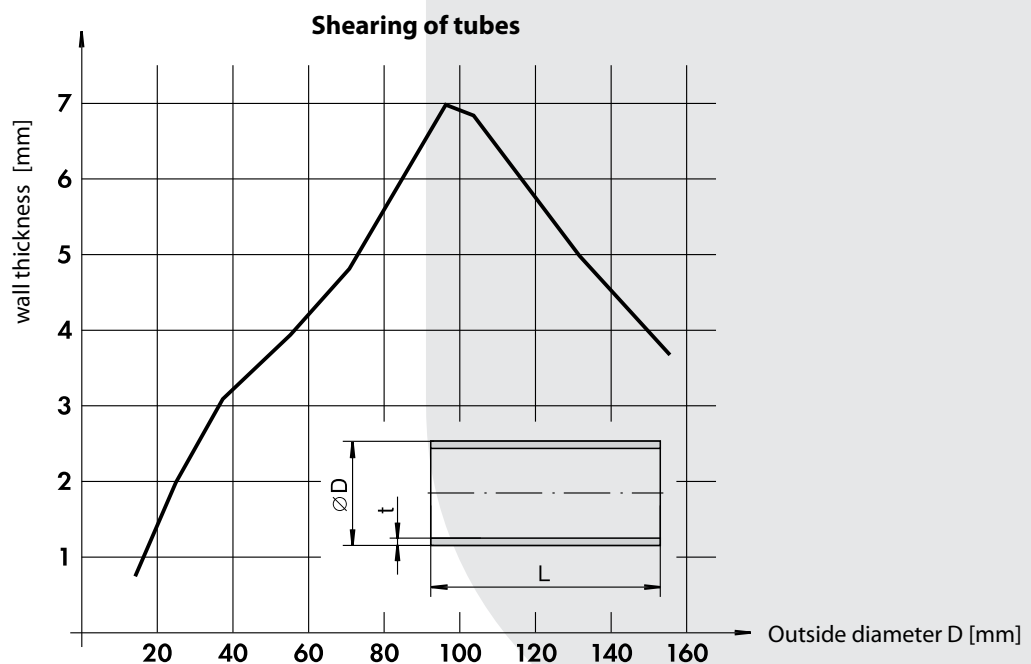
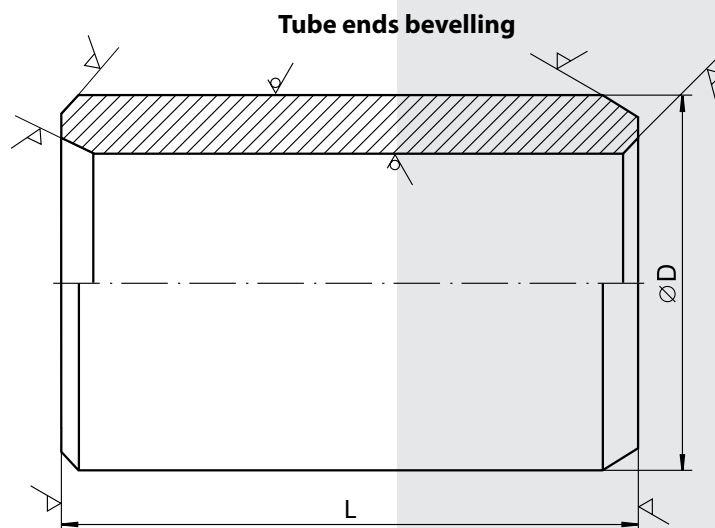

## Butt-welding steel pipe fittings

### List of standards of butt welding elbows

Standards	Dimensional standards	Dimensions	Standards for elbows		Standards for pipe	
			TDC	Steel grade	TDC	Steel grade
<b>Elbows for steel construction, machine parts and common use – standard steel</b>						
<b>STN, ČSN</b>	42 5760	Table 40 Page 94	ŽP-05-04	11 353	42 0250	11 353
<b>DIN</b>	2605 - 1, 2		2609 (A) 2609 (B) 2609 (C)	St 37.0 St 44.0 St 52.0	1629	St 37.0 St 44.0 St 52.0
<b>EN</b>	10 253 - 1		10 253 - 1	S 235 S 265	10 210 - 1	S 235 JRH S 275 JOH
<b>Elbows for pressure purposes – room temperature</b>						
<b>STN, ČSN</b>	42 5760	Table 40 Page 94	ŽP-05-04	11 353	42 0250	11 353
<b>DIN</b>	2605 - 1, 2		2609 (A) 2609 (B) 2609 (C)	St 37.0 St 44.0 St 52.0	1629	St 37.0 St 44.0 St 52.0
<b>NF A</b>	49 - 186 49 - 281		49 - 186 49 - 281	AE 220 A AE 220, 250, 275	49 112	TU E 220A TU E 235A
<b>EN</b>	10 253 - 2	10 253 - 2	P 235 TR2 P 265 TR2 P 235 TR2 P 265 TR2	10 216 - 1	P 235 TR1 P 265 TR1 P 235 TR2 P 265 TR2	
<b>Elbows for pressure purposes – elevated temperature</b>						
<b>STN, ČSN</b>	42 5760 15 020	Table 40 Page 94	ŽP-05-05 15 020	12 021 12 022	42 0251	12 021 12 022
<b>ASTM ASME</b>	ANSI B 16.9	Table 41 Page 95	A 234 / A 960	WPB WPC	A 106	Grade B Grade C
<b>DIN</b>	2605 - 1, 2	Table 40 Page 94	2609 (F, G) 2609 (H)	St 35.8 I, III 15Mo3	17 175	St 35.8 I, III 15Mo3
<b>BS</b>	1965 - 1		1965 - 1	Grade 410	3602 - 1	HFS 360
<b>EN</b>	10 253 - 2		10 253 - 2	P 235 GH P 265 GH 16Mo3	10 216 - 2	P 235 GH P 265 GH 16Mo3
<b>Elbows for pressure purposes from fine grain steel</b>						
<b>DIN</b>	2605 - 1, 2	Table 40 Page 94	2609 (R) 2609 (S) 2609 (T)	WStE 355 TStE 355 TStE 285	17 179	WStE 355 TStE 355 TStE 285
<b>EN</b>	10 253 - 2		10 253 - 2	P 355 N P 355 NH P 355 NL1	10 216 - 3	P 355 N P 355 NH P 355 NL1
<b>Elbows for pressure purposes – low temperature</b>						
<b>PN ŽP</b>	42 5760	Table 40 Page 94	ŽP-05-04	11 369 11 419 11 503	42 0165	11 369 11 419 11 503
<b>ASME</b>	ASME B 16.9	Table 41 Page 95	A 420 / A 960	WPL 6	A 333	Grade 6
<b>EN</b>	10 253 - 2	Table 40 Page 94	10 253 - 2	P 215 NL P 265 NL	10 216 - 4	P 215 NL P 265 NL
<b>Elbows for water and gas pipe line</b>						
<b>PN ŽP</b>	42 5760	Table 40 Page 94	ŽP-05-04	11 353	42 0250	11 353
<b>DIN</b>	2605 - 1		2609 (A)	St 37.0	2440, 2441	St 33-2, St 37.0
<b>Elbows for pipe line</b>						
<b>DIN</b>	2605 - 1, 2	Table 40 Page 94	2609 (D) 2609 (E)	StE 290.7 StE 360.7	17 172	StE 290.7 StE 360.7
<b>EN</b>	10 253 - 2		10 253 - 2	L 415NE	EN ISO 3183	L 415NE



## List of dimensional standards and technical delivery conditions standards for fittings

---

ŽP-05-04	Buttwelding elbows. TDC.
ŽP-05-05	Buttwelding elbows with specified elevated temperature properties
STN 42 0165	ČSN 42 0165 Sheets and pipes of ferritic-perlitic steel with guaranteed impact properties at low temperatures. TDC.
STN 42 0250	ČSN 42 0250 Hot formed seamless tubes from steel grade 10 to 16.
STN 42 0251	ČSN 42 0251 Seamless steel tubes with specified elevated temperature properties.
ŽP 42 5760	Buttwelding elbows. Dimensions.
ASME B16.9	Factory-made wrought steel buttwelding fittings.
ASTM A106	Seamless carbon steel pipe for high temperature service.
ASTM A234	Piping fittings of wrought carbon steel and alloy steel for moderate and high temperature service.
ASTM A333	Seamless and welded steel pipe for low temperature service (Pipe).
ASTM A420	Piping fittings of wrought carbon steel and alloy steel for low temperature service.
ASTM A860/MSS-SP-75 (MSS for dimension NPS over 14)	Wrought high strength low alloy steel butt welding fittings. (Steel grade WPHY 42, 46, 52, 60, 65, 70). Deliveries upon agreement, NPS above 14 inch.
ASTM A960	Common requirements for wrought steel piping fittings.
ASTM A999	General requirements for alloy and stainless steel pipe.
ASTM A1016	General requirements for ferritic alloy steel, austenitic alloy steel and stainless steel tubes.
DIN 1629	Seamless circular tubes of non-alloy steel with special quality requirements.
DIN 2440	Steel tubes, medium weight suitable for screwing.
DIN 2441	Steel tubes, heavy weight suitable for screwing.
DIN 2519	Steel flanges. TDC.
DIN 2605-1	Elbows. Reduced correlation of utilization.
DIN 2605-2	Elbows. Full correlation of utilization.
DIN 2609	Buttwelding fittings.
DIN 17 172	Steel pipes for long-distance pipelines for combustible liquids and gases.
DIN 17 175	Seamless tubes of heat resistant steel.
DIN 17 179	Seamless circular fine grain steel tubes to special requirements.
BS 1965-1	Buttwelding pipe fittings for pressure purposes. Carbon steel.
BS 3602-1	Steel pipes and tubes for pressure purposes: carbon and carbon manganese steel with specified elevated temperature properties.
NF A49-112	Plain ends seamless steel hot rolled tubes with specified room temperature properties and with special delivery conditions.
NF A49-186	Tubular accessories – bends – reduction for welding, made from seamless tubes for general use. Dimensions. TDC.
NFA 49-281	Steel tubes, tubular accessories, bends, tee, reduction for welding, made from seamless tube with quality specifications. Dimensions. TDC.
EN 764-5	Pressure equipment. Part 5: Metal part check document and material conformity.
EN ISO 3183	Steel tubes for pipeline transportation system
EN 10210-1	Hot finished structural hollow sections of non-alloy and fine grain structural steel.
EN 10216-1, 2, 3, 4	Seamless steel tubes for pressure purposes. TDC. Part 1: Non-alloy steel tubes with specified room temperature properties. Part 2: Non-alloy and alloy steel tubes with specified elevated temperature properties. Part 3: Non-alloy and alloy fine grain steel tubes Part 4: Non-alloy and alloy steel tubes with specified low temperature properties.
EN 10253-1	Buttwelding pipe fittings. Part 1: Wrought carbon steel for general use and without specific inspection requirements.
EN 10253-2	Buttwelding pipe fittings. Part 2: Wrought carbon and ferritic alloy steel with specific inspection requirements.
EN 10297-1	Seamless steel tubes for mechanical and general engineering purposes. TDC. Part 1: Non-alloy and alloy steel tubes.
ISO 3419	Non-alloy and alloy steel buttwelding fittings.
RToD M0803	Dutch rules for pressure vessels. Seamless fittings.

## Dimensions of elbows

### Dimensions of butt welding elbows shape K (90°) and DK (180°) type 3D, produced by European standards

Table 40

Size		Outside diameter (mm)	Wall thickness (mm)	Long radius r (mm)	Height b (mm)	2b (mm)	Elbow weight	
NPS	DN						90° (kg)	180° (kg)
1/2	15	21,3	2,00	28	38	76	0,04	0,08
3/4	20	26,9	2,30	29	43	86	0,07	0,13
3/4	20	26,9	2,60	29	43	86	0,07	0,14
3/4	20	26,9	2,90	29	43	86	0,08	0,15
3/4	20	26,9	3,20	29	43	86	0,08	0,16
		31,8	2,60	35	51	102	0,10	0,20
1	25	33,7	2,60	38	56	112	0,13	0,26
1	25	33,7	3,20	38	56	112	0,15	0,30
1	25	33,7	3,60	38	56	112	0,16	0,32
		38,0	2,60	45	64	128	0,17	0,34
1 1/4	32	42,4	2,60	48	69	138	0,20	0,40
1 1/4	32	42,4	2,60	48	69	138	0,25	0,5
1 1/4	32	42,4	3,60	48	69	138	0,28	0,56
1 1/4	32	42,4	4,00	48	69	138	0,31	0,62
		44,5	2,60	51	73	146	0,22	0,44
1 1/2	40	48,3	2,60	57	82	164	0,27	0,54
1 1/2	40	48,3	3,20	57	82	164	0,34	0,68
1 1/2	40	48,3	3,60	57	82	164	0,36	0,72
1 1/2	40	48,3	4,00	57	82	164	0,40	0,80
		51,0	2,60	63,5	88	176	0,31	0,62
		57,0	2,90	72	100	200	0,44	0,88
		57,0	4,00	72	100	200	0,59	1,18
2	50	60,3	2,90	76	106	212	0,49	0,98
2	50	60,3	3,60	76	106	212	0,63	1,26
2	50	60,3	4,00	76	106	212	0,71	1,42
2	50	60,3	4,50	76	106	212	0,79	1,58
2	50	60,3	5,00	76	106	212	0,89	1,78
		63,5	2,90	82,5	114	228	0,56	1,12
		70,0	2,90	92	127	254	0,69	1,38
2 1/2	65	76,1	2,90	95	133	266	0,80	1,60
2 1/2	65	76,1	3,60	95	133	266	0,98	1,96
2 1/2	65	76,1	4,00	95	133	266	1,06	2,12
2 1/2	65	76,1	4,50	95	133	266	1,22	2,44
2 1/2	65	76,1	5,00	95	133	266	1,36	2,74
		82,5	3,20	107,5	149	298	1,06	2,12
3	80	88,9	3,20	114	159	318	1,22	2,44
3	80	88,9	4,00	114	159	318	1,50	3,00
3	80	88,9	4,50	114	159	318	1,69	3,38
3	80	88,9	5,60	114	159	318	2,13	4,26
		101,6	3,60	133,5	184	368	1,86	3,72
		108,0	3,60	142,5	196	392	2,12	4,24
		108,0	4,00	142,5	196	392	2,42	4,84
4	100	114,3	3,60	152	210	420	2,36	4,72
4	100	114,3	4,00	152	210	420	2,63	5,26
4	100	114,3	4,50	152	210	420	2,95	5,90
4	100	114,3	6,30	152	210	420	4,13	8,26
		127,0	4,00	175	238	476	3,34	6,68
		133,0	4,00	181	247	494	3,75	7,50
5	125	139,7	4,00	190	260	520	4,10	8,20
		152,4	4,50	215	291	582	5,54	11,08
		159,0	4,50	216	294	588	6,10	12,20
6	150	168,3	4,50	229	313	626	6,80	13,60
7	175	193,7	5,60	270	367	734	10,60	21,20
8	200	219,1	6,30	305	414	828	15,80	31,60
10	250	273,0	6,30	381	518	1036	24,80	49,60
10	250	273,0	7,10	381	518	1036	27,90	55,80
12	300	323,9	7,10	457	619	1238	39,80	79,60
14	350	355,6	8,00	533	711	1422	57,50	115,00
16	400	406,4	8,80	610	813	1626	82,60	165,20
18	450	457,0	10,00	686	914	1828	119,00	237,00
20	500	508,0	11,00	762	1016	2032	162,00	323,00
24	600	610,0	12,50	914	1219	2438	266,00	531,00

Dimensions of butt welding elbows, manufactured according to ASME (ANSI) B 16.9 standard

Table 41

NPS	Outside diameter		Wall thickness		Identification	Schedule No.	Inside diameter		90° elbow A (r)		180° elbow			
	[inch]	[mm]	[inch]	[mm]			[inch]	[mm]	[inch]	[mm]	O		K	
											[inch]	[mm]	[inch]	[mm]
1	1.315	33,4	0.133	3,38	STD	40	1.049	26,64	1.50	38	3.00	76	2.19	56
1 1/4	1.660	42,2	0.140	3,56	STD	40	1.380	35,08	1.88	48	3.75	95	2.75	70
1 1/2	1.900	48,3	0.145	3,68	STD	40	1.610	40,94	2.25	57	4.50	114	3.25	83
2	2.375	60,3	0.109	2,77	-	-	2.157	54,76	3.00	76	6.00	152	4.19	106
2	2.375	60,3	0.154	3,91	STD	40	2.067	52,48	3.00	76	6.00	152	4.19	106
2 1/2	2.875	73,0	0.203	5,16	STD	40	2.469	62,68	3.75	95	7.50	191	5.19	132
3	3.500	88,9	0.125	3,18	-	-	3.250	82,54	4.50	114	9.00	229	6.25	159
3	3.500	88,9	0.216	5,49	STD	40	3.068	77,92	4.50	114	9.00	229	6.25	159
3 1/2	4.000	101,6	0.141	3,58	-	-	3.718	94,44	5.25	133	10.50	267	7.25	184
3 1/2	4.000	101,6	0.226	5,74	STD	40	3.548	90,12	5.25	133	10.50	267	7.25	184
4	4.500	114,3	0.141	3,58	-	-	4.218	107,14	6.00	152	12.00	305	8.25	210
4	4.500	114,3	0.237	6,02	STD	40	4.026	102,26	6.00	152	12.00	305	8.25	210
6	6.625	168,3	0.172	4,37	-	-	6.281	159,56	9.00	229	18.00	457	12.31	313

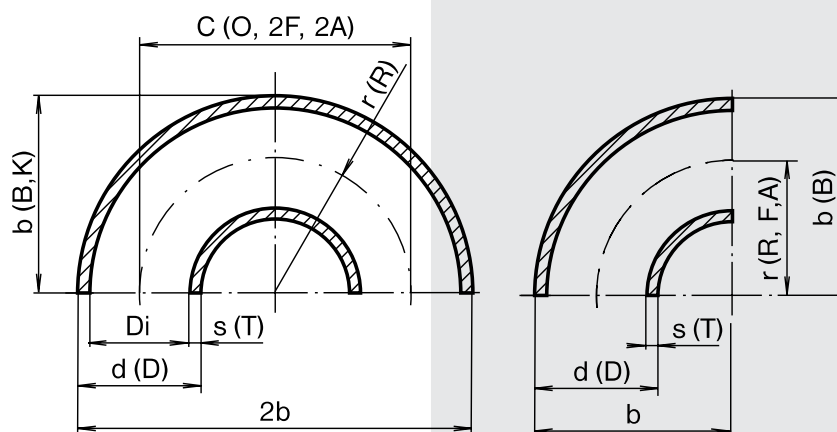

Standard		Symbols					
PN ŽP 42 5760	DN	d	s	r	b	2b	b
DIN 2605	DN	d <sub>a</sub>	s	r	b	2b	b
NF A 49 186	DN	D	T	(R)	F	C	B
EN 10 253	DN	D	T	(R)	F	C	B
BS 1965	NPS	(D)	(T)		A	O	K
ASME B 16.9	NPS	D			A	O	K

## Dimensional tolerances

Exact values are listed in corresponding standards. Approximate data are shown in the Table 42 of tolerances (page 97).

## Steel

Elbows are made from steel shown in survey table at page 92. At standard DIN 2609 there is shown also steel qualification according to this standard. As a supplement of the survey there is listed also standard and steel grade of tube which is a part of pipeline together with elbow.

Elbow verify according to requirements of standard NACE MR 0103, NACE MR 0175. C-equivalent calculating formula see page 103.

## Heat treatment, delivery condition and surface quality

The elbows are made by hot forming process and they are delivered without heat treatment. Normalising includes normalising forming. Surface quality is corresponding to manufacturing process. Upon agreement - sand blasting of outside surface.

## End preparation

Elbows are delivered with plain ends. Preparation of ends for welding (beveling) according to standards:

- STN, ČSN 13 1075
- ASME (ANSI) B16.9
- DIN 2559
- EN 10 253 and other EN standards
- NFA 29-032 and standards for pipes
- ISO 6761

## Trimming the elbows ends:

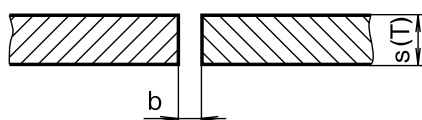

DIN	T < 3 mm (Tvar 1)
EN	T < 3 mm
ANSI (ASME)	T < 3 (5) mm
ČSN, STN	T < 2,6 (3-4) mm (according method of welding)

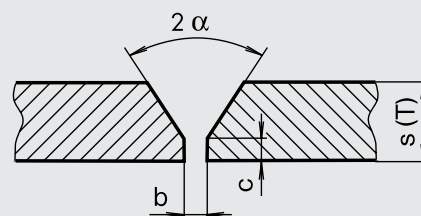

DIN	T = 3-16 mm (Tvar 22)
	2α = 40°-60°, c = do 2 mm
EN	T = 3-20 mm <sup>1)</sup>
	α = 30° 0° +5°
	c = 1,6 ±0,8 mm
ANSI (ASME)	T < 22 mm <sup>2)</sup>
	α = 37,5° ±2,5°
	c = 1,6 ±0,8 mm
	(c = 1/16 ±1/32 inch)
ČSN, STN	T = 3-20 mm
	2α = 70° ±2°
	c = 1,5 +0,5 mm
	(T = 2,9-11 mm)

## Testing

Pipes as a raw material and finished elbows are tested according to corresponding standards.

## Marking

The elbows are delivered with marking:

- without marking
- colour marking - steel grade according to corresponding standard
- stamping of data according to standard, customer's requirements or equipment possibilities (size of elbow).

## Surface protection

The elbows are delivered without surface protection. Temporary protection with oil upon agreement.

## Packaging

Fittings are packed in cartons, placed on wooden pallets, or in matalic box pallets.

## Certificates

Certification in accordance with the following standards:

STN, ČSN 42 0165, 42 0250, 42 0251

ASTM A234/A234, A420/A420M

DIN 50049 - 2.2, 3.1.A, 3.1.B, 3.1.C

EN 10 204 - for EN 10253-1 - 2.2 (non-specific testing)

- for EN 10253-2 - 3.1.B (specific testing) eventually 3.1.A, 3.1.C, 3.2 (see also page 7)

## Steels grades, chemical composition and mechanical properties (indicative values)

Standards	Steel grade	Chemical composition [%]										Mechanical properties					
		C	Si	Mn	Pmax	Smax	Cr	Ni	Mo	Cu	Other	Re min MPa	min ksi	min MPa	Rm max MPa	min ksi	A5 min %
<b>STN, ČSN</b>																	
	11 353	max.0,18			0,050	0,050						235	340	440	25		
	11 369	max.0,14	max.0,35	max.0,80	0,040	0,040	max.0,30	max.0,30		max.0,30	Al min.0,020	226	353	441			
	11 419	max.0,20	max.0,35	max.0,80	0,040	0,040	max.0,30	max.0,30		max.0,30	Al min.0,020	255	400	490			
	11 503	max.0,18	max.0,40	max.1,40	0,035	0,035	max.0,30	max.0,30		max.0,30	Nb min.0,015	355	490	630	22		
	12 021	0,07 - 0,15	0,17 - 0,35	0,35 - 0,60	0,040	0,040	max.0,25	max.0,25		max.0,25		235	340	470	25		
	12 022	0,15 - 0,22	0,17 - 0,37	0,50 - 0,60	0,040	0,040	max.0,25	max.0,25		max.0,25		255	410	570	21		
	15 020	0,12 - 0,20	0,15 - 0,37	0,50 - 0,80	0,040	0,040			0,25 - 0,35		Al min.0,015	270	450	600	22		
<b>ASTM</b>																	
A 234	WPB	max.0,30	min.0,10	0,29 - 1,06	0,035	0,035	max.0,40	max.0,40	max.0,15	max.0,40	V min.0,08	240	35	415	585	60	30
	WPC	max.0,35	min.0,10	0,29 - 1,06	0,035	0,035	max.0,40	max.0,40	max.0,15	max.0,40	V min.0,08	275	40	485	655	70	30
A 420	WPL 6	max.0,30	0,15 - 0,30	0,60 - 1,35	0,035	0,030	max.0,30	max.0,40	max.0,12	max.0,40	V min.0,05	240	35	415	585	60	30
<b>DIN</b>																	
2609	St 37.0	max.0,17			0,040	0,040						235	350	480	25		
	St 44.0	max.0,21			0,040	0,040						275	420	550	21		
	St 52.0	max.0,22	max.0,55	max.1,60	0,040	0,035					Al min.0,20	355	500	650	21		
	St 35.8	max.0,17	0,10 - 0,35	0,40 - 0,80	0,040	0,040						235	360	480	25		
	15Mo3	0,12 - 0,20	0,10 - 0,35	0,40 - 0,80	0,035	0,035			0,25 - 0,35			270	450	600	22		
	TStE 285	max.0,16	max.0,40	0,60 - 1,40	0,030	0,025	max.0,30	min.0,30	max.0,08		Al min.0,020	285	390	510	24		
	TStE 355	max.0,18	0,10 - 0,50	0,60 - 1,65	0,030	0,025	max.0,30	min.0,30	max.0,08	max.0,20	Al min.0,020	355	490	630	22		
	WStE 355	max.0,20	0,10 - 0,50	0,90 - 1,65	0,030	0,030	max.0,30	min.0,30	max.0,08	max.0,20	Al min.0,020	355	490	630	22		
	StE 290.7	max.0,22	max.0,45	0,50 - 1,10	0,040	0,035						290	420	540	23		
	StE 360.7	max.0,22	max.0,55	0,90 - 1,50	0,040	0,035						360	510	630	20		
<b>BS</b>																	
1965-1	360	max.0,17	0,10 - 0,35	0,30 - 0,80	0,035	0,035					Al max.0,06	235	360	500	25		
<b>NF A</b>																	
49-186	AE 220A	max.0,20	max.0,40	max.0,85	0,045	0,045						220	360	500	23		
<b>EN</b>																	
10253-1	S 235	max.0,16	max.0,35	max.1,20	0,030	0,025						235	360	500	26		
10253-2	P235TR2	max.0,16	max.0,35	max.0,70	0,030	0,025	max.0,30	min.0,30	max.0,08	max.0,30	Al min.0,020	235	360	500	25		
	P265TR2	max.0,20	max.0,40	max.1,40	0,030	0,025	max.0,30	min.0,30	max.0,08	max.0,30	Al min.0,020	265	410	570	21		
	P355N	max.0,20	max.0,50	0,90 - 1,70	0,030	0,025	max.0,30	min.0,50	max.0,08	max.0,30	Nb min.0,05	355	490	650	22		
	P235	max.0,16	max.0,35	max.1,20	0,030	0,025	max.0,30	min.0,30	max.0,08	max.0,30	Al min.0,020	235	360	500	25		
	P265	max.0,20	max.0,40	max.1,40	0,030	0,025	max.0,30	min.0,30	max.0,08	max.0,30	Al min.0,020	265	410	570	21		
	16Mo3	0,12 - 0,20	max.0,35	0,40 - 0,90	0,030	0,025	max.0,30	min.0,30	0,25 - 0,35	max.0,30		280	450	600	22		
	P355NH	max.0,20	max.0,50	0,90 - 1,70	0,030	0,025	max.0,30	min.0,50	max.0,08	max.0,30	Nb min.0,05	355	490	650	22		
	P215	max.0,15	max.0,35	0,40 - 1,20	0,030	0,025	max.0,30	min.0,30	max.0,08	max.0,30	Nb min.0,10	215	360	480	23		
	P355NL1	max.0,18	max.0,50	0,90 - 1,70	0,025	0,020	max.0,30	min.0,50	max.0,08	max.0,30	Nb min.0,05	355	490	650	22		
	L415NE	max.0,21	max.0,45	max.1,60	0,025	0,020	max.0,30	min.0,30	max.0,10	max.0,25	Nb min.0,05	415	520		18		
10025	S355J2G3	max.0,20	max.0,55	max.1,60	0,035	0,035						355	490	630			

### Notes to page 94:

- In standard EN 10253 (fittings) there is possibility to complete preparation of ends for welding also by beveling of outside edge on 30° and inside edge on 18° to axle of fitting (upon agreement only).
- Values are valid for products, where beveling is according standard ANSI B 16-25.
  - The values for beveling of ends according standard API 5L and for pipes according to ASTM A (ASME SA) are identical with standard EN. In case of preparation of inside edge angle can not exceed 7° to longitudinaly axle ( $T \leq 10,5$  mm) and 9,5° to T 10,5 – 14 mm. (upon agreement only).
  - Pipe according to API 5 CT are delivered with square cut plain ends.

### Sulfide Stress Cracking (SSC) Resistant Metallic Materials - Requirements

Material requirements for sulfide stress cracking are specified in american standards, „NACE STANDARD MR“

The NACE MR0175 standard, also known as ISO 15156 (International Standard) was developed for the prevention of sulfide stress cracking due to  $H_2S$  in oil and gas production system.

The NACE MR0103 standard was developed to be a refinery-specific sour service materials standard. The standard provides recommendations on which alloys and materials to use to prevent sulphide stress cracking in an  $H_2S$  containing environment.

Note: acronym “NACE” Has more meanings than one. “NACE” code means “Classification of Economic activities” which in Slovakia was known until now as “OKEC”. In our case “NACE International” is the leading international organization focusing on corrosion of materials. Current name is derived from the acronym of this organization “National Association of Corrosion Engineers”, which was founded in USA to address corrosion protection of tubings and pipes. Specifications of this American organization NACE International THE CORROSION SOCIETY labeled as NACE Standard MR (Standard Material Requirements) are establishing materials suitable to use in environment where there is Hydrogen Sulphide present.

Allowed sizes and shapes tolerances of butt welding elbows

Table 42

Parameter	PN ŽP 42 5760	DIN 2605, DIN 2609	Standards					
			EN 10 253-2	ASME (ANSI) B 16.9				
				in	mm			
<b>Outside diameter</b>	±1,25 % min. ±0,5 mm	±1 % allowed ±0,5 mm	±1 % min. ±0,5 mm	1/2-2 1/2 -0,03 +0,06	21,3-73,0 ±1			
				3-3 1/2 ±0,06	88,9-101,6 ±1			
				4 ±0,06	114,3 -1 +2			
				5-8 -0,06 +0,09	141,3-219,1 -1 +3			
				10-18 -0,12 +0,16	273-457 -3 +4			
				20-24 -0,19 +0,25	508-610 -5 +6			
				26-30 -0,19 +0,25	660-762 -5 +7			
				<b>Inside diameter</b>	min. 80 % of theoretical inside diameter (= D - 2T) d min = 0,8 (D - 2T)			1/2-2 1/2 ±0,03
3-3 1/2 ±0,06	88,9-101,6 ±1,6							
4 ±0,06	114,3 ±1,6							
5-8 ±0,06	141,3-219,1 ±1,6							
10-18 ±0,12	273-457 ±3,2							
20-30 ±0,19	508-762 ±4,8							
<b>Ovality</b>	D > 200 2% (4%)		1,5%					
<b>Wall thickness</b>	-15 % +12,5 % (±17,5 %)	-12,50 % +15 %	D ≤ 610 mm T ≤ 4 mm -12,5 % +20 % T > 4 mm -12,5% +15%					Wall thickness > 87,5 % of nominal wall thickness (-12,5%)
<b>b (K)</b>	31,8-76,1 ±2,5 mm	DN 15 - 65 ±2,5 mm	±7 mm	1/2-24 ±0,25	21,3-600 ±7			
	82,5-114,3 ±3,0 mm	DN 80-100 ±3,0 mm						
	133,0-219,1 ±3,5 mm	DN 125-200 ±3,5 mm						
	D > 220 ±4,0 mm	DN > 250 ±4,0 mm						
<b>2 b</b>	31,8-76,1 ±8 mm	DN 15-65 ±8 mm	±14 mm	1/2-8 ±0,25	21,3-200 ±7			
	82,5-114,3 ±9 mm	DN 80-100 ±9 mm						
	133,0-219,1 ±10 mm	DN 125-200 ±10 mm						
	D > 220 ±14 mm	DN > 250-450 ±14 mm						
<b>Q/P</b>	±4°	±1% of outside diameter or min ±1 mm	±1% of outside diameter or min ±1 mm For EN 10224 Q max 1,6 mm	1/2-4 0,03/0,06	21,3-114,3 1/2			
				5-8 0,06/0,12	141,3-219,1 2/4			
				10-12 0,09/0,19	273-323,8 3/5			
				14-16 0,09/0,25	335,6-406,4 3/7			
				18-24 0,12/0,38	457-610 4/10			
				26-30 0,19/0,38	660-762 5/10			

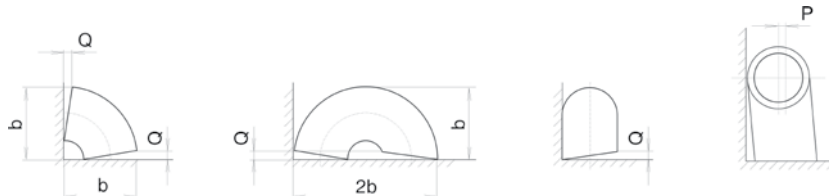



## Steel tube reducers

List of standards for tube reducers

Standards	Dimensional standards	Dimensions	TDC	Steel grade
<b>STN, ČSN</b>	13 2200 13 2380 (13 2385)	Tab. 42	13 2370	11 353 12 021
<b>DIN</b>	2616 - 2		2609 (A) 2609 (F, G)	St 37.0 St 35.8
<b>ISO</b>	3419		3419	
<b>EN</b>	10 253 - 1		10 253 - 1	S 235, S 265

Upon agreement it is possible to deliver reducers made also from other steel (see survey table of butt welding elbows - page 92).

### List of dimensional standards and technical delivery conditions standards

STN, ČSN 13 2200	Steel pipe fittings for butt welding. Construction dimensions.
STN, ČSN 13 2370	Reducers. TDC.
STN, ČSN 13 2380	Reducers Js 20 – Js 350, Jt 40 – Jt 100.
STN, ČSN 13 2385	Reducers DN 20 – DN 500, PN 40 – PN 100.
DIN 2609	Butt welding fittings. TDC.
DIN 2616-2	Reducers. Full correlation of utilization. E
N 10 253-1	Butt-welding pipe fittings. Part 1: Wrought carbon steel for general use and without specific inspection requirements.
ISO 3419	Butt welding fittings wrought carbon and alloy steel.

GOST 17378 Reducers. Dimensions.  
GOST 17380 Reducers. TDC.

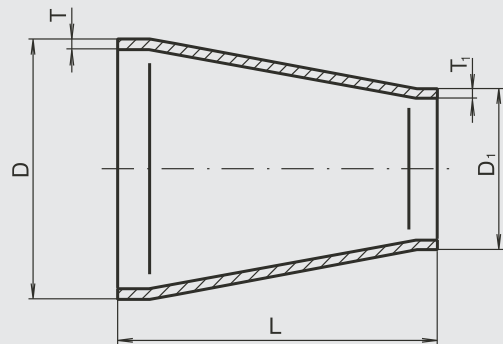

### Dimensions of concentric reducers - type 1

Table 43

Side D				Side D1				Length L [mm]	Theoretical weight [kg]
NPS	DN	D [mm]	T [mm]	NPS1	DN1	D1 [mm]	T1 [mm]		
3/4	20	26,9	2,3	1/2	15	21,3	2,0	38	0,06
1	25	33,7	2,6	3/4	20	26,9	2,3	50	0,10
				1/2	15	21,3	2,0	50	0,10
1 1/4	32	42,4	2,6	1	25	33,7	2,6	50	0,13
				3/4	20	26,9	2,3	50	0,13
				1/2	15	21,3	2,0	50	0,13
1 1/2	40	48,3	2,6	1 1/4	32	42,4	2,6	64	0,19
				1	25	33,7	2,6	64	0,19
				3/4	20	26,9	2,3	64	0,19
				1 1/2	40	48,3	2,6	76	0,30
				1 1/4	32	42,4	2,6	76	0,29
				1	25	33,7	2,6	76	0,28
2	50	60,3	2,9	3/4	20	26,9	2,3	76	0,26
				1 1/2	40	48,3	2,6	76	0,31
				1 1/4	32	42,4	2,6	76	0,31
				1	25	33,7	2,6	76	0,31
				2	50	60,3	2,9	90	0,48
2 1/2	65	76,1	2,9	2	50	60,3	2,9	90	0,48
				1 1/2	40	48,3	2,6	90	0,48
				1 1/4	32	42,4	2,6	90	0,48
				2 1/2	65	76,1	2,9	90	0,61
				2	50	60,3	2,9	90	0,61
				1 1/2	40	48,3	2,6	90	0,61
3	80	88,9	3,2	1 1/4	32	42,4	2,6	90	0,59
				2 1/2	65	76,1	2,9	100	0,98
				2	50	60,3	2,9	100	0,98
				1 1/2	40	48,3	2,6	100	0,98
				1 1/4	32	42,4	2,6	100	0,98
				3	80	88,9	3,2	100	1,00
4	100	114,3	3,6	2 1/2	65	76,1	2,9	100	1,00
				2	50	60,3	2,9	100	1,00
				1 1/2	40	48,3	2,6	100	1,00
				1 1/4	32	42,4	2,6	100	1,00
				3	80	88,9	3,2	100	1,00

## Continuously cast steel blooms

Steel blooms are the starting material for the production of seamless hot finished tubes and pipes. They are also used for the production of other metallurgical semi products by hot forming (rolling, forging, pressing).

### Dimensions and tolerances

#### Dimensions and dimensional tolerances of steel bloom - square cross-section

Table 44

Square side [mm]	Tolerances [mm]	Sidelong max* [mm]	Cross-section area [mm <sup>2</sup> ]	Weight [kg/m]	Edge of the bloom [mm]
125	±3	5	15 600	120,0	R = 3 mm ±1 mm
150	±3	6	22 420	175,5	R = 3,5 mm ±1 mm
160	±3	6	25 600	199,7	R = 4,5 mm ±1 mm
180	±3	7	32 100	252,7	R = 5,5 mm ±1 mm
200	±4	7	39 680	312,0	R = 6,5 mm ±1 mm
205	±4	7	40652	319,5	R = 40 mm ±2 mm
225	±5	9	50 170	394,8	R = 7 mm ±1 mm
280	±6	11	76 662	615,0	R = 7,5 mm ±1 mm

\* Difference of diagonals of square

#### Dimensions and dimensional tolerances of steel bloom - circular cross-section Tabulka 45

Diameter [mm]	Tolerances [mm]	Ovality [mm]	Cross-section area [mm <sup>2</sup> ]	Weight [kg/m]
150	±3	3	17 662	138,5
180	±3	5	25 434	199,6
210	±4	5	34 618	270,0
240	±4	6	45 216	352,7
260	±4	6	53 066	414,0
280	± 6	7	61 575	475,0

### Lengths

The blooms are delivered in lengths of 4 000 – 10 000 mm with length tolerance of +50 mm.

Straightness tolerance - 1% of length

Obliqueness of front side - 5°

### Steel quality

The steel is produced by electric process and is fully killed. The chemical composition of the steel is determined by standards and steel grades for individual groups of tubes. It is also possible to deliver blooms from other steel grades to meet specific customer requirements.

Element content in % of weight																	
	C	Mn	Si	Cr	Mo	Ni	V	S	P	Cu	Sn	Al	Ti	B	Nb	O	N
<b>min</b>	0,05	0,3	0,1	0,05	0,05	max	0	max	max	max	max	0,005					
<b>max</b>	1,2	2,5	1,3	2,5	1,1	3,4	0,8	0,035	0,035	0,40	0,040	0,050	0,050	0,001	0,050	0,035	0,010

Gases volume: O max. 0,0035% (35ppm), H max. 0,0050% (50ppm), N max 0,010% (100 ppm) - according agreement max. 0,008%.

Conversion: a (%) x 10 000 = b (ppm). (But the using of ppm is in system SI non-permissible).

### Heat treatment, delivery condition and surface quality

After casting the blooms are not heat treated, nor is the surface treated. Blooms are delivered according to technical delivery requirements.

### Testing

Blooms are tested according to appropriate standards.

### Marking

Blooms are stamped on their face. Markings include: heat number, steel grade code, stream number. In special cases blooms are marked with colour.

### Laying of blooms

Square cross-section – in layers

Circular cross-section – in special wooden pads or bound with steel strip.

### Certification

Test report certificate in accordance with the specification: DIN 50049, EN 10204 – 3.1 or others.

# ATTACHMENT AND SUPPLEMENTS

## Tube packaging

On request or according to standard tubes and pipes are delivered with ends closed with plastic plugs or caps.

### HOT FINISHED TUBES AND PIPES

The tubes are shipped in round bundles with diameter max. 800 mm, max. mass is 3 500 kg.

On request hexagonal bundles.

#### Standard methods:

The bundle binded by wire

The bundle binded by steel strap

Steel strap underlayered by paper tape (tapaten)

#### Non – standard methods:

The ends of bundle are wrapped in PE-foil or tapaten and foil

### PRECISION COLD DRAWN TUBES

The tubes are shipped in round bundles with diameter max. 800 mm, max. mass is 2 000 – 2 500 kg.

On request hexagonal bundles.

#### Standard methods:

The bundle binded by steel strap

Steel strap underlayered by tapaten

#### Non-standard methods:

The bundle is wrapped in PE-foil

The ends of bundle are wrapped in PE-foil or other material

Wooden mats round the bundle as a mechanical protection

Wooden box- tubes are in box lose or in bundle

Combinations of various types of packaging

### PIPE FITTINGS

Metal boxes

Cardboard boxes on wooden palette

### TUBE SEMIPRODUCTS

#### Standard methods:

Metal boxes (840 x 1 240 x 860 mm)

Hexagonal bundles

Hydraulic tubes are shipped in round bundles with mass max. 2 000 kg and length of 6 m binded by steel strap

#### Packaging according to customer requirements:

Cardboard boxes on wooden palette

Wooden boxes (mass max. 1 000 kg)

Large-volume bags BIG-BAG

Palettes of wooden prisms



## Tests for mechanical and technological properties of tubes

Selection of tests shall be governed by relevant standards that apply to individual products. The values apply for dimension and material condition specified in the standards. Unless otherwise specified, tests relate to samples taken longitudinally

### Mechanical testing

---

#### Tensile test at room temperature (Zugversuch bei Raumtemperatur)

Determined values:

The upper yield strength  $R_{eH}$  or the 0,2% proof strength  $R_{p0,2}$  (MPa)

The tensile strength  $R_m$  (MPa)

Elongation  $A_{min}$  (%)

EN 10002/1 - replaced by EN ISO 6892-1, DIN 50 145, ČSN 42 0310, ASTM A370 (ASME SA 370)

#### Tensile test at elevated temperature (Zugversuch bei erhöhter Temperatur)

Determined values:

The proof strength at the agreed temperature  $R_{p0,2}$  (MPa)

EN 10002-5, DIN 50 145, ČSN 42 0312

#### Hardness test (Härteprüfung) (according to agreement and possibilities)

Detected values:

Brinell: EN 10003, EN ISO 6506, DIN 50 351, ČSN 42 0371, ASTM E 10

Rockwell: EN 10004, EN ISO 6508, DIN 50 103, ASTM E 18

Vickers: EN ISO 6507, DIN 50 133, ASTM E 92, ASTM E 384

Conversion table hardness to R: DIN 50 150

#### Impact test at 20°C (Kerbschlagbiegeversuch bei 20°C)

##### Impact test at low temperatures (Kerb. bei niedrigen Temperaturen)

The possibility of execution of examination is depended on dimensions of tubes

Determined values:

Minimum average absorbed energy  $KV$  (impact energy) (J)

EN ISO 148-1, DIN 50 115, ČSN 42 0381, ASTM A370 (ASME SA 370)

#### Creep testing (Langzeitwarmfestigkeit)

The creep rupture properties shall not be subject to verification, the steels are tested at verification of products technology

Determined values:

The creep proof strength (Zeitdehngrenze)  $R_T(t/A/T)$  is the tension, which in time  $t$  at temperature  $T$  bring about  $A$  % of middle durable relative elongation of length of test specimen.

E.g.  $A = 1\%$ ,  $t = 10\,000$  hours,  $T = 500^\circ\text{C}$  -  $R_T 10\,000/1/500 = 70$  MPa

The creep rupture strength (Zeitstandfestigkeit) -  $R_{mT}(t/T)$  is the tension, at which durable activity at temperature  $T$  is middle time  $t$  until fracture of specimen.

E.g. tension 100 MPa results in the time  $t = 10\,000$  hours and at temperature

$T = 600^\circ\text{C}$  the fracture of component -  $R_{mT} 10\,000/600 = 100$  MPa

Data are presented in annexes of standards and can be used for calculations.

At the present time is used second value and for stability calculations is compared in under creep area with proof strength at elevated temperature. For calculations is used always lower value.

EN ISO 204

EN 10291 +Bbl 1, ČSN/STN 42 0351 (42 0302), ASTM E139

**Fatigue testing** – test is not included in standards for tubes and pipes

## Technological testing (Manipulating tests)

---

When tested in accordance with related standards the test piece shall withstand being tested without cracking. The following tests are made to prove ductility of tubular products :

**Bend test (Biegeversuch)** – (in full size tubular sections).

Test is used for pipe in sizes 2 in. or 65 mm and under. In this test a sufficient length of full size pipe is bent cold through (90°) around a cylindrical mandrel having a diameter e.g. 12 times the nominal diameter of the pipe. EN ISO 8491, ASTM A 370 (A 2,A 2.5), ČSN 420415.3

**Flattening test (Ringfaltversuch)**

The test piece shall be flattened at room temperature between parallel flat platens until the distance between the platens H (in mm) measured under load reaches the value given by the equation in standard. Tested are tubes - D shall be 600 mm and under and with T shall be 15% of D and under. EN ISO 8492, DIN 50 136, ASTM A 370 and standards for tubes and pipes, ČSN 42 0415.4.

**Flaring test (Drift expanding test)/ (Aufweitversuch)**

The test piece shall be expanded by a tapered mandrel, having an included angle of 60° at the option of the manufacturer until the percentage increase in outside diameter shown in tables in standards is reached. D shall be 150 mm and under and T shall be max. 10 mm. EN ISO 8493, DIN 50 135, ASTM A 370, ČSN 42 0415.5.

**Flanging (Flange) test (Bordelversuch)**

The test piece shall have a flange turned over at right angles to the body of the tube to the width required by the applicable material specifications. D max 150 mm, T max. 10 mm. EN ISO 8494, DIN 50 139, ASTM A 370, ČSN 42 0415.6.

**Ring-expanding test (Ringaufdornversuch)**

The test piece shall be expanded with a conical tool until it breaks. The surface outside the fracture zone shall be free from cracks or breaks. D 18-150 mm (114,3 mm), T 2-16 mm (12,5 mm). EN ISO 8495, DIN 50 137, ČSN 42 0415.7.

**Ring tensile test (Ringzugversuch)**

The test piece shall be subjected to strain in the circumferential direction until fracture occurs. After fracture the test pieces shall not show any visible cracks without the use of magnifying aids (excluding the fracture point).

D above 150 mm, d above 100 mm and T 40 mm and under. EN ISO 8496, DIN 50 138.

## Others additional technological tests

---

**Crush test (upsetting test) (Anstauchen test)**

The test piece is placed on end and crushed endwise by hammer or press to the distance prescribed by the applicable material specifications.

**Reverse flattening test (Reversionringfaltversuch)**

For testing of welds of electric welded tubing

**(Transverse guided) Bend test of welds (Biegeprüfungen von Schweissnahten)**

This bend test is used to determine the ductility of fusion welds.

### ISO 377

Steel and steel products - Location and preparation of samples and test pieces for mechanical testing

## Tube suitability for hot dip galvanization

---

All structural steels are possible to hot dip zinc, but quality, appearance and thickness of coating influences the chemical composition of steel (the content of Si + P).

For general structural steels is recommended to keep the content of Si + P in range 0,13 %–0,28 %.

## Carbon equivalent

---

**CEV (IIW)**

Carbon Equivalent Value (CEV) according to the International Institute of Welding (IIW).

$$CE = \%C + \frac{\%Mn}{6} + \left( \frac{\%Cr + \%Mo + \%V}{5} \right) + \left( \frac{\%Cu + \%Ni}{15} \right)$$

## The tightness of tubes under the ASTM (ASME) regulations

Within limits it is necessary to use in preference the methods of NDE (NDT), especially for cold finished tubes. If hydrostatic test is agreed, for the test pressure value calculation is valid:

### ASTM A450 and ASTM A 1016 (Tube)

Minimum hydrostatic test pressure is determined by the following formula:

Inch - Pound units:  $P = 32000 t / D$  (psi) SI units (mm):  $P = 220,6 t / D$  (MPa)

The minimum hydrostatic test pressure need not exceed these values:

D (in., mm)	Pressure P (psi, MPa)
Under 1 (25,4)	1 000 (7)
1- under 1 1/2 (25,4 - under 38,1)	1 500 (10)
1 1/2 - under 2 (38,1 - under 50,8)	2 000 (14)
2 - under 3 (50,8 - under 76,2)	2 500 (17)
3 - under 5 (76,2 - under 127)	3 500 (24)
5 and over (127 and over)	4 500 (31)

The values are valid for ASTM A 450, for ASTM A 1016 is valid value 1000 psi - 7 MPa

Higher pressure according to agreement. The tube wall stress shall be determined by the following equation:

$S = PD / 2t$  (psi, MPa).

(The standards do not specify the amount of tension S as a share of 60% min. yield strength)

### ASTM A 530 and A999 (Pipe)

Each length of pipe shall be tested to a hydrostatic pressure which will produce in the pipe wall a stress not less than 60% of the minimum specified yield strength for C-steel pipe:

$P = 2 St / D$  (inch or mm, psi or MPa)  $S = PD / 2t$

The minimum hydrostatic test pressure need not exceed 2500 psi (17,0 MPa) for pipe 3,5 in or 2800 psi (19,0 MPa) for pipe over 3,5 in (88,9 mm)

Upon agreement it is possible to test with higher pressure too.

The values of pressures are also in tables of relevant standards TDC - ASTM A.

For comparison - pressure according to formulas based on EN is in bars.

## Definition of status and nomenclature of heat treatment

### Delivery conditions and heat treatment according to DIN and EN

Precision tubes are delivered in following conditions (first symbol lists previous designation, the new one according to EN is in brackets):

<b>+C (BK)</b>	<b>Cold finished/hard</b> (cold finished as drawn). No heat treatment after last cold forming process.
<b>+LC (BKW)</b>	<b>Cold finished/soft</b> (lightly cold worked). After last heat treatment there is a light finishing pass (cold drawing).
<b>+SR (BKS)</b>	<b>Cold finished/stress relieve annealed.</b> After the final cold forming process the tubes are stress relieve annealed.
<b>+A (GBK)</b>	<b>Annealed.</b> After the final cold forming process the tubes are annealed in a controlled atmosphere.
<b>+N (NBK)</b>	<b>Normalized.</b> After the final cold forming process the tubes are annealed above the upper transformation point in a controlled atmosphere.

### Material condition designation depending on heat treatment according to ČSN and STN (first supplementary number behind steel grade):

- 0 - without heat treatment
- 1 - normalized
- 2 - annealed (kind stated)
- 3 - soft annealed
- 4 - quenched and tempered
- 5 - normalised and tempered
- 6 - heat treatment with the object of achieving a minimum tensile within a specified range
- 7 - heat treatment with the object of achieving a average tensile within a specified range
- 8 - heat treatment with the object of achieving a maximum tensile within a specified range
- 9 - specific (upon agreement)

### Steel condition designation according to ASTM A519:

- CW - Cold Worked
- A - Annealed
- N - Normalized
- SR - Stress Relieved or Finished Annealed
- QT - Quenched and Tempered



## Steel designation according to EN

### Designation of steels for construction and general use

S – structural steel

235 – minimum yield strength in N/mm<sup>2</sup>

Signs at the end of steel designation – additional symbols for steel names

• non-alloy steel

J – impact test, min. average absorbed energy KV – 27J

R – room temperature

0 – temperature 0°C

2 – temperature -20°C

H – hollow section

• fine grain steel (ferritic grain size equal to or finer than 6)

basic series                    N – normalized structure

H – hollow section

low temperature series    N – normalized structure

L – low temperature series

H – hollow section

Fine grain structural steel designation according to DIN 17124

StE        – basic series (-20 °C)

TStE      – deep-drawing series with minimum absorbed energy at temperature of -50 °C

EStE      – deep-drawing series with minimum absorbed energy at temperature of -60 °C

255        – minimum yield strength in N/mm<sup>2</sup>

### Designation of steels for machine parts

• **steel for tubes for mechanical treatment:**

steel E355 + AR, E 355 + N

E – steel for machine parts, 355 – minimum yield strength in N/mm<sup>2</sup>, +AR – heat treatment is not required,

+N – normalising annealed or formed

steel 20MnV6

steel designated by chemical composition – guaranteed mean C content 0,20%, guaranteed content Mn and V

+AR – heat treatment is not required, +N – normalising annealed or formed

• **steel for machine parts:**

steel without heat treatment after mechanical treatment

non-alloy steel E 235, E275, E315, E355

Condition +AR or +N

steel with specific impact qualities (fine-grain) E275K2, E355K2

K2 – guaranteed characteristic of impact energy 40 J (K) by temperature -20 °C

steel with heat treatment after mechanical treatment

steel C22E

C – steel with carbon content 0,22%, E – reference to maximum checked content of S and P

steel 38Mn6

– guaranteed mean C content and guaranteed Mn content

## Boiler steel designation

- base non-alloy steel
  - P – steel for pressure equipments
  - 235 – minimum yield strength in N/mm<sup>2</sup>
  - G – general characteristic, devise to second symbol
  - H – high temperature
- alloy steel
  - steel designated according to chemical composition (PED 97/23EC and AD 2000 - W4)

## Designation of steel for low temperature

- P – steel for pressure equipments
  - 215 – minimum yield strength in N/mm<sup>2</sup>
  - N – normalized or normalising formed
  - L – low temperature steel
- Alloy steels are designated according to the chemical composition (PED 97/23EC and AD 2000 - W4)

## Designation of steels from fine grain steel

- P – steel for pressure equipments
- 355 – minimum yield strength in N/mm<sup>2</sup>
- N – normalized or normalising formed
- NH – high temperature steel
- NL1 – low temperature steel
- NL2 – special low temperature steel (PED 97/23EC and AD 2000 - W4)

## Designation of steels for elevated temperature

- P – steel for pressure equipments
- 235 – minimum yield strength in N/mm<sup>2</sup>
- T – steel for tubes
- R – room temperature
- 1, 2 – group of quality
- TR 1 – Fluid Transportation - General Purposes (see page 52)
- TR 2 – Piping and Pressure Purposes (PED 97/23EC and AD 2000 - W4)

## Conversion table of steel parameters

US units	SI	SI	US units
1 inch	25,4 mm	1 mm	0.03937 inch
12 inches = 1 foot	304,8 mm	1 m	3.2808 feet
1 sq inch	645 mm <sup>2</sup>	1 mm <sup>2</sup>	0.00155 sq inch
1 sq foot	0,093 m <sup>2</sup>	1 m <sup>2</sup>	10.753 sq feet
1 cubic foot	0,02831685 m <sup>3</sup>	1 m <sup>3</sup>	35.31 cubic feet
1 pound (1lb)	0,453592 kg	1 kg	2.20462 lbs
1 short ton (US)	0,907185 metric t	1 metric t	1,10231 short ton
1 long ton (UK)	1,01605 metric t	1 metric t	0,9842 long ton
1 ksi	6,894757 Mpa	1 Mpa	0,145038 ksi

Units: inch (in)  
foot (ft)  
pound (lb)

Temperature: °C = 5/9 (°F – 32)  
°F = 9/5 °C + 32

Conversion of weight to length – C-steel:

Dimensions in mm: 0,0246615 (D – T).T (kg/m)

Dimensions in inch: 10,68142 (D – T).T (lbs/ft)

Weight conversion: kg/m = 1,48816 lb/ft

lb/ft = 0,67197 kg/m

Pressure conversion:

1 Pa = 1 N/m<sup>2</sup>

1 MPa = 1 N/mm<sup>2</sup>

1 MPa = 10,1972 at

1 MPa = 10<sup>6</sup> Pa = 10 bar

1 at = 1 kp/cm<sup>2</sup> (old unit)

1 at = 0,09806 MPa

1 at = 0,98066 bar

1 bar = 1,01972 at (tech)

1 bar = 100 000 Pa (100 kPa)

1 bar = 14,504 psi

1 psi (pound per square inch) = 1 lb/in<sup>2</sup>

1 psi = 0,006894757 MPa (6 895 kPa)

1 psi = 0,06894 bar (0,070307 at)

1 ksi = 1 000 psi = 6,895 (6,9) MPa

# Indicative comparison of steels

## Steels for alloy treatment and cementation - carbon, Type C according to EN

Table 46

Steel	EN		DIN			BS		NFA		UNI	CSN,STN		GOST		PN-H		ASTM		JIS	
	W.Nr.	Standard	Steel	W.Nr.	Standard	Steel	Standard	Steel	Standard	Steel	Steel	Standard	Steel	Standard	Steel	Standard	Steel	Standard	Steel	Standard
-	-	-	St30Si	1.0211	2391-2	-	-	-	-	-	-	-	-	-	-	-	1008	A519	-	-
-	-	-	-	-	-	-	-	-	-	-	-	-	-	-	-	-	1008	A513	-	-
-	-	-	-	-	-	-	-	-	-	-	-	-	-	-	-	-	1008	A512	-	-
-	-	-	C10	1.0301	17210	045M10	970	XC 10	35-551	C10	-	10	1050	-	-	-	1010	A519	STKM11A	G3445
-	-	-	C10	1.0301	17210	-	-	-	-	-	-	-	-	-	-	-	1010	A513	STKM11A	G3445
-	-	-	C10	1.0301	17210	-	-	-	-	-	-	-	-	-	-	-	1010	A512	STKM11A	G3445
C10E	1.1121	10084	Ck10	1.1121	17210	040A10	970	XC 10	35-551	C 10	12 010	10	1050	10	84019	-	1010	A519	STKM11A	G3445
C10E	1.1121	10084	Ck10	1.1121	17210	-	-	-	-	-	-	-	-	-	-	-	1010	A513	STKM11A	G3445
C10E	1.1121	10084	Ck10	1.1121	17210	-	-	-	-	-	-	-	-	-	-	-	1010	A512	STKM11A	G3445
C10E	1.1121	10297-1	Ck10	1.1121	17210	-	-	-	-	-	-	-	-	-	-	-	1010	A519	STKM11A	G3445
C10E	1.1121	10297-1	Ck10	1.1121	17210	-	-	-	-	-	-	-	-	-	-	-	1010	A513	STKM11A	G3445
C10E	1.1121	10297-1	Ck10	1.1121	17210	-	-	-	-	-	-	-	-	-	-	-	1010	A512	STKM11A	G3445
C10R	1.1207	10084	-	-	-	-	-	-	-	-	-	-	-	-	-	-	1010	A519	STKM11A	G3445
C10R	1.1207	10084	-	-	-	-	-	-	-	-	-	-	-	-	-	-	1010	A513	STKM11A	G3445
C10R	1.1207	10084	-	-	-	-	-	-	-	-	-	-	-	-	-	-	1010	A512	STKM11A	G3445
-	-	-	-	-	-	-	-	-	-	-	-	-	-	-	-	-	MT1010	A519	-	-
-	-	-	-	-	-	-	-	-	-	-	-	-	-	-	-	-	MT1010	A513	-	-
-	-	-	-	-	-	-	-	-	-	-	-	-	-	-	-	-	MT1010	A512	-	-
-	-	-	-	-	-	-	-	-	-	-	-	-	-	-	-	-	1012	A519	-	-
-	-	-	-	-	-	-	-	-	-	-	-	-	-	-	-	-	1012	A513	-	-
-	-	-	-	-	-	-	-	-	-	-	-	-	-	-	-	-	1012	A512	-	-
-	-	-	C15	1.0401	17210	080M15	970	XC 15	35-551	C 15	-	-	-	-	-	-	1015	A519	-	-
-	-	-	C15	1.0401	17210	-	-	-	-	-	-	-	-	-	-	-	1015	A513	-	-
-	-	-	C15	1.0401	17210	-	-	-	-	-	-	-	-	-	-	-	1015	A512	-	-
C15E	1.1141	10084	Ck15	1.1141	17210	080M15	970	XC 15	35-551	C 15	12 023	15	1050	-	-	-	1015	A519	S15CK	G 4051
C15E	1.1141	10084	Ck15	1.1141	17210	-	-	-	-	-	-	-	-	-	-	-	1015	A513	-	-
C15E	1.1141	10084	Ck15	1.1141	17210	-	-	-	-	-	-	-	-	-	-	-	1015	A512	-	-
C15E	1.1141	10297-1	Ck15	1.1141	17210	-	-	-	-	-	-	-	-	-	-	-	1015	A519	-	-
C15E	1.1141	10297-1	Ck15	1.1141	17210	-	-	-	-	-	-	-	-	-	-	-	1015	A513	-	-
C15E	1.1141	10297-1	Ck15	1.1141	17210	-	-	-	-	-	-	-	-	-	-	-	1015	A512	-	-
C15R	1.1140	10084	Cm15	1.1140	17210	-	-	-	-	-	-	-	-	-	-	-	1015	A519	-	-
C15R	1.1140	10084	Cm15	1.1140	17210	-	-	-	-	-	-	-	-	-	-	-	1015	A513	-	-
C15R	1.1140	10084	Cm15	1.1140	17210	-	-	-	-	-	-	-	-	-	-	-	1015	A512	-	-
C15R	1.1140	10297-1	Cm15	1.1140	17210	-	-	-	-	-	-	-	-	-	-	-	1015	A519	-	-
C15R	1.1140	10297-1	Cm15	1.1140	17210	-	-	-	-	-	-	-	-	-	-	-	1015	A513	-	-
C15R	1.1140	10297-1	Cm15	1.1140	17210	-	-	-	-	-	-	-	-	-	-	-	1015	A512	-	-
-	-	-	-	-	-	-	-	-	-	-	-	-	-	-	-	-	MT1015	A519	-	-
-	-	-	-	-	-	-	-	-	-	-	-	-	-	-	-	-	MT1015	A513	-	-
-	-	-	-	-	-	-	-	-	-	-	-	-	-	-	-	-	MT1015	A512	-	-
-	-	-	-	-	-	-	-	-	-	-	-	-	-	-	-	-	MTX1015	A519	-	-
-	-	-	-	-	-	-	-	-	-	-	-	-	-	-	-	-	MTX1015	A513	-	-
-	-	-	-	-	-	-	-	-	-	-	-	-	-	-	-	-	MTX1015	A512	-	-
C16E	1.1148	10084	-	-	-	-	-	-	-	-	-	-	-	-	-	-	1016	A519	-	-
C16E	1.1148	10084	-	-	-	-	-	-	-	-	-	-	-	-	-	-	1016	A513	-	-
C16E	1.1148	10084	-	-	-	-	-	-	-	-	-	-	-	-	-	-	1016	A512	-	-
C16R	1.1208	10084	-	-	-	-	-	-	-	-	-	-	-	-	-	-	1016	A519	-	-
C16R	1.1208	10084	-	-	-	-	-	-	-	-	-	-	-	-	-	-	1016	A513	-	-
C16R	1.1208	10084	-	-	-	-	-	-	-	-	-	-	-	-	-	-	1016	A512	-	-
-	-	-	-	-	-	-	-	-	-	-	-	-	-	-	-	-	1017	A519	-	-
-	-	-	-	-	-	-	-	-	-	-	-	-	-	-	-	-	1017	A513	-	-
-	-	-	-	-	-	-	-	-	-	-	-	-	-	-	-	-	1018	A519	STKM12A	G3445
-	-	-	-	-	-	-	-	-	-	-	-	-	-	-	-	-	1018	A513	STKM12A	G3445
-	-	-	-	-	-	-	-	-	-	-	-	-	-	-	-	-	1018	A512	STKM12A	G3445
-	-	-	-	-	-	-	-	-	-	-	-	-	-	-	-	-	1019	A519	-	-
-	-	-	-	-	-	-	-	-	-	-	-	-	-	-	-	-	1019	A513	-	-
-	-	-	-	-	-	-	-	-	-	-	-	-	-	-	-	-	1019	A512	-	-
-	-	-	-	-	-	-	-	-	-	-	-	-	-	-	-	-	1020	A519	-	-
-	-	-	-	-	-	-	-	-	-	-	-	-	-	-	-	-	1020	A513	-	-
-	-	-	-	-	-	-	-	-	-	-	-	-	-	-	-	-	1020	A512	-	-
-	-	-	-	-	-	-	-	-	-	-	-	-	-	-	-	-	1021	A519	-	-
-	-	-	-	-	-	-	-	-	-	-	-	-	-	-	-	-	1021	A513	-	-
-	-	-	-	-	-	-	-	-	-	-	-	-	-	-	-	-	1021	A512	-	-
-	-	-	C22	1.0402	17200	040A20	970	1C22	35-552	C 20	12 024	20	1050	-	-	-	1022	A519	S22C	G 4051
-	-	-	C22	1.0402	17204	-	-	-	-	-	-	-	-	-	-	-	1022	A513	-	-
C22E	1.1151	10297-1	Ck22	1.1151	17200	070M20	970	XC18	35-552	C20	12024	20	1050	20	84019	-	1022	A519	S20C	G 4051
C22E	1.1151	10297-1	Ck22	1.1151	17204	-	-	-	-	-	-	-	-	-	-	-	1022	A519	-	-
C22E	1.1151	10083-2	Ck22	1.1151	17200	-	-	-	-	-	-	-	-	-	-	-	1022	A513	-	-
C22E	1.1151	10297-1	Ck22	1.1151	17204	-	-	-	-	-	-	-	-	-	-	-	1022	A519	-	-
C22E	1.1151	10083-2	Ck22	1.1151	17200	-	-	-	-	-	-	-	-	-	-	-	1022	A513	-	-
C22E	1.1151	10083-2	Ck22	1.1151	17204	-	-	-	-	-	-	-	-	-	-	-	1022	A513	-	-
C22R	1.1149	10083-2	Cm22	1.1149	17200	-	-	-	-	-	-	-	-	-	-	-	1022	A519	-	-
C22R	1.1149	10083-2	Cm22	1.1149	17204	-	-	-	-	-	-	-	-	-	-	-	1022	A513	-	-
-	-	-	-	-	-	-	-	-	-	-	-	-	-	-	-	-	MT1020	A519	-	-
-	-	-	-	-	-	-	-	-	-	-	-	-	-	-	-	-	MT1020	A513	-	-
-	-	-	-	-	-	-	-	-	-	-	-	-	-	-	-	-	MT1020	A512	-	-
-	-	-	-	-	-	-	-	-	-	-	-	-	-	-	-	-	MTX1020	A519	STKM13A	G3445



EN			DIN			BS		NFA		UNI	ČSN,STN	GOST		PN-H		ASTM		JIS		
Steel	W.Nr.	Standard	Steel	W.Nr.	Standard	Steel	Standard	Steel	Standard	Steel	Steel	Steel	Standard	Steel	Standard	Steel	Standard	Steel	Standard	
-	-	-	-	-	-	-	-	-	-	-	-	-	-	-	-	-	MTX1020	A513	STKM13A	G3445
-	-	-	-	-	-	-	-	-	-	-	-	-	-	-	-	-	MTX1020	A512	STKM13A	G3445
-	-	-	C25	1.0406	17200	070M26	970	1C25	35-552	C25	12030	-	-	-	-	-	1025	A519	-	-
-	-	-	C25	1.0406	17200	-	-	-	-	-	-	-	-	-	-	-	1025	A513	-	-
-	-	-	C25	1.0406	17200	-	-	-	-	-	-	-	-	-	-	-	1025	A512	-	-
C25	1.0406	10083-2	C25	1.0406	17200	-	-	-	-	-	-	-	-	-	-	-	1025	A519	S25C	G 4051
C25E	1.1158	10083-2	Ck25	1.1158	17200	070M26	970	XC25	35-552	C25	12030	25	1050	-	-	-	1025	A519	-	-
C25E	1.1158	10083-2	Ck25	1.1158	17200	-	-	-	-	-	-	-	-	-	-	-	1025	A513	-	-
C25E	1.1158	10083-2	Ck25	1.1158	17200	-	-	-	-	-	-	-	-	-	-	-	1025	A512	-	-
C25R	1.1163	10083-2	Cm25	1.1163	17200	-	-	-	-	-	-	-	-	-	-	-	1025	A519	-	-
C25R	1.1163	10083-2	Cm25	1.1163	17200	-	-	-	-	-	-	-	-	-	-	-	1025	A513	-	-
C25R	1.1163	10083-2	Cm25	1.1163	17200	-	-	-	-	-	-	-	-	-	-	-	1025	A512	-	-
-	-	-	-	-	-	-	-	-	-	-	-	-	-	-	-	-	1026	A519	STKM14A	G3445
-	-	-	-	-	-	-	-	-	-	-	-	-	-	-	-	-	1026	A513	STKM14A	G3445
-	-	-	-	-	-	-	-	-	-	-	-	-	-	-	-	-	1026	A512	STKM14A	G3445
-	-	-	-	-	-	-	-	-	-	-	-	-	-	-	-	-	1027	A513	-	-
-	-	-	C30	1.0528	17200	-	-	-	-	-	12031	-	-	-	-	-	1030	A519	-	-
-	-	-	C30	1.0528	17200	-	-	-	-	-	-	-	-	-	-	-	1030	A513	-	-
C30	1.0528	10083-2	C30	1.0528	17200	-	-	-	-	-	-	-	-	-	-	-	1030	A512	-	-
C30E	1.1178	10083-2	Ck30	1.1178	17200	080M30	970	XC32	35-552	C30	12031	-	-	-	-	-	1030	A519	S30CM	G 4051
C30E	1.1178	10083-2	Ck30	1.1178	17200	-	-	-	-	-	-	-	-	-	-	-	1030	A513	-	-
C30E	1.1178	10083-2	Ck30	1.1178	17200	-	-	-	-	-	-	-	-	-	-	-	1030	A512	-	-
C30R	1.1179	10083-2	Cm30	1.1179	17200	-	-	-	-	-	-	-	-	-	-	-	1030	A519	-	-
C30R	1.1179	10083-2	Cm30	1.1179	17200	-	-	-	-	-	-	-	-	-	-	-	1030	A513	-	-
C30R	1.1179	10083-2	Cm30	1.1179	17200	-	-	-	-	-	-	-	-	-	-	-	1030	A512	-	-
-	-	-	-	-	-	-	-	-	-	-	-	-	-	-	-	-	1033	A513	-	-
C35	1.0501	10083-2	C35	1.0501	17200	080M36	970	1C35	35-552	C35	12 040	35	1050	-	-	-	1035	A519	STKM15A	G3445
C35	1.0501	10083-2	C35	1.0501	17204	-	-	-	-	-	-	-	-	-	-	-	1035	A519	STKM15A	G3445
C35	1.0501	10083-2	C35	1.0501	17200	-	-	-	-	-	-	-	-	-	-	-	1035	A513	STKM15A	G3445
C35	1.0501	10083-2	C35	1.0501	17204	-	-	-	-	-	-	-	-	-	-	-	1035	A513	STKM15A	G3445
C35	1.0501	10083-2	C35	1.0501	17200	-	-	-	-	-	-	-	-	-	-	-	1035	A512	STKM15A	G3445
C35	1.0501	10083-2	C35	1.0501	17204	-	-	-	-	-	-	-	-	-	-	-	1035	A512	STKM15A	G3445
C35E	1.1181	10297-1	Ck35	1.1181	17204	CFS6	6323-4	XC38H1	35-552	C35	12040	35	1050	35	84019	1035	A519	STKM15A	G3445	
C35E	1.1181	10297-1	Ck35	1.1181	17204	CFS6	6323-4	-	-	-	12040	35	1050	35	84019	1035	A513	STKM15A	G3445	
C35E	1.1181	10297-1	Ck35	1.1181	17204	CFS6	6323-4	-	-	-	12040	35	1050	35	84019	1035	A512	STKM15A	G3445	
C35E	1.1181	10083-2	Ck35	1.1181	17200	CFS6	6323-4	-	-	-	12040	35	1050	35	84019	1035	A519	STKM15A	G3445	
C35E	1.1181	10083-2	Ck35	1.1181	17200	CFS6	6323-4	-	-	-	12040	35	1050	35	84019	1035	A513	STKM15A	G3445	
C35E	1.1181	10083-2	Ck35	1.1181	17200	CFS6	6323-4	-	-	-	12040	35	1050	35	84019	1035	A512	STKM15A	G3445	
C35R	1.1180	10083-2	Cm35	1.1180	17200	-	-	-	-	-	-	-	-	R55	84023	1035	A519	STKM16A	G3445	
C35R	1.1180	10083-2	Cm35	1.1180	17204	-	-	-	-	-	-	-	-	R55	84023	1035	A519	STKM16A	G3445	
C35R	1.1180	10083-2	Cm35	1.1180	17200	-	-	-	-	-	-	-	-	R55	84023	1035	A513	STKM16A	G3445	
C35R	1.1180	10083-2	Cm35	1.1180	17204	-	-	-	-	-	-	-	-	R55	84023	1035	A513	STKM16A	G3445	
C35R	1.1180	10083-2	Cm35	1.1180	17200	-	-	-	-	-	-	-	-	R55	84023	1035	A512	STKM16A	G3445	
C35R	1.1180	10083-2	Cm35	1.1180	17204	-	-	-	-	-	-	-	-	R55	84023	1035	A512	STKM16A	G3445	
C40	1.0511	10083-2	C40	1.0511	17200	080M40	970	1C40	35-552	C40	12041	-	-	-	-	-	1040	A519	-	-
C40	1.0511	10083-2	C40	1.0511	17200	-	-	-	-	-	-	-	-	-	-	-	1040	A513	-	-
C40E	1.1186	10083-2	Ck40	1.1186	17200	080M40	970	XC42H1	35-552	C40	12041	40	1050	-	-	-	1040	A519	S40C	G 4051
C40E	1.1186	10083-2	Ck40	1.1186	17200	-	-	-	-	-	-	-	-	-	-	-	1040	A513	-	-
C40R	1.1189	10083-2	Cm40	1.1189	17200	-	-	-	-	-	-	-	-	-	-	-	1040	A519	-	-
C40R	1.1189	10083-2	Cm40	1.1189	17200	-	-	-	-	-	-	-	-	-	-	-	1040	A513	-	-
C45	1.0503	10083-2	C45	1.0503	17200	080M46	970	1C45	35-552	C45	12050	45	1050	-	-	-	1045	A519	S45C	G4051
C45	1.0503	10083-2	C45	1.0503	17204	-	-	-	-	-	-	-	-	-	-	-	1045	A519	-	-
C45E	1.1191	10297-1	Ck45	1.1191	17200	CFS8	6323-4	XC48H1	35-552	C45	12050	45	1050	45	84019	1045	A519	S45C	G 4051	
C45E	1.1191	10297-1	Ck45	1.1191	17204	CFS8	6323-4	-	-	-	12050	45	1050	45	84019	1045	A519	-	-	
C45E	1.1191	10083-2	Ck45	1.1191	17200	CFS8	6323-4	-	-	-	12050	45	1050	45	84019	1045	A519	-	-	
C45E	1.1191	10083-2	Ck45	1.1191	17204	CFS8	6323-4	-	-	-	12050	45	1050	45	84019	1045	A519	-	-	
C45R	1.1201	10083-2	Cm45	1.1201	17200	-	-	-	-	-	-	-	-	R65	84023	1045	A519	STKM17A	G3445	
C45R	1.1201	10083-2	Cm45	1.1201	17204	-	-	-	-	-	-	-	-	R65	84023	1045	A519	STKM17A	G3445	
-	-	-	-	-	-	-	-	-	-	-	-	-	-	-	-	-	1545	A519	-	-
-	-	-	C50	1.0540	17200	-	-	1C50	35-552	C50	12051	-	-	-	-	-	1050	A519	-	-
-	-	-	C50	1.0540	17200	-	-	-	-	-	-	-	-	-	-	-	1050	A513	-	-
C50E	1.1206	10083-2	Ck50	1.1206	17200	080M50	970	XC50H1	35-552	C50	12050	50	1050	-	-	-	1050	A519	-	-
C50E	1.1206	10083-2	Ck50	1.1206	17200	-	-	-	-	-	-	-	-	-	-	-	1050	A513	-	-
C50R	1.1241	10083-2	Cm50	1.1241	17200	-	-	-	-	-	-	-	-	-	-	-	1050	A519	-	-
C50R	1.1241	10083-2	Cm50	1.1241	17200	-	-	-	-	-	-	-	-	-	-	-	1050	A513	-	-
C55	1.0535	10083-2	C55	1.0535	17200	070M55	970	1C55	35-552	C55	12060	55	1050	-	-	-	1055	A519	S55C	G 4051
C55	1.0535	10083-2	C55	1.0535	17204	-	-	-	-	-	-	-	-	-	-	-	-	-	-	-
C55E	1.1203	10083-2	Ck55	1.1203	17200	070M55	970	XC55H1	35-552	C55	12060	55	1050	55	84019	1055	A519	S55C	G 4051	
C55E	1.1203																			

Steels for tubes for machine parts – carbon, Type E according to EN

Table 47

Steel	EN		DIN			BS		NFA		UNI		CSN,STN		GOST		PN-H		ASTM		JIS		
	W.Nr.	Standard	Steel	W.Nr.	Standard	Steel	Standard	Steel	Standard	Steel	Standard	Steel	Standard	Steel	Standard	Steel	Standard	Steel	Standard	Steel	Standard	
E155	1.0033	10296-1	-	-	-	-	-	-	-	Fe 280	7945	-	-	-	-	-	-	-	-	-	-	
E155	1.0033	10305-2	-	-	-	CEW1	6323-6	-	-	Fe280	7946	-	-	-	-	08XA	84023	-	-	STKM11A	G 3445	
E155	1.0033	10305-3	-	-	-	ERW1	6323-5	-	-	Fe280	7947	-	-	-	-	-	-	-	-	-	-	
E155	1.0033	10305-5	-	-	-	-	-	-	-	-	-	-	-	-	-	-	-	-	-	-	-	
E155	1.0033	10305-6	-	-	-	-	-	-	-	-	-	-	-	-	-	-	-	-	-	-	-	
E190	1.0031	10296-1	-	-	-	-	-	-	-	-	-	-	-	-	-	-	-	-	-	-	-	
E190	1.0031	10305-3	-	-	-	-	-	-	-	-	-	11320	42 0142	-	-	-	-	-	-	-	-	
E190	1.0031	10305-5	St33	1.0035	2395-2	-	-	-	-	-	-	-	-	-	-	-	-	-	-	-	-	
E195	1.0034	10296-1	-	-	-	-	-	-	-	Fe320	7945	-	-	-	-	-	-	-	-	-	-	
E195	1.0034	10305-2	RSt34-2	1.0034	2393-2	CEW2	6323-6	ES185	49-646	Fe320	7946	11343	42 0142	-	-	12X	84023	-	-	-	-	
E195	1.0034	10305-3	RSt34-2	1.0034	2394-2	ERW2	6323-5	ES185	49-646	Fe320	7947	11343	42 0142	-	-	12X	84023	-	-	-	-	
E195	1.0034	10305-5	-	-	-	-	-	-	-	Fe 320	7287	-	-	-	-	-	-	-	-	-	-	
E195	1.0034	10305-6	-	-	-	-	-	-	-	-	-	-	-	-	-	-	-	-	-	-	-	
E215	1.0212	10305-1	St30A1	1.0212	2391-2	-	-	-	-	-	-	-	-	-	-	-	-	-	-	-	-	
E215	1.0212	10305-4	St30A1	1.0212	2391-2	-	-	-	-	-	-	-	-	-	-	-	-	-	-	-	-	
E220	1.0215	10296-1	-	-	-	-	-	-	-	-	-	-	-	-	-	-	-	-	-	-	-	
E220	1.0215	10305-3	-	-	-	-	-	ES200	49-646	-	-	-	-	-	-	-	-	-	-	-	-	
E220	1.0215	10305-5	-	-	-	-	-	-	-	-	-	-	-	-	-	-	-	-	-	-	-	
E235	1.0308	10296-1	-	-	-	-	-	-	-	-	-	-	-	-	-	-	-	-	-	-	-	
E235	1.0308	10297-1	-	-	-	HFS3	6323-3	TU37-b	49-311	Fe360	7729	-	-	-	-	-	-	-	-	STKM12A	G 3445	
E235	1.0308	10305-1	St35	1.0308	2391-2	CFS3	6323-4	TU37-b	49-310	Fe360	7945	11353	42 0250	10	1050	10	84019	Gr.A	A53	-	-	
E235	1.0308	10305-2	RSt37-2	1.0038	2393-2	CEW3	6323-6	ES235	49-646	Fe360	7946	-	-	-	-	R35	84023	-	-	-	-	
E235	1.0308	10305-3	RSt37-2	1.0038	2394-2	ERW3	6323-5	-	-	Fe360	7947	11373	42 0142	10	10707	St3x	84020	-	-	-	-	
E235	1.0308	10305-4	-	-	-	-	-	TU37-b	49-330	-	-	-	-	-	-	-	-	A822	A822	-	-	
E235	1.0308	10305-5	RSt37-2	1.0038	2395-2	-	-	-	-	-	-	-	-	-	-	-	-	-	-	-	-	
E235	1.0308	10305-6	-	-	-	-	-	-	-	-	-	-	-	-	-	-	-	-	-	-	-	
-	-	-	-	-	-	-	-	-	-	Fe35-1	663	-	-	-	-	-	-	-	-	-	-	
-	-	-	-	-	-	-	-	-	-	Fe35-2	663	-	-	-	-	-	-	-	-	-	-	
-	-	-	-	-	-	-	-	-	-	Fe360	6363	-	-	-	-	-	-	-	-	-	-	
E255	-	10305-1	-	-	-	CFS4	6323-4	TU42-b	49-310	-	-	-	-	-	-	-	-	-	-	-	-	
E255	-	10305-1	-	-	-	CFS4	6323-4	TU42BT	49-330	-	-	-	-	-	-	-	-	-	-	-	-	
E255	-	10305-1	-	-	-	HFS4	6323-3	-	-	-	-	-	-	-	-	-	-	-	-	-	-	
E260	1.0220	10296-1	-	-	-	-	-	-	-	-	-	-	-	-	-	-	-	-	-	-	-	
E260	1.0220	10305-3	-	-	-	-	-	ES250	49-646	-	-	-	-	-	-	-	-	-	-	-	-	
E260	1.0220	10305-5	-	-	-	-	-	-	-	-	-	-	-	-	-	-	-	-	-	-	-	
E275	1.0225	10296-1	-	-	-	-	-	-	-	-	-	-	-	-	-	-	-	-	-	-	-	
E275	1.0225	10297-1	-	-	-	-	-	-	-	Fe430	7729	-	-	-	-	-	-	-	-	-	-	
-	-	-	St45	1.0408	2391-2	CFS4	6323-4	TU42-b	49-310	Fe410	7945	11453	42 0260	20	1050	20	84019	Gr.B	A53	STKM18A	G 3445	
E275	1.0225	10305-2	St44-2	1.0044	2393-2	CEW4	6323-6	ES275	49-646	Fe410	7946	-	-	-	-	-	-	-	-	-	-	
E275	1.0225	10305-3	St44-2	1.0044	2394-2	ERW4	6323-5	ES275	49-646	Fe410	7947	-	-	20	10707	R45	84023	-	-	-	-	
E275	1.0225	10305-5	-	-	-	-	-	-	-	-	-	-	-	-	-	-	-	-	-	-	-	
E275	1.0225	10305-6	-	-	-	-	-	-	-	-	-	-	-	-	-	-	-	-	-	-	-	
-	-	-	-	-	-	-	-	-	-	Fe45-1	663	-	-	-	-	-	-	-	-	-	-	
-	-	-	-	-	-	-	-	-	-	Fe45-2	663	-	-	-	-	-	-	-	-	-	-	
-	-	-	-	-	-	-	-	-	-	Fe410	6363	-	-	-	-	-	-	-	-	-	-	
E275K2	1.0456	10296-1	-	-	-	-	-	-	-	-	-	-	-	-	-	-	-	-	-	-	-	
E275K2	1.0456	10297-1	-	-	-	-	-	-	-	-	-	-	-	-	-	-	-	-	-	-	-	
E295	1.0050	10025-2	-	-	-	-	-	-	-	-	-	-	-	-	-	-	-	-	-	-	-	
E315	1.0236	10297-1	-	-	-	-	-	ES300	49-646	Fe460	7946	-	-	-	-	-	-	-	-	STKM19A	G 3445	
E315	1.0236	10297-1	-	-	-	-	-	ES300	49-646	Fe460	7947	-	-	-	-	-	-	-	-	-	STKM19A	G 3445
E320	1.0237	10296-1	-	-	-	-	-	-	-	-	-	-	-	-	-	-	-	-	-	-	-	
E320	1.0237	10305-3	-	-	-	-	-	ES320	49-646	-	-	-	-	-	-	-	-	-	-	-	-	
E320	1.0237	10305-5	-	-	-	-	-	-	-	-	-	-	-	-	-	-	-	-	-	-	-	
E335	1.0060	10025-2	-	-	-	-	-	-	-	-	-	-	-	-	-	-	-	-	-	-	-	
E355	1.0580	10294-1	-	-	-	-	-	-	-	Fe52-1	663	-	-	-	-	-	-	-	-	-	-	
E355	1.0580	10296-1	-	-	-	-	-	-	-	Fe52-2	663	-	-	-	-	-	-	-	-	-	-	
E355	1.0580	10297-1	-	-	-	HFS5	6323-3	TU52-b	49-311	Fe510	7729	11523	42 0250	-	-	-	-	-	-	-	-	
E355	1.0580	10305-1	St52	1.0580	2391-2	CFS5	6323-4	TU52-b	49-310	Fe490	7945	11523	42 0260	-	-	-	1524	A519	-	-	-	
E355	1.0580	10305-2	St52-3	1.0570	2393-2	CEW5	6323-6	ES355	49-646	Fe510	7946	-	-	-	-	18G2A	84018	-	-	-	-	
E355	1.0580	10305-3	St52-3	1.0570	2394-2	ERW5	6323-5	ES355	49-646	Fe510	7947	-	-	-	-	-	-	1518	A519	-	-	
E355	1.0580	10305-4	St52.0	1.0421	1629	-	-	-	-	-	-	-	-	-	-	-	-	-	-	-	-	
E355	1.0580	10305-5	St52-3	1.0570	2395-2	-	-	-	-	-	-	-	-	-	-	-	-	-	-	-	-	
E355	1.0580	10305-6	-	-	-	-	-	-	-	-	-	-	-	-	-	-	-	-	-	-	-	
-	-	-	-	-	-	-	-	-	-	Fe510	6363	-	-	-	-	-	-	-	-	-	-	
E355K2	1.0920	10296-1	-	-	-	-	-	-	-	-	-	-	-	-	-	-	-	-	-	-	-	
E355K2	1.0920	10297-1	-	-	-	-	-	-	-	-	-	-	-	-	-	-	-	-	-	-	-	
E360	1.0070	10025-2	-	-	-	-	-	-	-	-	-	-	-	-	-	-	-	-	-	-	-	
E370	1.0261	10296-1	-	-	-	-	-	-	-	-	-	-	-	-	-	-	-	-	-	-	-	
E370	1.0261	10305-3	-	-	-	-	-	ES380	49-646	-	-	-	-	-	-	-	-	-	-	-	-	
E370	1.0261	10305-5	-	-	-	-	-	-	-	-	-	-	-	-	-	-	-	-	-	-	-	
E410	-	10305-1	-	-	-	-	-	TU20MV6	49-310	-	-	-	-	-	-	-	-	-	-	-	-	

From point of view of chemical composition are identical following steels:  
 E155 = E190, E195 = E220, E235 = E260, E275 = E320, E355 = E370 in standard EN 10305-3.



Steel	EN		DIN			BS		NFA		UNI		ČSN,STN		GOST		PN-H		ASTM		JIS	
	W.Nr.	Standard	Steel	W.Nr.	Standard	Steel	Standard	Steel	Standard	Steel	Standard	Steel	Standard	Steel	Standard	Steel	Standard	Steel	Standard	Steel	Standard
E420	1.0575	10305-3	-	-	-	-	-	ES420	49-646	-	-	-	-	-	-	-	-	-	-	-	-
E420	1.0575	10305-5	-	-	-	-	-	-	-	-	-	-	-	-	-	-	-	-	-	-	-
E420J2	1.0599	10297-1	-	-	-	-	-	-	-	-	-	-	-	-	-	-	-	-	-	-	-
E460K2	1.8891	10296-1	-	-	-	-	-	-	-	-	-	-	-	-	-	-	-	-	-	-	-
E460K2	1.8891	10297-1	-	-	-	-	-	-	-	-	-	-	-	-	-	-	-	-	-	-	-
E470	1.0536	10297-1	-	-	-	-	-	-	-	-	-	-	-	-	-	-	-	-	-	-	-
-	-	-	-	-	-	-	-	TU56-b	49-311	Fe55-1	663	11550	42 0250	-	-	R55	84023/7	1541	A519	-	-
-	-	-	-	-	-	-	-	TU56-b	49-311	Fe55-2	663	11550	42 0250	-	-	-	-	-	-	-	-
-	-	-	-	-	-	-	-	TU56-b	49-311	Fe540	7729	11550	42 0250	-	-	-	-	-	-	-	-
-	-	-	-	-	-	HFS8	6323-3	-	-	-	-	11650	42 0250	-	-	-	-	-	-	-	-
E590K2*	1.0644	10297-1	-	-	-	-	-	-	-	-	-	-	-	-	-	-	-	-	-	-	-
E730K2*	1.8893	10297-1	-	-	-	-	-	-	-	-	-	-	-	-	-	-	-	-	-	-	-
E275M*	1.8895	10296-1	-	-	-	-	-	-	-	-	-	-	-	-	-	-	-	-	-	-	-
E355M*	1.8896	10296-1	-	-	-	-	-	-	-	-	-	-	-	-	-	-	-	-	-	-	-
E460M*	1.8898	10296-1	-	-	-	-	-	-	-	-	-	-	-	-	-	-	-	-	-	-	-

\* for information only, steel grades are not produced by ŽP.

### Steels for Pipelines, Type L according to EN

Table 48

Steel	EN		DIN			BS		NFA		UNI		ČSN,STN		GOST		PN-H		API		EN - ISO	
	W.Nr.	Standard	Steel	W.Nr.	Standard	Steel	Standard	Steel	Standard	Steel	Standard	Steel	Standard	Steel	Standard	Steel	Standard	Steel	Standard	Steel	Standard
L235	1.0252	10224	-	-	-	-	-	-	-	-	-	-	-	-	-	-	-	-	-	-	-
L275	1.0260	10224	-	-	-	-	-	-	-	-	-	-	-	-	-	-	-	-	-	-	-
L355	1.0419	10224	-	-	-	-	-	-	-	-	-	-	-	-	-	-	-	-	-	-	-
-	-	-	-	-	-	-	-	-	-	-	-	-	-	-	-	-	-	A25	API5L	L175	3183
(L210GA)	1.0319	10208-1	StE210.7	1.0307	17172	-	-	TSE220	49-400	-	-	-	-	K34	20295	-	-	A	API5L	L210	3183
(L235GA)	1.0458	10208-1	St37.0	1.0254	1629	-	-	-	-	Fe35-1	7088	-	-	-	-	-	-	-	-	-	-
(L245GA)	1.0459	10208-1	-	-	-	-	-	-	-	-	-	-	-	-	-	-	-	B	API5L	L245	3183
(L290GA)	1.0483	10208-1	St44.0	1.0256	1629	-	-	-	-	Fe45-1	7088	-	-	-	-	-	-	X42	API5L	L290	3183
-	-	-	-	-	-	-	-	-	-	-	-	-	-	-	-	-	-	X46	API5L	L320	3183
(L360GA)	1.0499	10208-1	St52.0	1.0421	1629	-	-	-	-	-	-	-	-	-	-	-	-	X52	API5L	L360	3183
-	-	-	-	-	-	-	-	-	-	-	-	-	-	-	-	-	-	X56	API5L	L390	3183
(L245NB)	1.0457	10208-2	StE240.7	1.0457	17172	-	-	TSE250	49-400	-	-	-	-	K38	20295	-	-	BN	API5L	L245N	3183
(L290NB)	1.0484	10208-2	StE290.7	1.0484	17172	-	-	-	-	-	-	-	-	K42	20295	-	-	X42N	API5L	L290N	3183
-	-	-	StE290.7	1.0484	2609	-	-	-	-	-	-	-	-	-	-	-	-	-	-	-	-
-	-	-	StE320.7	1.0409	17172	-	-	TSE320	49-400	-	-	-	-	K50	20295	-	-	X46N	API5L	L320N	-
(L360NB)	1.0582	10208-2	StE360.7	1.0582	17172	-	-	TSE360	49-400	-	-	-	-	K52	20295	-	-	X52N	API5L	L360N	3183
-	-	-	StE360.7	1.0582	2609	-	-	-	-	-	-	-	-	-	-	-	-	-	-	-	-
-	-	-	StE385.7	1.8970	17172	-	-	-	-	-	-	-	-	-	-	-	-	-	-	-	-
-	-	-	-	-	-	-	-	-	-	-	-	-	-	K55	20295	-	-	X56N	API5L	L390N	-
(L415NB)	1.8972	10208-2	StE415.7	1.8972	17172	-	-	TSE415	49-400	-	-	-	-	K60	20295	-	-	X60N	API5L	L415N	3183
(L415NB)	1.8972	10253-2	-	-	-	-	-	-	-	-	-	-	-	-	-	-	-	-	-	-	-
-	-	-	StE445.7TM	1.8975	17172	-	-	-	-	-	-	-	-	-	-	-	-	-	-	-	-
(L450.B)	-	10208-2	-	-	-	-	-	-	-	-	-	-	-	-	-	-	-	X65	API5L	L450x	3183
-	-	-	StE480.7TM	1.8977	17172	-	-	-	-	-	-	-	-	-	-	-	-	-	-	-	-
(L485.B)	-	10208-2	-	-	-	-	-	-	-	-	-	-	-	-	-	-	-	X70	API5L	L485x	3183
(L555.B)	-	10208-2	-	-	-	-	-	-	-	-	-	-	-	-	-	-	-	X80	API5L	L555x	3183
-	-	-	-	-	-	-	-	-	-	-	-	-	-	-	-	-	-	H40	API5CT	-	-
-	-	-	-	-	-	-	-	-	-	-	-	-	-	-	-	-	-	J55	API5CT	-	-
-	-	-	-	-	-	-	-	-	-	-	-	-	-	-	-	-	-	K55	API5CT	-	-
-	-	-	-	-	-	-	-	-	-	-	-	-	-	-	-	-	-	N80	API5CT	-	-

Standards EN 10208-1; -2 are withdrawn

Steels for tubes for pressure purposes, Type P according to EN

Table 49

Steel	EN		DIN			BS		NFA		UNI	ČSN,STN		GOST		PN-H		ASTM		JIS	
	W.Nr.	Standard	Steel	W.Nr.	Standard	Steel	Standard	Steel	Standard	Steel	Steel	Steel	Standard	Steel	Standard	Steel	Standard	Steel	Standard	
P195TR1	1.0107	10216-1	-	-	-	-	-	-	-	Fe320	-	-	-	-	-	-	-	-	-	-
P195TR1	1.0107	10217-1	-	-	-	-	-	-	-	Fe320	-	-	-	-	-	-	-	-	-	-
P195TR2	1.0108	10216-1	-	-	-	-	-	-	-	-	-	-	-	-	-	A822	A822	-	-	
P195TR2	1.0108	10217-1	-	-	-	-	-	-	-	-	-	-	-	-	-	A822	A822	-	-	
P195GH	1.0348	10216-2	-	-	-	320	3059-1	-	-	-	-	-	-	-	-	-	-	-	-	
P195GH	1.0348	10217-2	-	-	-	320	3606	TS34-C	49-245	-	-	-	-	-	-	-	-	-	-	
P215NL	1.0451	10216-4	TTS35N	1.0356	17173	430LT	3603	-	-	C15	11369	-	-	-	-	Gr.1	A333	STPL380	G3460	
P215NL	1.0451	10217-4	TTS35N	1.0356	17174	-	-	-	-	-	-	-	-	-	-	Gr.1	A334	STBL380	G3464	
P215NL	1.0451	10217-6	-	-	-	-	-	-	-	-	-	-	-	-	-	-	-	-	-	
P215NL	1.0451	10253-2	-	-	-	-	-	-	-	-	-	-	-	-	-	-	-	-	-	
P235	-	10253-2	-	-	-	-	-	-	-	-	-	-	-	-	-	-	-	-	-	
P235TR1	1.0254	10216-1	St37.0	1.0254	1629	-	-	-	-	Fe320	11353	-	-	-	-	-	-	-	-	
P235TR1	1.0254	10216-1	St37.0	1.0254	2609	-	-	-	-	-	-	-	-	-	-	-	-	-	-	
P235TR1	1.0254	10217-1	St37.0	1.0254	1626	-	-	-	-	-	-	-	-	-	-	-	-	-	-	
P235TR2	1.0255	10216-1	St37.4	1.0255	1630	360	3601	-	-	-	-	-	-	R35	84023	-	-	STPG370	G3454	
P235TR2	1.0255	10217-1	St37.4	1.0255	1628	-	-	-	-	-	-	-	-	-	-	-	-	STS370	G3455	
P235TR2	1.0255	10216-1	-	-	-	CFS360	7416	TUE220A	49-112	-	-	-	-	-	-	-	-	-	-	
P235TR2	1.0255	10216-1	-	-	-	-	-	AE220A	49-186	-	-	-	-	-	-	-	-	-	-	
P235TR2	1.0255	10216-1	-	-	-	-	-	AE220	49-281	-	-	-	-	-	-	-	-	-	-	
P235TR2	1.0255	10253-2	-	-	-	-	-	-	-	-	-	-	-	-	-	-	-	-	-	
P235GH	1.0345	10216-2	St35.8	1.0305	17175	360	3059-2	TU37c	49-213	C14	12021	10	1050	K10	74252	Gr.A	A106	STPT370	G3456	
P235GH	1.0345	10216-2	St35.8	1.0305	17175	360	3602-1	TU37c	49-215	C14	12021	10	1050	K10	74252	A179	A179	STPT370	G3456	
P235GH	1.0345	10216-2	St35.8	1.0305	17175	360	3602-1	TU37c	49-215	C14	12021	10	1050	K10	74252	A192	A192	STPT370	G3456	
P235GH	1.0345	10216-2	St35.8	1.0305	17175	360	3602-1	TU37c	49-215	C14	12021	10	1050	K10	74252	Gr.A-2	A556	STPT370	G3456	
P235GH	1.0345	10216-2	St35.8	1.0305	2609	-	-	TUE220	49-211	-	-	-	-	-	-	Gr.A	A178	STB340	G3461	
P235GH	1.0345	10216-2	St35.8	1.0305	2609	-	-	TUE220	49-211	-	-	-	-	-	-	A214	A214	STB340	G3461	
P235GH	1.0345	10217-2	St37.8	1.0315	17177	-	-	TS37C	49-243	-	-	-	-	-	-	-	-	-	-	
P235GH	1.0345	10217-5	St37.8	1.0315	17177	-	-	TS37C	49-245	-	-	-	-	-	-	-	-	-	-	
-	-	-	StE255	1.0461	17179	-	-	-	-	-	-	-	-	-	-	-	-	-	-	
-	-	-	StE255	1.0461	17178	-	-	-	-	-	-	-	-	-	-	-	-	-	-	
-	-	-	WStE255	1.0462	17179	-	-	-	-	-	-	-	-	-	-	-	-	-	-	
-	-	-	WStE255	1.0462	17178	-	-	-	-	-	-	-	-	-	-	-	-	-	-	
-	-	-	TStE255	1.0463	17179	-	-	-	-	-	-	-	-	-	-	-	-	-	-	
-	-	-	TStE255	1.0463	17178	-	-	-	-	-	-	-	-	-	-	-	-	-	-	
-	-	-	EStE255	1.1103	17179	-	-	-	-	-	-	-	-	-	-	-	-	-	-	
-	-	-	EStE255	1.1103	17178	-	-	-	-	-	-	-	-	-	-	-	-	-	-	
P255QL	1.0452	10216-4	-	-	-	-	-	-	-	-	-	-	-	-	-	-	-	-	-	
P265	-	10253-2	-	-	-	-	-	-	-	-	-	-	-	-	-	-	-	-	-	
P265TR1	1.0258	10216-1	St44.0	1.0256	1629	-	-	-	-	-	11453	-	-	-	-	-	-	-	-	
P265TR1	1.0258	10216-1	St44.0	1.0256	2609	-	-	-	-	-	11453	-	-	-	-	-	-	-	-	
P265TR1	1.0258	10217-1	St44.0	1.0256	1626	-	-	-	-	-	-	-	-	-	-	-	-	-	-	
-	-	-	-	-	-	430	3601	-	-	-	-	-	-	-	-	-	-	-	-	
P265TR2	1.0259	10216-1	St44.4	1.0257	1630	CFS430	7416	TUE235A	49-112	-	-	-	-	R45	84023	-	-	STPG410	G3454	
P265TR2	1.0259	10217-1	St44.4	1.0257	1628	-	-	-	-	-	-	-	-	R45	84023	-	-	STS410	G3455	
P265TR2	1.0259	10253-2	St44.4	1.0257	2609	-	-	-	-	-	-	-	-	-	-	-	-	-	-	
P265GH	1.0425	10216-2	St45.8	1.0405	17175	430	3602-1	TU42c	49-213	C18	12022	20	1050	K18	74252	Gr.B	A106	STPT410	G3456	
P265GH	1.0425	10216-2	St45.8	1.0405	17175	430	3059-2	TU42c	49-215	C18	12022	20	1050	K18	74252	Gr.A-1	A210	STPT410	G3456	
P265GH	1.0425	10216-2	St45.8	1.0405	17175	430	3602-1	TUE250	49-211	-	-	-	-	-	-	Gr.B-2	A556	-	-	
P265GH	1.0425	10216-2	St45.8	1.0405	17175	430	3602-1	TUE250	49-281	-	-	-	-	-	-	WPB	A234	-	-	
P265GH	1.0425	10217-2	St42.8	1.0498	17177	440	3606	TS42c	49-243	-	-	-	-	-	-	Gr.B	A178	STB410	G3461	
P265GH	1.0425	10217-5	St42.8	1.0498	17177	440	3606	TS42c	49-245	-	-	-	-	-	-	Gr.B	A178	STB410	G3461	
P265NL	1.0453	10216-4	TTS35V	1.0356	17173	430LT	3603	TU42BT	49-215	C20	11419	-	-	-	-	Gr.6	A333	-	-	
P265NL	1.0453	10217-4	TTS35V	1.0356	17174	430LT	3603	TU42BT	49-215	C20	11448	-	-	-	-	Gr.6	A334	-	-	
P265NL	1.0453	10217-6	TTS35V	1.0356	17173	430LT	3603	TU42BT	49-215	C20	11419	-	-	-	-	WPL6	A420	-	-	
P265NL	1.0453	10253-2	-	-	-	-	-	TU48c	49-213	-	-	-	-	-	-	-	-	STS480	G3455	
-	-	-	-	-	-	-	-	TU48c	49-215	-	-	-	-	-	-	-	-	-	-	
-	-	-	-	-	-	-	-	TS48c	49-243	-	-	-	-	-	-	-	-	-	-	
-	-	-	-	-	-	-	-	TS48c	49-245	-	-	-	-	-	-	-	-	-	-	
-	-	-	-	-	-	-	-	AE275	49-281	-	-	-	-	-	-	-	-	-	-	
-	-	-	StE285	1.0486	17179	-	-	TUE290B2	49-411	-	-	-	-	-	-	-	-	-	-	
-	-	-	StE285	1.0486	17178	-	-	-	-	-	-	-	-	-	-	-	-	-	-	
-	-	-	WStE285	1.0487	17179	-	-	-	-	-	-	-	-	-	-	-	-	-	-	
-	-	-	WStE285	1.0487	17178	-	-	-	-	-	-	-	-	-	-	-	-	-	-	
P275NL1	1.0488	10216-3	TStE285	1.0488	17179	-	-	TUE290B3	49-411	-	-	-	-	-	-	-	-	-	-	
P275NL1	1.0488	10216-3	TStE285	1.0488	2609	-	-	-	-	-	-	-	-	-	-	-	-	-	-	
P275NL1	1.0488	10217-3	TStE285	1.0488	17178	-	-	-	-	-	-	-	-	-	-	-	-	-	-	
P275NL2	1.1104	10216-3	EStE285	1.1104	17179	-	-	-	-	-	-	-	-	-	-	-	-	-	-	
P275NL2	1.1104	10217-3	EStE285	1.1104	17178	-	-	-	-	-	-	-	-	-	-	-	-	-	-	
-	-	-	St52.0	1.0421	1629	-	-	-	-	-	11523	-	-	-	-	-	-	-	-	
-	-	-	St52.0	1.0421	2609	-	-	-	-	-	-	-	-	-	-	-	-	-	-	
-	-	-	St52.0	1.0421	1626	-	-	-	-	-	-	-	-	-	-	-	-	-	-	
-	-	-	St52.4	1.0581	1630	-	-	-	-	-	-	-	-	-	-	-	-	-	-	
-	-	-	St52.4	1.0581	1628	-	-	-	-	-	-	-	-	-	-	-	-	-	-	
P355N	1.0562	10216-3	StE355	1.0562	17179	-	-	TUE360B2	49-411	-	-	-	-	-	-	-	-	-	-	
P355N	1.0562	10253-2	StE355	1.0562	17179	-	-	-	-	-	-	-	-	-	-	-	-	-	-	
P355N	1.0562	10217-3	StE355	1.0562	17178	-	-	-	-	-	-	-	-	-	-	-	-	-	-	





Steel	EN		Steel	DIN		Steel	BS		Steel	NFA		Steel	UNI ČSN, STN		Steel	GOST		Steel	PN-H		Steel	ASTM		Steel	JIS	
	W.Nr.	Standard		W.Nr.	Standard		Steel	Standard		Steel	Standard		Steel	Standard		Steel	Standard		Steel	Standard		Steel	Standard		Steel	Standard
P355NH	1.0565	10216-3	WStE355	1.0565	17179	-	-	-	-	-	-	-	-	-	-	-	-	-	-	-	-	-	-	-	-	
P355NH	1.0565	10253-2	WStE355	1.0565	2609	-	-	-	-	-	-	-	-	-	-	-	-	-	-	-	-	-	-	-	-	
P355NH	1.0565	10217-3	WStE355	1.0565	17178	-	-	-	-	-	-	-	-	-	-	-	-	-	-	-	-	-	-	-	-	
P355NL1	1.0566	10216-3	TStE355	1.0566	17179	-	-	TUE360B3	49-411	-	11503	-	-	-	-	-	-	-	-	-	-	-	-	-	-	
P355NL1	1.0566	10217-3	TStE355	1.0566	17178	-	-	-	-	-	11503	-	-	-	-	-	-	-	-	-	-	-	-	-	-	
P355NL1	1.0566	10253-2	TStE355	1.0566	2609	-	-	-	-	-	11503	-	-	-	-	-	-	-	-	-	-	-	-	-	-	
P355NL2	1.1106	10216-3	EStE355	1.1106	17179	-	-	-	-	-	-	-	-	-	-	-	-	-	-	-	-	-	-	-	-	
P355NL2	1.1106	10217-3	EStE355	1.1106	17178	-	-	-	-	-	-	-	-	-	-	-	-	-	-	-	-	-	-	-	-	
			StE420	1.8902	17179	-	-	TUE420B2	49-411	-	-	-	-	-	-	-	-	-	-	-	-	-	-	-	-	
			StE420	1.8902	17178	-	-	-	-	-	-	-	-	-	-	-	-	-	-	-	-	-	-	-	-	
			WStE420	1.8932	17179	-	-	-	-	-	-	-	-	-	-	-	-	-	-	-	-	-	-	-	-	
			WStE420	1.8932	17178	-	-	-	-	-	-	-	-	-	-	-	-	-	-	-	-	-	-	-	-	
			TStE420	1.8912	17179	-	-	TUE420B3	49-411	-	-	-	-	-	-	-	-	-	-	-	-	-	-	-	-	
			TStE420	1.8912	17178	-	-	-	-	-	-	-	-	-	-	-	-	-	-	-	-	-	-	-	-	
			EStE420	1.8913	17179	-	-	-	-	-	-	-	-	-	-	-	-	-	-	-	-	-	-	-	-	
			EStE420	1.8913	17178	-	-	-	-	-	-	-	-	-	-	-	-	-	-	-	-	-	-	-	-	
P460N	1.8905	10216-3	StE460	1.8905	17179	-	-	TUE485B2	49-411	-	-	-	-	-	-	-	-	-	-	-	-	-	-	-	-	
P460N	1.8905	10217-3	StE460	1.8905	17178	-	-	-	-	-	-	-	-	-	-	-	-	-	-	-	-	-	-	-	-	
P460NH	1.8935	10216-3	WStE460	1.8935	17179	-	-	-	-	-	-	-	-	-	-	-	-	-	-	-	-	-	-	-	-	
P460NH	1.8935	10217-3	WStE460	1.8935	17178	-	-	-	-	-	-	-	-	-	-	-	-	-	-	-	-	-	-	-	-	
P460NL1	1.8915	10216-3	TStE460	1.8915	17179	-	-	TUE485B3	49-411	-	-	-	-	-	-	-	-	-	-	-	-	-	-	-	-	
P460NL1	1.8915	10217-3	TStE460	1.8915	17178	-	-	-	-	-	-	-	-	-	-	-	-	-	-	-	-	-	-	-	-	
P460NL2	1.8918	10216-3	EStE460	1.8918	17179	-	-	-	-	-	-	-	-	-	-	-	-	-	-	-	-	-	-	-	-	
P460NL2	1.8918	10217-3	EStE460	1.8918	17178	-	-	-	-	-	-	-	-	-	-	-	-	-	-	-	-	-	-	-	-	
*P620Q	1.8876	10216-3	-	-	-	-	-	-	-	-	-	-	-	-	-	-	-	-	-	-	-	-	-	-	-	
*P620QH	1.8877	10216-3	-	-	-	-	-	-	-	-	-	-	-	-	-	-	-	-	-	-	-	-	-	-	-	
*P620QL	1.8890	10216-3	-	-	-	-	-	-	-	-	-	-	-	-	-	-	-	-	-	-	-	-	-	-	-	
*P690Q	1.8879	10216-3	-	-	-	-	-	-	-	-	-	-	-	-	-	-	-	-	-	-	-	-	-	-	-	
*P690QH	1.8880	10216-3	-	-	-	-	-	-	-	-	-	-	-	-	-	-	-	-	-	-	-	-	-	-	-	
*P690QL1	1.8881	10216-3	-	-	-	-	-	-	-	-	-	-	-	-	-	-	-	-	-	-	-	-	-	-	-	
*P690QL2	1.8888	10216-3	-	-	-	-	-	-	-	-	-	-	-	-	-	-	-	-	-	-	-	-	-	-	-	

\* for information only, steel grades are not produced by ŽP.

Steels for tubes for steel structures, Type S according to EN

Table 50

Steel	EN		DIN			BS		NFA		UNI	ČSN,STN	GOST		PN-H		ASTM		JIS	
	W.Nr.	Standard	Steel	W.Nr.	Standard	Steel	Standard	Steel	Standard	Steel	Steel	Steel	Standard	Steel	Standard	Steel	Standard	Steel	Standard
S185	1.0035	10025-2	S33-2	1.0035	17100	-	-	-	-	-	-	-	-	-	-	-	-	-	-
S195T	1.0026	10255	-	-	-	BS1387	1387	TU34-1	49-115	Fe330	-	-	-	-	-	GrA	A53	STK290	G3444
S235	-	10253-1	S37.0	1.0254	2609	-	-	-	-	-	11353	-	-	-	-	-	-	-	-
S235JRH	1.0039	10210-1	RSt37-2	1.0038	17119	-	-	-	-	-	11373	-	-	-	-	-	-	-	-
S235JRH	1.0039	10219-1	RSt37-2	1.0038	17120	-	-	-	-	-	11373	-	-	-	-	A795	A795	-	-
S235JR	1.0038	10025-2	RSt37-2	1.0038	17121	HFS 3	6323-3	TUE235/Q2	49-501	Fe35-1	11353	10	1050	R 35	84023/7	Gr.A	A53	-	-
-	-	-	S37-3	1.0116	17119	-	-	-	-	-	11373	-	-	-	-	-	-	-	-
S235JRG2	-	-	S37-3	1.0116	17120	-	-	-	-	-	11375	-	-	-	-	-	-	-	-
-	-	-	S37-3	1.0116	17121	-	-	-	-	-	-	11353	-	-	-	-	-	-	-
S265	-	10253-1	S44.0	1.0256	2609	-	-	-	-	-	-	-	-	-	-	-	-	-	-
S275JOH	1.0149	10210-1	S44-2	1.0044	17119	-	-	-	-	-	11443	-	-	-	-	-	-	-	-
S275JOH	1.0149	10219-1	S44-2	1.0044	17120	-	-	-	-	-	11425	-	-	-	-	-	-	-	-
S275JO	1.0143	10025-2	S44-2	1.0044	17121	-	-	-	-	-	11453	-	-	-	-	-	-	STK 400	G 3444
S275J2H	1.0138	10210-1	S44-3	1.0144	17119	-	-	-	-	-	11448	-	-	-	-	-	-	-	-
S275J2H	1.0138	10219-1	S44-3	1.0144	17120	SAW 4	6323-7	TUE275/Q4	49-501	-	11448	-	-	-	-	-	-	-	-
S275J2	1.0145	10025-2	S44-3	1.0144	17121	HFS 4	6323-3	TUE275/Q3	49-501	Fe45-1	11453	20	1050	R 45	84023/7	Gr.B	A53	-	-
-	-	-	StE255	1.0461	17123	-	-	-	-	-	-	-	-	-	-	-	-	-	-
-	-	-	StE255	1.0461	17124	-	-	-	-	-	-	-	-	-	-	-	-	-	-
-	-	-	StE255	1.0461	17125	-	-	-	-	-	-	-	-	-	-	-	-	-	-
-	-	-	TStE255	1.0463	17123	-	-	-	-	-	-	-	-	-	-	-	-	-	-
-	-	-	TStE255	1.0463	17124	-	-	-	-	-	-	-	-	-	-	-	-	-	-
-	-	-	TStE255	1.0463	17125	-	-	-	-	-	-	-	-	-	-	-	-	-	-
-	-	-	EstE255	1.1103	17123	-	-	-	-	-	-	-	-	-	-	-	-	-	-
-	-	-	EstE255	1.1103	17124	-	-	-	-	-	-	-	-	-	-	-	-	-	-
-	-	-	EstE255	1.1103	17125	-	-	-	-	-	-	-	-	-	-	-	-	-	-
S275NH	1.0493	10210-1	StE285	1.0486	17123	-	-	-	-	-	-	-	-	-	-	-	-	-	-
S275NH	1.0493	10219-1	StE285	1.0486	17124	-	-	-	-	-	-	-	-	-	-	-	-	-	-
S275N	1.0490	10025-3	StE285	1.0486	17125	-	-	-	-	-	-	-	-	-	-	-	-	-	-
S275NLH	1.0497	10210-1	TStE285	1.0488	17123	-	-	-	-	-	-	-	-	-	-	-	-	-	-
S275NLH	1.0497	10219-1	TStE285	1.0488	17124	-	-	-	-	-	-	-	-	-	-	-	-	-	-
S275NL	1.0491	10025-3	TStE285	1.0488	17125	-	-	-	-	-	-	-	-	-	-	-	-	-	-
-	-	-	EstE285	1.1104	17123	-	-	-	-	-	-	-	-	-	-	-	-	-	-
-	-	-	EstE285	1.1104	17124	-	-	-	-	-	-	09G2S	19281	09G2	84018	-	-	STK 490	G 3444
-	-	-	EstE285	1.1104	17125	-	-	-	-	-	-	-	-	-	-	-	-	-	-
S275MH	1.8843	10219-1	-	-	-	-	-	-	-	-	-	-	-	-	-	-	-	-	-
S275MLH	1.8844	10219-1	-	-	-	-	-	-	-	-	-	-	-	-	-	-	-	-	-
S355JOH	1.0547	10210-1	StE52-3	1.0570	17119	-	-	-	-	-	-	-	-	-	-	-	-	-	-
S355JOH	1.0547	10219-1	StE52-3	1.0570	17120	SAW 5	6323-7	-	-	-	-	-	-	-	-	-	-	-	-
S355JO	1.0553	10025-2	StE52-3	1.0570	17121	HFS 5	6323-3	TUE355/Q3	49-501	Fe 52-1	11523	18G2	19281	18G2A	84018	-	-	STK 500	G 3444
S355J2H	1.0576	10210-1	StE52-3	1.0570	17119	-	-	-	-	-	-	-	-	-	-	-	-	-	-
S355J2H	1.0576	10219-1	StE52-3	1.0570	17120	-	-	-	-	-	-	-	-	-	-	-	-	-	-
S355J2G3	-	-	StE52-3	1.0570	17121	-	-	-	-	-	11523	-	-	-	-	-	-	-	-
S355NH	1.0539	10210-1	StE355	1.0562	17123	-	-	-	-	-	-	-	-	-	-	-	-	-	-
S355NH	1.0539	10219-1	StE355	1.0562	17124	-	-	-	-	-	-	-	-	-	-	-	-	-	-
S355N	1.0545	10025-3	StE355	1.0562	17125	-	-	-	-	-	-	-	-	-	-	-	-	-	-
S355NLH	1.0549	10210-1	TStE355	1.0566	17123	-	-	-	-	-	-	-	-	-	-	-	-	-	-
S355NLH	1.0549	10219-1	TStE355	1.0566	17124	-	-	-	-	-	11503	-	-	-	-	-	-	-	-
S355NL	1.0546	10025-3	TStE355	1.0566	17125	-	-	-	-	-	-	-	-	-	-	-	-	-	-
-	-	-	EstE355	1.1106	17123	-	-	-	-	-	-	-	-	-	-	-	-	-	-
-	-	-	EstE355	1.1106	17124	-	-	-	-	-	-	-	-	-	-	-	-	-	-
-	-	-	EstE355	1.1106	17125	-	-	-	-	-	-	-	-	-	-	-	-	-	-
S355MH	1.8845	10219-1	-	-	-	-	-	-	-	-	-	-	-	-	-	-	-	-	-
S355MLH	1.8846	10219-1	-	-	-	-	-	-	-	-	-	-	-	-	-	-	-	-	-
-	-	-	StE420	1.8902	17123	-	-	-	-	-	-	-	-	-	-	-	-	STK 540	G 3444
-	-	-	StE420	1.8902	17124	-	-	-	-	-	-	-	-	-	-	-	-	-	-
-	-	-	StE420	1.8902	17125	-	-	-	-	-	-	-	-	-	-	-	-	-	-
-	-	-	TStE420	1.8912	17123	-	-	-	-	-	-	-	-	-	-	-	-	-	-
-	-	-	TStE420	1.8912	17124	-	-	-	-	-	-	-	-	-	-	-	-	-	-
-	-	-	TStE420	1.8912	17125	-	-	-	-	-	-	-	-	-	-	-	-	-	-
-	-	-	EstE420	1.8913	17123	-	-	-	-	-	-	-	-	-	-	-	-	-	-
-	-	-	EstE420	1.8913	17124	-	-	-	-	-	-	-	-	-	-	-	-	-	-
-	-	-	EstE420	1.8913	17125	-	-	-	-	-	-	-	-	-	-	-	-	-	-
S420MH	1.8847	-	-	-	-	-	-	-	-	-	-	-	-	-	-	-	-	-	-
S420MLH	1.8848	-	-	-	-	-	-	-	-	-	-	-	-	-	-	-	-	-	-
S460NH	1.8953	10210-1	StE460	1.8905	17123	-	-	TUE450/Q4	49-501	-	-	-	-	-	-	-	-	-	-
S460NH	1.8953	10219-1	StE460	1.8905	17124	-	-	-	-	-	-	-	-	-	-	-	-	-	-
S460N	1.8901	10025-3	StE460	1.8905	17125	-	-	-	-	-	-	-	-	-	-	-	-	-	-
S460NLH	1.8956	10210-1	TStE460	1.8915	17123	-	-	-	-	-	-	-	-	-	-	-	-	-	-
S460NLH	1.8956	10219-1	TStE460	1.8915	17124	-	-	-	-	-	-	-	-	-	-	-	-	-	-
S460NL	1.8903	10025-3	TStE460	1.8915	17125	-	-	-	-	-	-	-	-	-	-	-	-	-	-
-	-	-	EstE460	1.8918	17123	-	-	-	-	-	-	-	-	-	-	-	-	-	-
-	-	-	EstE460	1.8918	17124	-	-	-	-	-	-	-	-	-	-	-	-	-	-
-	-	-	EstE460	1.8918	17125	-	-	-	-	-	-	-	-	-	-	-	-	-	-
S460MH	1.8849	10219-1	-	-	-	-	-	-	-	-	-	-	-	-	-	-	-	-	-
S460MLH	1.8850	10219-1	-	-	-	-	-	-	-	-	-	-	-	-	-	-	-	-	-

Steels for pressure purposes - alloyed, Type 16Mo3 according to EN

Table 51

EN			DIN			BS		NFA		UNI	ČSN, STN	GOST		PN-H		ASTM		JIS	
Steel	W.Nr.	Standard	Steel	W.Nr.	Standard	Steel	Standard	Steel	Standard	Steel	Steel	Steel	Standard	Steel	Standard	Steel	Standard	Steel	Standard
<b>Mn steel</b>																			
(P295 GH)	1.0481	-	17Mn4	1.0481	17175	440	3059-2	TUE275	49-211	-	11481	14G2	4543	-	-	Gr.C	A106	STPT480	G3456
-	-	-	17Mn4	1.0481	17175	-	-	TUE275	49-211	-	13030	-	-	-	-	Gr.C	A178	-	-
-	-	-	17Mn4	1.0481	17175	-	-	TUE275	49-211	-	-	-	-	-	-	Gr.C	A210	-	-
-	-	-	17Mn4	1.0481	17175	-	-	TUE275	49-211	-	-	-	-	-	-	WPC	A234	-	-
(P310 GH)	1.0482	-	19Mn5	1.0482	17175	-	-	TU52c	49-213	-	-	-	-	-	-	Gr.C2	A556	-	-
(P355 GH)	1.0473	-	19Mn6	1.0473	17155	-	-	TS52C	49-243	-	-	-	-	-	-	Gr.D	A178	STB510	G3461
<b>Mn + Nb,V steel</b>																			
20MnNb6	1.0471	10216-2	-	-	-	-	-	-	-	-	-	-	-	-	-	-	-	-	-
17MnV4	-	-	17MnV4	-	-	-	-	-	-	-	12025	-	-	-	-	-	-	-	-
<b>Mo steel</b>																			
16Mo3	1.5415	10216-2	15Mo3	1.5415	17175	243	3059-2	TU15D3	49-213	16Mo3	15020	-	-	16M	74252	-	-	-	-
16Mo3	1.5415	10217-2	15Mo3	1.5415	17177	243	3606	TU15D3	49-215	-	15020	-	-	16M	74252	-	-	-	-
16Mo3	1.5415	10217-5	15Mo3	1.5415	17177	-	-	-	-	-	-	-	-	-	-	-	-	-	-
16Mo3	1.5415	10253-2	15Mo3	1.5415	2609	-	-	-	-	-	-	-	-	-	-	-	-	-	-
-	-	-	-	-	-	-	-	TS15D3	49-243	-	-	-	-	-	-	-	-	-	-
-	-	-	16Mo5	1.5423	-	-	-	-	-	16Mo5	-	-	-	-	-	T1, T1a, T1b	A209	STBA12	G3462
-	-	-	-	-	-	-	-	-	-	16Mo5	-	-	-	-	-	P 1	A335	STPA12	G3458
20Mo5	1.5419	10213-2	-	-	-	245	3606	-	-	-	-	-	-	-	-	A 692	A692	STBA13	G3462
8Mo B 5 - 4	1.5450	10216-2	-	-	-	261	3606	-	-	-	-	-	-	-	-	-	-	-	-
<b>Cr - Mo steel</b>																			
25CrMo4	1.7218	10216-2	-	-	-	-	-	-	-	-	-	-	-	-	-	-	-	-	-
26CrMo4-2	1.7219	10216-4	26CrMo4	1.7219	17173	-	-	-	-	-	-	-	-	-	-	-	-	-	-
(15CrMo2-5)	-	-	-	-	-	-	-	TU15CD2-05	49-213	-	-	-	-	-	-	T 2	A213	STBA20	G3462
-	-	-	-	-	-	-	-	TU15CD2-05	49-213	-	-	-	-	-	-	P 2	A335	STPA20	G3458
13CrMo4-5	1.7335	10216-2	13CrMo4 4	1.7335	17175	620	3059-2	TU13CD4-04	49-213	14CrMo3	15 121	15ChM	4543	15HM	74252	T 12	A213	STBA22	G3462
13CrMo4-5	1.7335	10253 - 2	13CrMo4 4	1.7335	2609	620- 440	3604-1	TU13CD4-04	49-215	-	-	-	-	-	-	P 12	A335	STPA22	G3458
-	-	-	-	-	-	620	3606	-	-	-	-	-	-	-	-	-	-	-	-
10CrMo5-5	1.7338	10216 - 2	-	-	-	621	3604-1	TU10CD05-05	49-213	-	-	-	-	-	-	T 11	A213	STBA23	G3462
10CrMo5-5	1.7338	10253 - 2	-	-	-	621	3604-2	-	-	-	-	-	-	-	-	P 11	A335	STPA23	G3458
-	-	-	-	-	-	621	3606	-	-	-	-	-	-	-	-	-	-	-	-
10CrMo9-10	1.7380	10216 - 2	10CrMo9 10	1.7380	17175	622-490	3059-2	TU10CD09-10	49-213	12CrMo9 10	15313	10Ch2M	5520	-	-	T 22	A213	STBA24	G3462
10CrMo9-10	1.7380	10253 - 2	10CrMo9 10	1.7380	2609	622	3604-1	-	-	-	-	-	-	-	-	P 22	A335	STPA24	G3458
11CrMo9-10	1.7383	10216 - 2	-	-	-	622	3606	-	-	-	-	-	-	-	-	-	-	-	-
-	-	-	12CrMo12-10	1.7381	17176	-	-	-	-	-	-	-	-	-	-	T 21	A213	-	-
-	-	-	12CrMo12-10	1.7381	-	-	-	-	-	-	-	-	-	-	-	P 21	A335	-	-
X11CrMo5	1.7362	10216 - 2	12CrMo19 5	1.7362	17176	625	3604-1	TUZ10CD5-05	49-213	-	17102	15Ch5M	550	-	-	T5,T5b,T5c	A213	STBA25	G3462
X11CrMo5	1.7362	10253 - 2	12CrMo19 5	1.7362	17176	625	3606	TUZ12CD5-05	49-215	-	17102	15Ch5M	20072	-	-	P5,P5b,P5c	A335	STPA25	G3458
(X12CrMo7)	(1.7368)	-	-	-	-	-	-	-	-	-	-	-	-	-	-	(T7)	A213	-	-
(X12CrMo7)	(1.7368)	-	-	-	-	-	-	-	-	-	-	-	-	-	-	(P7)	A335	-	-
X11CrMo9-1	1.7386	10216 - 2	X12CrMo9 1	1.7386	17176	629	3059-2	TUZ10CD9	49-213	-	17116	-	-	-	-	T 9	A213	STBA26	G3462
X11CrMo9-1	1.7386	10253 - 2	-	-	-	629	3604-1	-	-	-	-	-	-	-	-	P 9	A335	STPA26	G3458
<b>Cr-Mo-V steel, alloyed also with B, Cu, Nb, Ni, Ti, W</b>																			
7CrMoVTiB10-10	1.7378	-	17CrMoV 10	1.7766	590	-	-	-	-	-	15323	-	-	-	-	T 24	A213	-	-
7CrMoVTiB10-10	1.7378	-	-	-	-	-	-	-	-	-	-	-	-	-	-	P 24	A335	-	-
(12CrV2-2)	(1.75XY)	-	8CrMoNiNb9 10	1.6770	640	-	-	-	-	-	-	15418	-	-	-	-	-	-	-
14MoV 6 - 3	1.7715	10216-2	14MoV6 3	1.7715	17175	660	3604-1	14DCV 6	49-213	-	15110	-	-	-	-	-	-	-	-
(16CrMoV3-5-5)	(1.77XY)	-	-	-	-	-	-	-	-	-	15229	-	-	-	-	-	-	-	-
(12CrMoV4-3-2)	(1.77XY)	-	-	-	-	-	-	-	-	-	-	12Ch1MF	20072	-	-	-	-	-	-
20CrMoV13-5-5	1.7779	10216-2	20CrMoV13 5	1.7779	17176	-	-	-	-	-	15423	-	-	-	-	-	-	-	-
X10CrMoVNb9-1	1.4903	10216-2	-	-	-	629-590	3059-2	TUZ10CDVNb09-01	49-213	-	17119	-	-	-	-	T 91	A213	STBA28	G3462
X10CrMoVNb9-1	1.4903	10253-2	-	-	-	-	-	TUZ10CDVNb09-01	49-213	-	17119	-	-	-	-	P 91	A335	STPA28	G3458
X20CrMoV11-1	1.4922	10216-2	X20CrMoV12 1	1.4922	17175	762	3059-2	-	-	-	17134	-	-	-	-	-	-	-	-
X20CrMoV11-1	1.4922	10216-2	X20CrMoV12 1	1.4922	17175	762	3604-1	-	-	-	17134	-	-	-	-	-	-	-	-
7CrWVMoNb9-6	-	-	-	-	-	-	-	-	-	-	-	-	-	-	-	T 23	A213	HCM 25	-
X11CrMoWVNb9-1-1	-	-	-	-	-	-	-	-	-	-	-	-	-	-	-	T / P 911	A 213	-	-
X10CrWVMoNb 9-2	-	-	-	-	-	-	-	-	-	-	-	-	-	-	-	T / P 92	A 213	STBA 29	-
11CrWCuMoVNbNB	-	-	-	-	-	-	-	-	-	-	-	-	-	-	-	T / P 122	A 213	HCM 12A	-
<b>Ni steel</b>																			
(10Ni9)	(1.56XY)	-	-	-	-	-	-	TU10N9	49-215	18Ni9	-	-	-	-	-	Gr.7	A333	-	-
-	-	-	-	-	-	-	-	TU10N9	49-215	18Ni9	-	-	-	-	-	Gr.7	A334	-	-
12Ni14	1.5637	10216-4	10Ni14	1.5637	17173	503LT	3603	TU10N14	49-215	18Ni14	16222	-	-	-	-	Gr.3	A333	STPL450	G3460
12Ni14	1.5637	10253-2	10Ni14	1.5637	17173	503LT	3603	TU10N14	49-215	18Ni14	16222	-	-	-	-	Gr.3	A334	STBL450	G3464
X12Ni5	1.5680	10216-4	12Ni19	1.5680	17173	-	-	-	-	-	16527	-	-	-	-	-	-	-	-
X10Ni9	1.5682	10216-4	X8Ni9	1.5662	17173	509LT	3603	TUZ6N9	49-215	X12Ni09	17501	-	-	-	-	Gr.8	A333	-	-
X10Ni9	1.5682	1.5662	17173	509LT	3603	TUZ6N9	49-215	X12Ni09	17501	-	-	-	-	Gr.8	A334	-	-	-	-
<b>Ni-Mn steel</b>																			
11MnNi5-3	1.6212	10216-4	11MnNi5 3	1.6212	17173	-	-	-	-	-	-	-	-	-	-	-	-	-	-
13MnNi6-3	1.6217	10216-4	13MnNi6 3	1.6217	17173	-	-	-	-	-	-	-	-	-	-	-	-	-	-
15 NiCuMoNb5-6-4	1.6368	10216 - 2	(WB 36)	-	-	-	-	-	-	-	-	-	-	-	-	T / P 36	-	-	-

Steels for tubes for machine parts and chemical and thermal treatment, Type 26Mn5 according to EN

Table 52

EN			DIN			BS		NFA		UNI	ČSN, STN	GOST		PN-H		ASTM		JIS	
Steel	W.Nr.	Standard	Steel	W.Nr.	Standard	Steel	Standard	Steel	Standard	Steel	Steel	Steel	Standard	Steel	Standard	Steel	Standard	Steel	Standard
<b>Mn steel</b>																			
			21Mn4	1.0469	17115					20Mn4		20G	4543	20G	84019				
26Mn5	1.1161	10305-1				CFS7	6323-4					25G2	4543						
28Mn6	1.1170	10083-2	28Mn6	1.1170	17200	150M28	970	28Mn6	35-552	C28Mn	13141	30G2	4543	30G2	84030/04	1330	A519	SCMn1	G 4051
			16Mn9								13320					1527			
			36Mn4	1.0561	17204							35G	4543						
			36Mn5	1.1167	17204	150M36	970-3	35M5	35-552			35G2	4543	-	-	1335	A519	SMn438	G4052
			(36Mn7)								14240	35G2	4543						
38Mn6	1.1127	10297-1	36Mn6									40G2	4543						
			46Mn5	1.1128															
			46Mn7	1.0912							13250	45G2	4543						
<b>Mn-B steel</b>																			
20MnB5	1.5530	10083-3						20MB5	35-552										
30MnB5	1.5531	10083-3																	
38MnB5	1.5532	10083-3						38MB5	35-552										
<b>Mn-Cr steel</b>																			
16MnCr5	1.7131	10084	16MnCr5	1.7131	17210	590M17	970	16MC5	35-551	16MnCr5	14220	18ChG	4543			5115	A519	SCR415	G 4051
16MnCr5	1.7131	10297-1									14220								
20MnCr5	1.7147	10084	20MnCr5	1.7147	17210			20MC5	35-551	20MnCr5	14221	18ChG	4543	-	-	(5120)	A519		
<b>Mn-Cr-B steel</b>																			
16MnCrB5	1.7160	10084									14224	20ChGR	4543						
27MnCrB5-2	1.7182	10083-3																	
33MnCrB5-2	1.7185	10083-3																	
39MnCrB6-2	1.7189	10083-3																	
<b>Mn-Cr-Si steel</b>																			
(30MnCrSi4)	1.71XY										14331	30ChGSA	4543						
12MnCrSiMoTi	1.51XY										POD2001								
<b>Mn-Cr-V steel</b>																			
27MnCrV4	1.8162										15231								
<b>Mn-Si steel</b>																			
			10MnSi6 3	1.5125								09G2S	19281	-	-	-	-	-	-
(18MnSi6-3)												18G2S	5781						
(25MnSi6-3)												25G2S	5781						
			37MnSi5	1.5122				38MS5			13240	35GS	5781						
(20MnSi7)	1.51XY										Pre Trip								
<b>Mn-V steel</b>																			
20MnV6	1.5217	10294-1	20MnV6	1.5217		Gr.55	4360	20MV6	49-310	20MnV5	13220			18G2AV	84018	K 01907		STKM20A	G 3445
(E410)	1.0509	10305-1	(StE460)	1.8905	17124			S470M	49-312			-	-	-	-	K 12202		STKM20A	G 3445
<b>Mo steel</b>																			
26Mo2	1.5417	10305-1				CFS 9	6323-4												
20MoCr3	1.7320	10084																	
20MoCr4	1.7321	10084	20MoCr4	1.7321	17210														
<b>Cr-Ni steel</b>																			
16NiCr4	1.5714	10084								16CrNi4						3115	SAE		
15NiCr13	1.5752	10084	14NiCr14	1.5752		655M13	970	12NC15			16 420							SNC815	G 4052
			31NiCr14	1.5755				(30NC12)			16 440	30ChN3A	4543			3435	SAE		
10NiCr5-4	1.5805	10084	(10NiCr6)																
35NiCr6	1.5815	10083-3																	
17CrNi6-6	1.5918	10084	15CrNi6	1.5919	17210	(815M17)	970	16NC6	35-551	16CrNi4	16 321	(12ChN2)							
<b>Cr-Ni-Mo steel</b>																			
36CrNiMo4	1.6511	10083-3	36CrNiMo4	1.6511	17200	817M37	970-1			38NiCrMo4		40ChGNM	4543			9840	SAE		
36CrNiMo4	1.6511	10297-1																	
34CrNiMo6	1.6582	10083-3	34CrNiMo6	1.6582	17200	817M40	970			35NiCrMo6	16 343	36Ch2N2MA	4543						
30CrNiMo8	1.6580	10083-3	30CrNiMo8	1.6580	17200	823M30	970	30CND8	35-556	30NiCrMo8	16 430								
30CrNiMo8	1.6580	10297-1																	
18CrNiMo7-6	1.6587	10084	17CrNiMo6	1.6587	17210			18NCD6	35-551		16 326							SNCM431	G 4103
<b>Ni-Cr-Mo steel</b>																			
			16NiCrMo2							16NiCrMo2						8617	A519		
20NiCrMo2-2	1.6523	10084	21NiCrMo2	1.6523	17210	805M20	970	20NCD2	35-551	20NiCrMo2	16 125	20ChGNM	4543			8620	A519	SNCM220	G 4103
20NiCrMo2-2	1.6523	10297-1																	
41NiCrMo7-3-2	1.6563	10297-1	40NiCrMo73							40NiCrMo7									
17NiCrMo6-4	1.6566	10084	17NiCrMo5							17NiCrMo5									
14NiCrMo13-4	1.6657	10084	14NiCrMo134	1.6657		832M13	970	16NCD13								9310	A519		
36NiCrMo16	1.6773	10083-3	35NiCrMo16			835M30	970	38NCD16	35-571	34NiCrMo16									
39NiCrMo3	1.6510	10083-3																	
26NiCrMo8-5	1.6931		26NiCrMo85	1.6931							16 431								
18NiCrMo14-6			17NiCrMo14	1.3533	17230														
<b>Cr steel</b>																			
38Cr2	1.7003	10083-3	38Cr2	1.7003	17200			38C2	35-552	38Cr2									
46Cr2	1.7006	10083-3	46Cr2	1.7006	17200			42C2	35-552	45Cr2						5045	A519		
17Cr3	1.7016	10084	17Cr3	1.7016	17210	523M15	970-1	18C3			14120	15Ch	4543			(5015)	A519	SCR415	G 4104
			20Cr4	1.7027	17210														
28Cr4	1.7030	10084	28Cr4	1.7030	17200	530A30	970					30Ch	4543			5130	A519		

Steel 25CrMo4 is steel for machinery parts.

In EN 10216-2 is as boiler steel with reduced contents of P and S and guaranteed contents of Al.



EN			DIN			BS		NFA		UNI	ČSN,STN	GOST		PN-H		ASTM		JIS	
Steel	W.Nr.	Standard	Steel	W.Nr.	Standard	Steel	Standard	Steel	Standard	Steel	Steel	Steel	Standard	Steel	Standard	Steel	Standard	Steel	Standard
34Cr4	1.7033	10083-3	34Cr4	1.7033	17200	530A32	970-1	32C4	35-552	34Cr4	14141	35Ch	4543	-	-	5132	A519	SCR430	G 4052
37Cr4	1.7034	10083-3	37Cr4	1.7034	17200	530M36	970-1	38C4	35-553	38Cr4	14140	38Ch	4543			5135	A519	SCR435	G 4052
41Cr4	1.7035	10083-3	41Cr4	1.7035	17200	530A40	970-1	42C4	35-552	41Cr4	14 148	40Ch	4543	40H	84030	(5140)	A519	SCR440	G 4051
41Cr4	1.7035	10297-1	41Cr4	1.7035	17204					-	(14 151)	40Ch	4543	40H	84030	(5140)	A519	SCR440	G 4051
100Cr6	1.3505	683-17	100Cr6	1.3505	17230	535A99	970-1	100C6	35-565	100Cr6	14 109	'Ch15	801	LH 15	84041	52100		SUJ 2	G 4805
<b>Cr-Mo steel</b>																			
18CrMo4	1.7243	10084						18CD4	35-551	18CrMo4	15 124	20ChM	4543		-			SCM418	G 4052
25CrMo4	1.7218	10083-3	25CrMo4	1.7218	17200	708A25	970-1	25CD4	35-552	25CrMo4	15 130	30ChM	4543			4130	A519	SCM420	G 4105
25CrMo4	1.7218	10297-1	25CrMo4	1.7218	17204	CFS 10	6323-4	(27CD4)			15 130	30ChM	4543			4130	A519	SCM420	G 4105
30CrMo4	1.7216	10297-1								30CrMo4		30ChM	4543						
34CrMo4	1.7220	10083-3	34CrMo4	1.7220	17200	708A37	970-1	34CD4	35-552	34CrMo4	15 141	35ChM	4543			4135	A519	SCM435	G 4052
34CrMo4	1.7220	10297-1	34CrMo4	1.7220	17204														
42CrMo4	1.7225	10083-3	42CrMo4	1.7225	17200	708A40	970-1	42CD4	35-552	42CrMo4	15 142	38ChM	4543			4140	A519	SCM440	G 4052
42CrMo4	1.7225	10297-1	42CrMo4	1.7225	17204	CFS 11	6323-4									4142	A519	(SCM4)	G 4052
50CrMo4	1.7228	10083-3	50CrMo4	1.7228	17200			50CD4	35-552	50CrMo4						4150	A519	SCM445	G 4052
100CrMo7-3	1.3536	683-17	100CrMo7	1.3537	17230			100CD7	35-565	100CrMo7									
<b>Cr-Mn-Mo steel</b>																			
12CrMnMoV8-6	1.79XY										(POD 90)								
16CrMnMoV8-7	1.79XY		(BTR 110)								POD2000								
15CrMnMo9	1.79XY							15CMD9											
<b>Cr-V steel</b>																			
			42CrV6	1.7561							15 241								
			(30CrV9)	1.76XY							15 230								
51CrV4	1.8159	10083-3	50CrV4	1.8159	17200	735A50	970-1	50CV4	35-552	50CrV4	15 260	50ChGFA	14959			6150H	A519	SUP 10	G 4801
<b>Cr-Mo-V steel</b>																			
			15CrMoV5-9	1.8521	17211														
			15CrMoV5-10	1.7745															
			15CrMoV6	1.7734				15CDV6		15CrMoV6									
21CrMoV5-7	1.7709	10269	21CrMoV5 7	1.7709	17240			20CDV6	35-559	24CrMoV55	15 320	25Ch1M1F	20072						
30CrMoV9	1.7707	10250-3	30CrMoV9	1.7707	17200						15 330	30Ch3MF	4543						
31CrMoV9	1.8519	10085								31CrMoV9	15 330	30Ch3MF	4543						
										31CrMoV10									
32CrMoV12-9		10085	32CrMoV1210	1.7765				32CDV12											
40CrMoV13-9	1.8523	10085	39CrMoV139	1.8523	17211	897M39	970-1	40CDV13	35-590										
<b>Cr-Al-Mo steel</b>																			
			34CrAl6	1.8504							14 340	(38Ch2Ju)	4543						
32CrAlMo7-10	1.8505	10085																	
34CrAlMo5-10	1.8507	10085	34CrAlMo5	1.8507	17211			30CAD6.12		34CrAlMo7						K23510	A355		
41CrAlMo7-10	1.8509	10085	41CrAlMo7	1.8509	17211	905M39	970	40CAD6.12	35-552	41CrAlMo7	15 340	38Ch2MJuA	4543			K24065	A355	SACM645	G 4202
31CrMo12	1.8515	10085	31CrMo12	1.8515	17211	722M24	970	30CD12		32CrMo12									
34CrAlNi7-10	1.8550	10085	34CrAlNi7	1.8550	17211						(16 347)								

Comparison of fine-grained steel according to DIN and EN standards

Table 53

Series	DIN 17179		EN 10216 - 3	
	Identification	Grade	Identification	Grade
Basic	StE	255, 285, 355, 420, 460	P-N	355, 460
High temperature	WStE	255, 285, 355, 420, 460	P-NH	355, 460
Low temperature	TStE	255, 285, 355, 420, 460	P-NL1	275, 355, 460
Low temperature special	ESTe	255, 285, 355, 420, 460	P-NL2	275, 355, 460

Note: Steel grade condition Q are not given in comparison.

**Conversion table of inch and decimal values (1 inch = 25,4 mm)**

**Table 54**

x/64	Adjusted value	Decimal value	MM [mm]
1/64		.016	0,406
2/64	1/32	.031	0,787
3/64		.047	1,19
4/64	1/16	.063	1,60
5/64		.078	1,98
6/64	3/32	.094	2,38
7/64		.109	2,77
8/64	1/8	.125	3,18
9/64		.141	3,58
10/64	5/32	.156	3,96
11/64		.172	4,37
12/64	3/16	.188	4,77
13/64		.203	5,16
14/64	7/32	.219	5,56
15/64		.234	5,94
16/64	1/4	.250	6,35
17/64		.266	6,76
18/64	9/32	.281	7,14
19/64		.297	7,54
20/64	5/16	.313	7,95
21/64		.328	8,33
22/64	11/32	.344	8,73
23/64		.359	9,12
24/64	3/8	.375	9,52
25/64		.391	9,92
26/64	13/32	.406	10,32
27/64		.422	10,72
28/64	7/16	.438	11,11
29/64		.453	11,51
30/64	15/32	.469	11,91
31/64		.484	12,30
32/64	1/2	.500	12,70

x/64	Adjusted value	Decimal value	MM [mm]
33/64		.516	13,10
34/64	17/32	.531	13,49
35/64		.547	13,89
36/64	9/16	.563	14,29
37/64		.578	14,68
38/64	19/32	.594	15,08
39/64		.609	15,48
40/64	5/8	.625	15,88
41/64		.641	16,28
42/64	21/32	.656	16,66
43/64		.672	17,07
44/64	11/16	.688	17,47
45/64		.703	17,86
46/64	23/32	.719	18,26
47/64		.734	18,65
48/64	3/4	.750	19,05
49/64		.766	19,45
50/64	25/32	.781	19,84
51/64		.797	20,24
52/64	13/16	.813	20,65
53/64		.828	21,03
54/64	27/32	.844	21,43
55/64		.859	21,82
56/64	7/8	.875	22,22
57/64		.891	22,62
58/64	29/32	.906	23,02
59/64		.922	23,42
60/64	15/16	.938	23,82
61//64		.953	24,21
62/64	31/32	.969	24,61
63/64		.984	25,00
64/64	1/1	1.000	25,40

**Standard wire gauge for a wall thickness**

**Table 55**

Nr gauge	B.W.G.		S.W.G		Nearest 1/64 inch (BWG)
	inch	mm	inch	mm	
36	0.004	0,102	0.0076	0,193	-
35	0.005	0,127	0.0084	0,213	-
34	0.007	0,178	0.0092	0,234	-
33	0.008	0,203	0.0100	0,254	-
32	0.009	0,229	0.0108	0,274	-
31	0.010	0,254	0.0116	0,295	-
30	0.012	0,305	0.0124	0,315	-
29	0.013	0,330	0.0136	0,345	-
28	0.014	0,356	0.0148	0,376	-
27	0.016	0,406	0.0164	0,417	1/64
26	0.018	0,457	0.018	0,457	1/64
25	0.020	0,508	0.020	0,508	1/64
24	0.022	0,559	0.022	0,559	1/64
23	0.025	0,635	0.024	0,610	1/32
22	0.028	0,711	0.028	0,711	1/32
21	0.032	0,813	0.032	0,813	1/32
20	0.035	0,889	0.036	0,914	1/32
19	0.042	1,067	0.040	1,016	3/64
18	0.049	1,245	0.048	1,219	3/64
17	0.058	1,473	0.056	1,422	1/16
16	0.065	1,651	0.064	1,626	1/16
15	0.072	1,829	0.072	1,829	5/64

Nr gauge	B.W.G.		S.W.G		Nearest 1/64 inch (BWG)
	inch	mm	inch	mm	
14	0.083	2,108	0.080	2,032	5/64
13	0.095	2,413	0.092	2,337	3/32
12	0.109	2,769	0.104	2,642	7/64
11	0.120	3,048	0.116	2,946	1/8
10	0.134	3,404	0.128	3,251	9/64
9	0.148	3,759	0.144	3,658	9/64
8	0.165	4,191	0.160	4,064	11/64
7	0.180	4,572	0.176	4,470	3/16
6	0.203	5,156	0.192	4,877	13/64
5	0.220	5,588	0.212	5,385	7/32
4	0.238	6,045	0.232	5,893	15/64
3	0.259	6,579	0.252	6,401	17/64
2	0.284	7,214	0.276	7,010	9/32
1	0.300	7,620	0.300	7,620	19/64
0	0.340	8,636	0.324	8,230	11/32
2/0	0.380	9,652	0.348	8,839	3/8
3/0	0.425	10,80	0.372	9,449	27/64
4/0	0.454	11,53	0.400	10,16	29/64
5/0	-	-	0.432	10,97	-
6/0	-	-	0.464	11,78	-
7/0	-	-	0.500	12,70	-

**Comparison of tensile strength and hardness  
of Vickers hardness, Brinell hardness, Rockwell hardness and Tensile strength**

**Table 56**

Tensile strength N/mm <sup>2</sup>	Vickers HV 10	Hardness		
		Brinell HB	Rockwell HRB	Rockwell HRC
255	80	76,0		
270	85	80,7	41,0	
285	90	85,5	48,0	
305	95	90,2	52,0	
320	100	95,0	56,2	
335	105	99,8		
350	110	105	62,3	
370	115	109		
385	120	114	66,7	
400	125	119		
415	130	124	71,2	
430	135	128		
450	140	133	75,0	
465	145	138		
480	150	143	78,7	
495	155	147		
510	160	152	81,7	
530	165	156		
545	170	162	85,0	
560	175	166		
575	180	171	87,1	
595	185	176		
610	190	181	89,5	
625	195	185		
640	200	190	91,5	
660	205	195	92,5	
675	210	199	93,5	
690	215	204	94,0	
705	220	209	95,0	
720	225	214	96,0	
740	230	219	96,7	
755	235	223		
770	240	228	98,1	20,3
785	245	233		21,3
800	250	238	99,5	22,2
820	255	242		23,1
835	260	247	(101)	24,0
850	265	252		24,8
865	270	257	(102)	25,6
880	275	261		26,4
900	280	266	(104)	27,1
915	285	271		27,8
930	290	276	(105)	28,5
950	295	280		29,2
965	300	285		29,8
995	310	295		31,0
1030	320	304		32,2
1060	330	314		33,3

Tensile strength N/mm <sup>2</sup>	Vickers HV 10	Hardness		
		Brinell HB	Rockwell HRB	Rockwell HRC
1095	340	323		34,4
1125	350	333		35,5
1155	360	342		36,6
1190	370	352		37,7
1220	380	361		38,8
1255	390	371		39,8
1290	400	380		40,8
1320	410	390		41,8
1350	420	399		42,7
1385	430	409		43,6
1420	440	418		44,5
1455	450	428		45,3
1485	460	437		46,1
1520	470	447		46,9
1555	480	(456)		47,7
1595	490	(466)		48,4
1630	500	(475)		49,1
1665	510	(485)		49,8
1700	520	(494)		50,5
1740	530	(504)		51,1
1775	540	(513)		51,7
1810	550	(523)		52,3
1845	560	(532)		53,0
1880	570	(542)		53,6
1920	580	(551)		54,1
1955	590	(561)		54,7
1995	600	(570)		55,2
2030	610	(580)		55,7
2070	620	(589)		56,3
2105	630	(599)		56,8
2145	640	(608)		57,3
2180	650	(618)		57,8
	660			58,3
	670			58,8
	680			59,2
	690			59,7
	700			60,1
	720			61,0
	740			61,8
	760			62,5
	780			63,3
	800			64,0
	820			64,7
	840			65,3
	860			65,9
	880			66,4
	900			67,0
	920			67,5
	940			68,0

Values from standards DIN 50150, EN ISO 18265, ISO/TR 10108, ASTM E 140



Table 57

Designation system for steels - EN 10027-2				
<p><b>1 . XX XX(XX)</b></p> <p>Sequential number (digits in brackets are for possible future use)</p> <p>Steel group number</p> <p>Material group number 1 = Steel</p>				
Steel groups		Steel group number	Characteristic	
Non-alloy steels	B	Base steels	00 or 90	base steels
	Q	Quality steels	01 through 06 or 91 through 96	quality steels are divided into groups according to the maximum strength Rm and the average carbon content
			07 or 97	free-cutting steel
	S	Special steels	10	steels with special physical properties
11, 12, 13			structural, pressure and engineering steels	
15, 16, 17, 18			tool steels	
Alloy steels	QS	Quality steels	08, 09 or 98, 99	steels with special physical properties and steels for other applications
	SS	Special steels	0 20 21, 22, 23 24 až 26 27 28	<b>tool steels</b> - alloyed Cr - alloyed Cr+Si, Mn, V, Mo - alloyed W+Cr, V - alloyed Ni - other
			32, 33 35 36, 37 38, 39	<b>miscellaneous steels</b> - high speed steels - bearing steels - materials with special magnetic properties - steels with special physical properties
			40, 41, 43, 44 45 46 47, 48 49	<b>stainless and heat resisting steels</b> - stainless steel sorted according to the content of Ni - stainless steel with special additions - chemical resistant and high temp Ni alloys - heat resistant steels - material with elevated temperature properties
			50 až 53 54 55 56 57, 58, 59, 60 62, 63 65, 66, 67, 68, 69 70 71 72, 73 75, 76, 77 79, 80, 81, 82, 84 85 87 88, 89	<b>structural, pressure vessel and engineering steels</b> - alloyed Mn+Si, Cu, Cr, V, Ti - alloyed Mo, Nb, Ti, V, W - alloyed B, Mn-B - alloyed Ni - alloyed Cr-Ni - alloyed Ni and other elements Si, Mn, Cu, Mo, Mn, V - alloyed Cr - Ni - Mo and other elements - alloyed Cr a Cr-B - alloyed Cr+Si, Mn, B - alloyed Cr-Mo - alloyed Cr+V, Mo - alloyed Cr+Si, Mn, Mo, V, Ti, W - nitriding steels - steels not for treatment by user - high strength weldable steels not for heat treatment by user

## Contacts

**ŽELEZIARNE PODBREZOVÁ A.S.**  
Kolkáreň 35, 976 81 Podbrezová  
Slovak Republic  
+421/48/645 1111  
www.zelpo.sk, www.steel tubes.sk  
admin@zelpo.sk, marketing@zelpo.sk

### Marketing

+421/48/645 3014, 3010

### Sales

• Sales of cold-drawn tubes:

+421/48/6453041, 6453045, 6453034

• Sales of hot-finished tubes:

+421/48/6453041, 6453045, 6453034

• Sales of elbows and reducers:

+421/48/6453041, 6453045, 6453034

• Sales of tube semiproducts:

+421/48/6453076

• Sales of steel blooms:

+421/48/6453041, 6453045, 6453034

• fax:

+421/48/645 3032, 6453042, 6453072

### Commercial representatives:

#### PIPEX Italia S.p.A.

Via Paleocapa 10, 28041 Arona (Novara), Italia  
tel.: +39/0322/235511  
fax: +39/0322/44688  
e-mail: info@pipex.it, www.pipex.it

#### Pipex Deutschland GmbH,

Freseniusstrasse 17, 81247 Munich, Germany  
tel: 0049 (0)89 8110074  
fax: 0049 (0)89 8110233  
e-mail: info@pipex-deutschland.de, www.pipex-deutschland.de

#### ŽP TRADE Bohemia a.s.

Ztracená 272, 161 00 Praha 6, Czech Republic  
tel.: +420/235 301 190, 235 300748  
fax: +420/235300748  
e-mail: info@zptrade.cz, www.zptrade.cz

#### SLOVRUR Sp. z o.o.

ul. Brandwicka 138, 37-464 Stalowa Wola, Poland  
tel.: +48/15/844 8045-6, 8448051, 8448095  
fax: +48/15/8420234  
e-mail: dz.handlowy@slovrur.pl, www.slovrur.pl

#### TRANSFORMACIONES METALÚRGICAS, S.A.U.

Calle Joan Draper i Fossas, 30  
08350 Arenys de Mar, Barcelona, Spain  
tel: +34 93 7549200, fax: +34 93 7523847  
e-mail: transmesa@transmesa.com  
www.transmesa.com







**STEEL TUBE AND PIPE HANDBOOK**  
13<sup>TH</sup> EDITION, MARCH 2016

PUBLISHED BY:  
ŽELEZIARNE PODBREZOVÁ a.s.  
KOLKÁREŇ 35  
976 81 PODBREZOVÁ  
SLOVAK REPUBLIC

TEL: +421 48 6451111  
FAX: +421 48 6453032  
ADMIN@ZELPO.SK

[WWW.STEELTUBE.SK](http://WWW.STEELTUBE.SK) | [WWW.STAHL-ROHRE.EU](http://WWW.STAHL-ROHRE.EU) | [WWW.TUBESDEACERO.EU](http://WWW.TUBESDEACERO.EU) | [WWW.OCELOVERURY.SK](http://WWW.OCELOVERURY.SK)

This document contains confidential information intended for a specific individual and purpose, and is protected by law.  
You are hereby notified that any disclosure, copying, or distribution of this document is strictly prohibited.

